

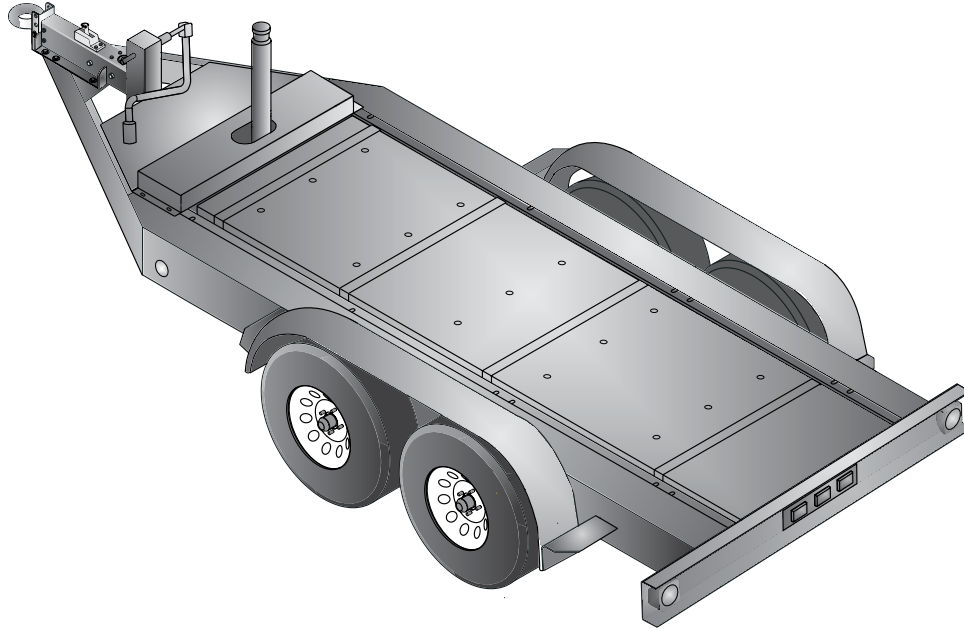

TRLR220XF

MQ POWER Tandem Axle Trailer



TRLR220XF Technical Data

Gross Vehicle Weight Rating (GVWR) — 13,500 lbs. (6,124 kg)	Tire Size — ST235/80R16 LR-E
Gross Axle Weight Rating (GAWR) — 7,000 lbs./3,175 kg (ea.)	Wheel Bolt Pattern — 8 Lug
Actuator Rating — 20,000 (9.072 kg)	Tire Load Rating — 3,500 lbs/1,588 kg (ea.)
Coupler Rating — See coupler options on back page.	Dimensions (LxWxH) — See back page

STANDARD TRAILER EQUIPMENT

- Fits MQ Power Generator Model DCA220SSJU4F
- Tandem-axle Design with Leaf Type Suspension
- H.D. Welded Steel Frame Construction
- Structural Channel for Generator Mounting and Support
- Integral Fuel Cell; Single-wall Steel Design; 300-gallon/1,136-liter Capacity; UN31A Certified
- Replaceable, Bolt-on Hydraulic Brake Actuator
- Surge Hydraulic-actuated Drum Brakes (all axles)
- Hydraulic Uni-servo Drum Brakes with Free-backing Plates - 12-inch Cluster
- D.O.T. Steel Brake Lines, Brass Tees and Rubber Hydraulic Brake Hoses
- 4-hole Channel Allows 3-position, Adjustable Coupler Height; 4-inches O/A
- Heavy-duty, Tongue Mounted, Drop-leg Jack (rated 10,000 lbs/4,536 kg lift)
- Replaceable, Bolt-on Steel Fenders
- High-gloss Enamel Coated Frame, Channel, Actuator and Fenders
- D.O.T. Approved Tail Lamps, Stop Lamps, Turn Signal Lamps, Side Marker Lamps
- Weatherproof, Rubber Armored, 3-piece Trailer Light Wiring Harness



TRLR220XF

MQ POWER Tandem Axle Trailer

OPTIONAL TRAILER EQUIPMENT

- Bolt-on Electric Brake Coupler Plate with Electric-actuated Drum Brakes (all axles)
- Electric Breakaway Safety Device (electric-actuated brakes)
- Adjustable 2 5/16-inch Ball Coupler
- Adjustable 3-inch Pintle-eye Coupler
- Rear Stabilizer Stands
- Tongue Mounted Utility Storage Box
- Anti-Theft Wheel Lock
- Spare Tire with Locking Mount

Coupler Options

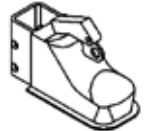
3" Pintle Eye 25,000 lbs. #EE36264	
2-5/16" Ball Coupler 14,000 lbs. #EE43253	

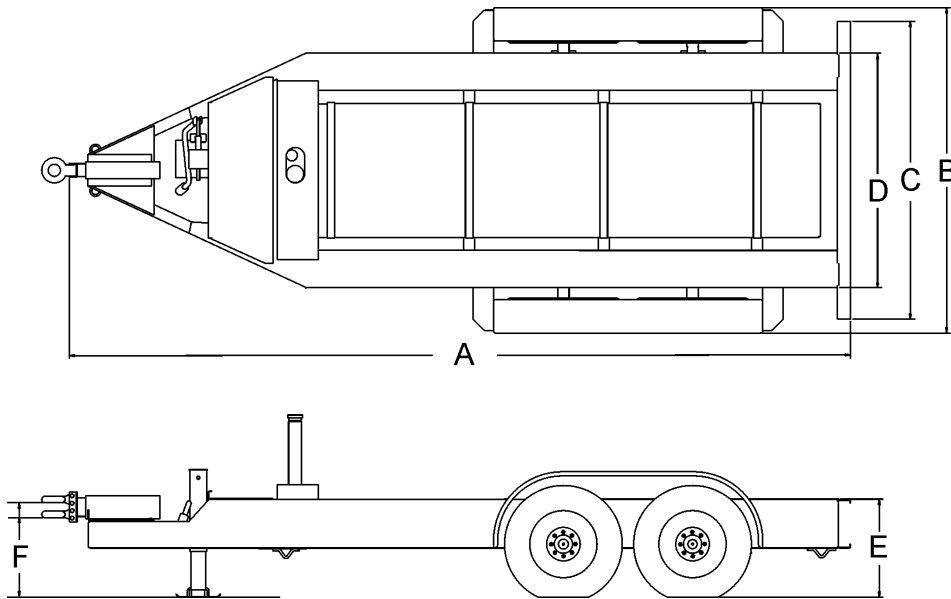

Trailer Dimensions						
A	B	C	D	E	F	
					MIN	MAX
209 in (5,309 mm)	87.4 in (2,220 mm)	80 in (2,032 mm)	63 in (1,600 mm)	26.4 in (671 mm)	21.4 in (544 mm)	25.4 in (645 mm)

Trailer Weight	
Without Fuel	With Fuel
3,390 lbs. (1,539 kg)*	5,520 lbs. (2,506 kg)*

**Weight is approximate*

Your MultiQuip dealer is:

