

Hydraulic
Generator
8 kW 60 Hz



Commercial GenSet

- Onan Custom Engineered Hydraulic Generator System
- High Motor Starting Capability
- Meets NFPA 120° F (48° C) Ambient* Standard
- Single Side Serviceability
- 100% Stainless Steel Housing/Multiple Air Inlets (4)
- Four-Point Vibration Isolated Mounting System
- Standard Hydraulic Circuit Eliminates the Need for Soft Start Accessory
- Hydraulic Circuit Design Prevents Overspeed
- Five Year, 1000 Hour Limited Warranty

Models and Ratings

<u>Model</u>	<u>Shaft</u>	<u>Hz</u>	<u>Watts</u>	<u>Voltage</u>	<u>Amps</u>	<u>PF</u>	<u>Phase</u>	<u>Circuit Breaker</u>
8RBAA-3544#	Keyed	60	8000	120/240	66.6/33.3	1.0	1	OEM/Distributor Supplied
8RBAA-2654#	Keyed	60	8000	120/240	66.6/33.3	1.0	1	OEM/Distributor Supplied
8RBAA-2283#	Spline	60	8000	120/240	66.6/33.3	1.0	1	OEM/Distributor Supplied
8RBAA-4783+	Spline	60	8000	120/240	66.6/33.3	1.0	1	OEM/Distributor Supplied
8RBAA-4784+	Keyed	60	8000	120/240	66.6/33.3	1.0	1	OEM/Distributor Supplied

Code 61 adapter flange not required on any of these gensets.

All 60 Hz models operate at 3600 r/min.

Spec 3544, 2654, and 2283 have a 45 cc pump SAE B flange. Required pump speed 950-3200 r/min. (Spec 3544 has a ccw pump).

+ Spec 4783 and 4784 have a 74 cc pump SAE BB flange. Required pump speed 550-3000 r/min.

* Onan tested for operation with cooling air inlet temperature up to 120° F (48° C). Ambient is defined as the air temperature measured at the cooling air inlet to the set.

Weight, Size and Sound Level

- Total weight: 262 lb (119 kg); genset 179 lb (81 kg), pump/manifold 70 lb (32 kg), reservoir 13 lb (6 kg)
- Genset: Length 31.0 in (787 mm), Width 16.0 in (405 mm), Height 13.8 in (350 mm)
- Sound Level: 60 Hz, 70 dB(A) at 10 ft (3 m), before installation, full load (estimated)

Standard Features

Hydraulic Components:

- Variable displacement piston pump
- Gear motor drive
- Adjustable orifice for frequency control
- Solenoid valve on pump stops fluid flow when system is off
- Hydraulic oil heat exchanger

Generator Housing:

- Stainless steel
- Single side serviceability
- Multiple air inlet locations (4)
- Single side interface for all hook-ups
- Installs without removing housing
- Four-point vibration isolated mounting system

Generator Output:

- 120/240 single phase, 4-lead
- 10-foot power leads in non-metallic conduit
- Power switch control, both mechanical and electrical
- Stable frequency
- Circuit breakers (OEM/distributor supplied)
- Capped voltage regulator
- Factory load tested

Controls and Displays:

- Onan display by FRC with 15 ft harness; displays Hz, volt, amps, oil temperature and hours
- On/off switch for generator power and rotation
- Solid state voltage regulation

Reservoir:

- 3 gallon hydraulic tank with integral filter
- Filter with element condition indicator gauge, breather, and fill port
- Mounting tabs for universal mounting

Accessories:

- Side discharge duct kit (part # 541-0762 (Spec B), part # 541-0873 (Spec C))
- Extension harnesses (see Operation and Installation manual)

Basic Dimensions

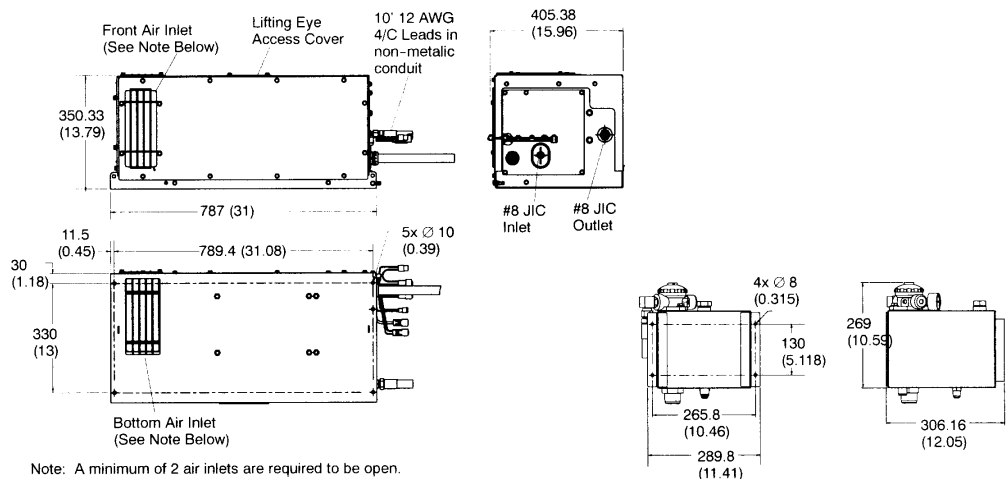

45cc pump

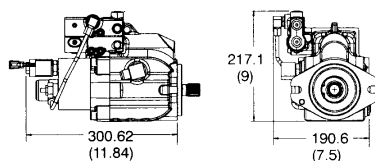

74cc pump

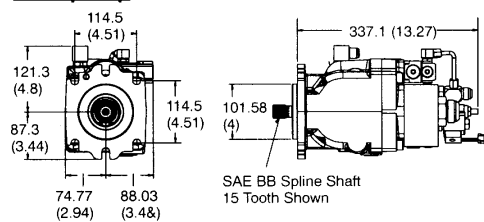

mm(in)

This outline drawing is provided for general reference only and is not intended for design or installation. For more information see Operation and Installation manual or obtain outline drawing 500-3452 (Spec A/B) or 500-3779 (Spec C) and wiring diagram from your Distributor/Dealer.

Alternator Detail

Design: Onan AC, 2-pole self-excited revolving field, permanently aligned to hydraulic motor by a splined shaft
Cooling: Direct drive blower wheel
Rotor: Laminated electrical steel assembly press-fitted to shaft, balanced; heavy insulated, class 200 copper wire windings, optimized air gap for improved wave form and motor starting

Stator: Laminated electrical steel assembly, skewed for improved waveform; heavy insulated, class 200 copper wire windings
DC brushes: Electrographic; long life
Bearing: Double-sealed pre-lubricated ball bearing
Exciter: Power Scan[®] regulator and bridge rectifier supply field current through slip rings

GenSet Detail

Voltage Regulation (steady state conditions):
 Random Voltage Variations
 Frequency Regulation (steady state conditions)
 Random Frequency Variation

No load - full load

±2%
 62.5 to 59 Hz (60.7 ±2.5%)

Constant load

±0.5%
 ±1.6% or
 ±1 Hz

Hydraulic Detail

Cooling:

- High efficiency forward-inclined blade, plug fan
- Pressurized box with distribution volutes for optimum air velocity across heat exchanger
- Welded blades, 4 brace rods and epoxy powder coated for best fan durability
- Heat exchanger sized relative to kW

Hydraulic Power:

- Operating flow and pressure range 8 Gal/min, 350-3000 psi
- Pump control is pressure compensated load sense system
- Solenoid operated shutoff valve

- Pump for specs 3544, 2654, 2283 - 45cc variable displacement
 - Required pump speed 950-3200 r/min maximum (overdrive PTO may be required)
 - SAE B flange 13 tooth 16/32 spline or 7/8" keyed shaft
- Pump for specs 4783, 4784 - 74cc variable displacement
 - Required pump speed 550-3000 r/min maximum
 - SAE BB flange 15 tooth 16/32 spline or 1-1/4" keyed shaft
- Both pumps require 23 HP from drive engine at full load
- Generator drive motor - fixed displacement gear
- Fluid Dexron III - 5 gallon total

Hydraulic Operational Schematic

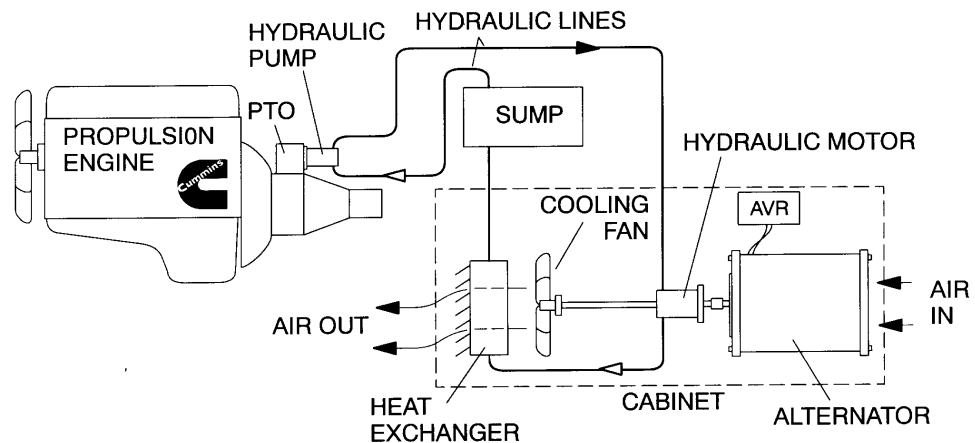

Warranty Policy

The ONAN limited warranty covers virtually everything except routine maintenance for the first five years that you own your generator set, or the first 1,000 hours of operation, whichever comes first. In addition, it includes a free 90-day adjustment policy, which provides that Onan will make minor adjustments to your new genset during the first three months you own it - free of charge!

Travel Time Repair Allowance: In addition to the 5-year, 1000-hour warranty, a travel time repair allowance of 2.5 hours and mileage cost up to 100 miles included for the first 2 years.

For complete Onan limited warranty details see your certified Onan Distributor/Dealer.

After Sale Support

EASY TO LOCATE CERTIFIED ONAN SERVICE AND PARTS DEALERS - Onan has the largest and best-trained worldwide certified Distributor/Dealer network in the industry, offering on-time parts and service, and installation assistance. Cummins Onan Distributor/Dealers stock and sell commonly used Onan GenSet maintenance parts, accessories and products, plus operator manuals and literature on current Onan GenSets. They can help you select and install the right genset or accessories on older models, or provide answers to questions on proper operation and maintenance procedures.

MANUALS - Operation and Installation manual is shipped with the genset. To obtain additional copies or other manuals for this model, see your Cummins Onan Distributor/Dealer and request the following part numbers: Operation and Installation Manual (943-0101), Parts Manual (943-0202), Service Manual (943-0501).

Standards and Testing

Tested at extremes of temperature -20° F to 120° F for starting and operation. Tested installed.

Tested with commercial loads.

Field Test Program.

This generator set was designed and manufactured in facilities certified to ISO 9001. CSA certified for CSA C22.2 Std 100 and Std 14 for operation up to 40° C only.



Contact your Distributor/Dealer for more information:



Cummins Power Generation
1400 73rd Avenue N.E.
Minneapolis, MN 55432 U.S.A.
phone: 1-800-888-ONAN or 763-574-5000
fax: 763-528-7242
e-mail: feedback@onan.com
WEB: www.onan.com

Onan is a brand of Cummins Power Generation. Cummins Power Generation is a subsidiary of Cummins Inc. Onan is a registered trademark of Cummins Inc.

WARNING: Backfeed to utility systems can cause electrocution or property damage. Do not connect to building electrical except through approved device and after building main breaker is opened.