

# OPERATION AND PARTS MANUAL



**MQ POWER®**

**WHISPERWATT™ SERIES  
MODEL DCA25SSIU4F  
60Hz GENERATOR  
(ISUZU 4LE2T DIESEL ENGINE)**



**PARTS LIST NO. M1871300104B**

Revision #0 (05/14/15)

To find the latest revision of this  
publication, visit our website at:  
[www.mqpower.com](http://www.mqpower.com)



**THIS MANUAL MUST ACCOMPANY THE EQUIPMENT AT ALL TIMES.**

 <b>WARNING</b> 
<b>CALIFORNIA — Proposition 65 Warning</b>
Diesel engine exhaust and some of its constituents are known to the State of California to cause cancer, birth defects and other reproductive harm.

## REPORTING SAFETY DEFECTS

---

If you believe that your vehicle has a defect that could cause a crash or could cause injury or death, you should immediately inform the National Highway Traffic Safety Administration (NHTSA) in addition to notifying Multiquip Inc. at 1-800-421-1244.

If NHTSA receives similar complaints, it may open an investigation, and if it finds that a safety defect exists in a group of vehicles, it may order a recall and remedy campaign. However, NHTSA cannot become involved in individual problems between you, your dealer, or Multiquip Inc.

To contact NHTSA, you may either call the Vehicle Safety Hotline toll-free at 1-888-327-4236 (TTY: 1-800-424-9153), go to <http://www.safercar.gov>, or write to:

Administrator  
NHTSA  
400 Seventh Street, SW.,  
Washington, DC 20590

You can also obtain information about motor vehicle safety from <http://www.safercar.gov>.

# TABLE OF CONTENTS

## DCA25SSIU4F 60 Hz Generator

Proposition 65 Warning .....	2
Reporting Safety Defects.....	3
Table Of Contents.....	4
Safety Information .....	6-11
Specifications .....	12
Dimensions.....	13
Installation .....	14-15
General Information.....	16
Major Components .....	17
Engine/Generator Control Panel.....	18-19
Output Terminal Panel Familiarization .....	20-22
Load Application .....	23
Generator Outputs.....	24-25
Gauge Reading .....	25
Output Terminal Panel Connections .....	26-27
Inspection/Setup.....	28-31
Generator Start-Up Procedure (Manual) .....	32-33
Generator Start-Up Procedure (Auto Mode).....	34
Generator Shut-Down Procedures .....	35
Maintenance .....	36-40
Trailer Maintenance .....	41-43
Trailer Guidelines.....	44-58
Troubleshooting Diagnostic Lamp .....	60
Troubleshooting Generator .....	61
Troubleshooting Engine .....	62-63
Generator Wiring Diagram.....	64
Engine Wiring Diagram.....	65
Controller Wiring Diagram .....	66
Battery Charger Wiring Diagram .....	68
Jacket Water Heater Wiring Diagram.....	69
Explanation Of Code In Remarks Column.....	70
Suggested Spare Parts .....	71

## Component Drawings

Generator Assembly.....	72-73
Control Box 1 Assembly .....	74-77
Control Box 2 Assembly .....	78-81
Engine And Radiator Assembly.....	82-85
Output Terminal Assembly.....	86-87
Battery Assembly.....	88-89
Muffler Assembly .....	90-91
Fuel Tank Assembly.....	92-93
Enclosure Assembly .....	94-97
Rubber Seals Assembly .....	98-99
Battery Charger Assembly (Option).....	100-101
Jacket Water Heater Assembly (Option).....	102-103
Nameplate And Decals Assembly .....	104-105
Terms And Conditions Of Sale — Parts .....	106

### NOTICE

Specifications and part numbers are subject to change without notice.



# SAFETY INFORMATION

Do not operate or service the equipment before reading the entire manual. Safety precautions should be followed at all times when operating this equipment. Failure to read and understand the safety messages and operating instructions could result in injury to yourself and others.

## SAFETY MESSAGES

The four safety messages shown below will inform you about potential hazards that could injure you or others. The safety messages specifically address the level of exposure to the operator and are preceded by one of four words: **DANGER**, **WARNING**, **CAUTION** or **NOTICE**.

## SAFETY SYMBOLS

 **DANGER**

Indicates a hazardous situation which, if not avoided, **WILL** result in **DEATH** or **SERIOUS INJURY**.

 **WARNING**

Indicates a hazardous situation which, if not avoided, **COULD** result in **DEATH** or **SERIOUS INJURY**.







 **CAUTION**

Indicates a hazardous situation which, if not avoided, **COULD** result in **MINOR** or **MODERATE INJURY**.

**NOTICE**

Addresses practices not related to personal injury.

Potential hazards associated with the operation of this equipment will be referenced with hazard symbols which may appear throughout this manual in conjunction with safety messages.

Symbol	Safety Hazard
	Lethal exhaust gas hazards
	Explosive fuel hazards
	Burn hazards
	Overspeed hazards
	Rotating parts hazards
	Pressurized fluid hazards
	Electric shock hazards

# SAFETY INFORMATION

## GENERAL SAFETY

### CAUTION

- **NEVER** operate this equipment without proper protective clothing, shatterproof glasses, respiratory protection, hearing protection, steel-toed boots and other protective devices required by the job or city and state regulations.



- **NEVER** operate this equipment when not feeling well due to fatigue, illness or when under medication.



- **NEVER** operate this equipment under the influence of drugs or alcohol.



- **ALWAYS** check the equipment for loosened threads or bolts before starting.
- **DO NOT** use the equipment for any purpose other than its intended purposes or applications.

### NOTICE

- This equipment should only be operated by trained and qualified personnel 18 years of age and older.
- Whenever necessary, replace nameplate, operation and safety decals when they become difficult read.
- Manufacturer does not assume responsibility for any accident due to equipment modifications. Unauthorized equipment modification will void all warranties.

- **NEVER** use accessories or attachments that are not recommended by MQ Power for this equipment. Damage to the equipment and/or injury to user may result.

- **ALWAYS** know the location of the nearest **fire extinguisher**.



- **ALWAYS** know the location of the nearest **first aid kit**.



- **ALWAYS** know the location of the nearest phone or **keep a phone on the job site**. Also, know the phone numbers of the nearest **ambulance, doctor and fire department**. This information will be invaluable in the case of an emergency.



## GENERATOR SAFETY

### DANGER

- **NEVER** operate the equipment in an explosive atmosphere or near combustible materials. An explosion or fire could result causing severe **bodily harm or even death**.



### WARNING

- **NEVER** disconnect any **emergency or safety devices**. These devices are intended for operator safety. Disconnection of these devices can cause severe injury, bodily harm or even death. Disconnection of any of these devices will void all warranties.

### CAUTION

- **NEVER** lubricate components or attempt service on a running machine.

### NOTICE

- **ALWAYS** ensure generator is on level ground before use.
- **ALWAYS** keep the machine in proper running condition.
- Fix damage to machine and replace any broken parts immediately.
- **ALWAYS** store equipment properly when it is not being used. Equipment should be stored in a clean, dry location out of the reach of children and unauthorized personnel

# SAFETY INFORMATION

## ENGINE SAFETY

### DANGER

- The engine fuel exhaust gases contain poisonous carbon monoxide. This gas is colorless and odorless, and can cause death if inhaled.
- The engine of this equipment requires an adequate free flow of cooling air. **NEVER** operate this equipment in any enclosed or narrow area where free flow of the air is restricted. If the air flow is restricted it will cause injury to people and property and serious damage to the equipment or engine.

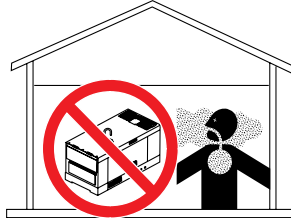

### WARNING

- **DO NOT** place hands or fingers inside engine compartment when engine is running.
- **NEVER** operate the engine with heat shields or guards removed.
- Keep fingers, hands hair and clothing away from all moving parts to prevent injury.
- **DO NOT** remove the radiator cap while the engine is hot. High pressure boiling water will gush out of the radiator and severely scald any persons in the general area of the generator.
- **DO NOT** remove the coolant drain plug while the engine is hot. Hot coolant will gush out of the coolant tank and severely scald any persons in the general area of the generator.



### CAUTION

- **NEVER** touch the hot exhaust manifold, muffler or cylinder. Allow these parts to cool before servicing equipment.



## NOTICE

- **NEVER** run engine without an air filter or with a dirty air filter. Severe engine damage may occur. Service air filter frequently to prevent engine malfunction.
- **NEVER** tamper with the factory settings of the engine or engine governor. Damage to the engine or equipment can result if operating in speed ranges above the maximum allowable.
- Wet stacking is a common problem with diesel engines which are operated for extended periods with light or no load applied. When a diesel engine operates without sufficient load (less than 40% of the rated output), it will not operate at its optimum temperature. This will allow unburned fuel to accumulate in the exhaust system, which can foul the fuel injectors, engine valves and exhaust system, including turbochargers, and reduce the operating performance.



In order for a diesel engine to operate at peak efficiency, it must be able to provide fuel and air in the proper ratio and at a high enough engine temperature for the engine to completely burn all of the fuel.

Wet stacking does not usually cause any permanent damage and can be alleviated if additional load is applied to relieve the condition. It can reduce the system performance and increase maintenance. Applying an increasing load over a period of time until the excess fuel is burned off and the system capacity is reached usually can repair the condition. This can take several hours to burn off the accumulated unburned fuel.

- State Health Safety Codes and Public Resources Codes specify that in certain locations, spark arresters must be used on internal combustion engines that use hydrocarbon fuels. A spark arrester is a device designed to prevent accidental discharge of sparks or flames from the engine exhaust. Spark arresters are qualified and rated by the United States Forest Service for this purpose. In order to comply with local laws regarding spark arresters, consult the engine distributor or the local Health and Safety Administrator.



# SAFETY INFORMATION

## FUEL SAFETY

### DANGER

- **DO NOT** start the engine near spilled fuel or combustible fluids. Diesel fuel is extremely flammable and its vapors can cause an explosion if ignited.
- **ALWAYS** refuel in a well-ventilated area, away from sparks and open flames.
- **ALWAYS** use extreme caution when working with **flammable** liquids.
- **DO NOT** fill the fuel tank while the engine is running or hot.
- **DO NOT** overfill tank, since spilled fuel could ignite if it comes into contact with hot engine parts or sparks from the ignition system.
- Store fuel in appropriate containers, in well-ventilated areas and away from sparks and flames.
- **NEVER** use fuel as a cleaning agent.
- **DO NOT** smoke around or near the equipment. Fire or explosion could result from fuel vapors or if fuel is spilled on a hot engine.



## TOWING SAFETY

### CAUTION

- Check with your local county or state safety towing regulations, in addition to meeting **Department of Transportation (DOT) Safety Towing Regulations**, before towing your generator.
- Refer to MQ Power trailer manual for additional safety information.
- In order to reduce the possibility of an accident while transporting the generator on public roads, **ALWAYS** make sure the trailer that supports the generator and the towing vehicle are mechanically sound and in good operating condition.
- **ALWAYS** shutdown engine before transporting



- Make sure the hitch and coupling of the towing vehicle are rated equal to, or greater than the trailer “gross vehicle weight rating.”
- **ALWAYS** inspect the hitch and coupling for wear. **NEVER** tow a trailer with defective hitches, couplings, chains, etc.
- Check the tire air pressure on both towing vehicle and trailer. **Trailer tires should be inflated to 50 psi cold.** Also check the tire tread wear on both vehicles.
- **ALWAYS** make sure the trailer is equipped with a **safety chain**.
- **ALWAYS** properly attach trailer’s safety chains to towing vehicle.
- **ALWAYS** make sure the vehicle and trailer directional, backup, brake and trailer lights are connected and working properly.
- DOT Requirements include the following:
  - Connect and test electric brake operation.
  - Secure portable power cables in cable tray with tie wraps.
- The maximum speed for highway towing is **55 MPH** unless posted otherwise. Recommended off-road towing is not to exceed **15 MPH** or less depending on type of terrain.
- Avoid sudden stops and starts. This can cause skidding, or jack-knifing. Smooth, gradual starts and stops will improve towing.
- Avoid sharp turns to prevent rolling.
- Trailer should be adjusted to a level position at all times when towing.
- Raise and lock trailer wheel stand in up position when towing.
- Place **chock blocks** underneath wheel to prevent **rolling** while parked.
- Place **support blocks** underneath the trailer’s bumper to prevent **tipping** while parked.
- Use the trailer’s swivel jack to adjust the trailer height to a level position while parked.

# SAFETY INFORMATION

## ELECTRICAL SAFETY

### DANGER

- **DO NOT** touch output terminals during operation. Contact with output terminals during operation can cause **electrocution, electrical shock or burn.**



- The electrical voltage required to operate the generator can cause severe injury or even death through physical contact with live circuits. Turn generator and all circuit breakers **OFF** before performing maintenance on the generator or making contact with output terminals.

- **NEVER** insert any objects into the output receptacles during operation. This is extremely dangerous. The possibility exists of **electrical shock, electrocution or death.**



- Backfeed to a utility system can cause **electrocution** and/or property damage. **NEVER** connect the generator to a building's electrical system without a transfer switch or other approved device. All installations should be performed by a **licensed electrician** in accordance with all applicable laws and electrical codes. Failure to do so could result in electrical shock or burn, causing **serious injury or even death.**



## Power Cord/Cable Safety

### DANGER

- **NEVER** let power cords or cables **lay in water.**
- **NEVER stand in water** while AC power from the generator is being transferred to a load.
- **NEVER** use **damaged** or **worn** cables or cords when connecting equipment to generator. Inspect for cuts in the insulation.
- **NEVER** grab or touch a live power cord or cable with wet hands. The possibility exists of **electrical shock, electrocution or death.**

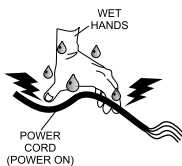

- Make sure power cables are securely connected to the generator's output receptacles. Incorrect connections may cause electrical shock and damage to the generator.

### NOTICE

- **ALWAYS** make certain that proper power or extension cord has been selected for the job. See Cable Selection Chart in this manual.

## Grounding Safety

### DANGER

- **ALWAYS** make sure that electrical circuits are properly grounded to a suitable earth ground (ground rod) per the National Electrical Code (NEC) and local codes before operating generator. **Severe injury or death by electrocution** can result from operating an ungrounded generator.

- **NEVER** use gas piping as an electrical ground.

## BATTERY SAFETY

### DANGER

- **DO NOT** drop the battery. There is a possibility that the battery will explode.
- **DO NOT** expose the battery to open flames, sparks, cigarettes, etc. The battery contains combustible gases and liquids. If these gases and liquids come into contact with a flame or spark, an explosion could occur.



### WARNING

- **ALWAYS** wear safety glasses when handling the battery to avoid eye irritation. The battery contains acids that can cause injury to the eyes and skin.
- Use well-insulated gloves when picking up the battery.
- **ALWAYS** keep the battery charged. If the battery is not charged, combustible gas will build up.
- **ALWAYS** recharge the battery in a well-ventilated environment to avoid the risk of a dangerous concentration of combustible gasses.



# SAFETY INFORMATION

- If the battery liquid (dilute sulfuric acid) comes into contact with **clothing or skin**, rinse skin or clothing immediately with plenty of water.
- If the battery liquid (dilute sulfuric acid) comes into contact with **eyes**, rinse eyes immediately with plenty of water and contact the nearest doctor or hospital to seek medical attention.

## CAUTION

- **ALWAYS** disconnect the **NEGATIVE battery terminal** before performing service on the generator.
- **ALWAYS** keep battery cables in good working condition. Repair or replace all worn cables.

## ENVIRONMENTAL SAFETY/DECOMMISSIONING

### NOTICE

Decommissioning is a controlled process used to safely retire a piece of equipment that is no longer serviceable. If the equipment poses an unacceptable and unrepairable safety risk due to wear or damage or is no longer cost effective to maintain (beyond life-cycle reliability) and is to be decommissioned (demolition and dismantlement), be sure to follow rules below.

- **DO NOT** pour waste or oil directly onto the ground, down a drain or into any water source.
- Contact your country's Department of Public Works or recycling agency in your area and arrange for proper disposal of any electrical components, waste or oil associated with this equipment.
- When the life cycle of this equipment is over, remove battery and bring to appropriate facility for lead reclamation. Use safety precautions when handling batteries that contain sulfuric acid.
- When the life cycle of this equipment is over, it is recommended that the trowel frame and all other metal parts be sent to a recycling center.



Metal recycling involves the collection of metal from discarded products and its transformation into raw materials to use in manufacturing a new product.

Recyclers and manufacturers alike promote the process of recycling metal. Using a metal recycling center promotes energy cost savings.

## EMISSIONS INFORMATION

### NOTICE

The diesel engine used in this equipment has been designed to reduce harmful levels of carbon monoxide (CO), hydrocarbons (HC) and nitrogen oxides (NOx) contained in diesel exhaust emissions.

This engine has been certified to meet US EPA Evaporative emissions requirements in the installed configuration.

Attempting to modify or make adjustments to the engine emission system by unauthorized personnel without proper training could damage the equipment or create an unsafe condition.

Additionally, modifying the fuel system may adversely affect evaporative emissions, resulting in fines or other penalties.

### Emission Control Label

The emission control label is an integral part of the emission system and is strictly controlled by regulations.

The label must remain with the engine for its entire life.

If a replacement emission label is needed, please contact your authorized engine distributor.

# SPECIFICATIONS

**Table 1. Generator Specifications**

<b>Model</b>	DCA25SSIU4F	
<b>Type</b>	Revolving field, self ventilated, open protected type synchronous generator	
<b>Armature Connection</b>	<b>Star with Neutral</b>	<b>Zigzag</b>
<b>Phase</b>	3Ø	3Ø
<b>Standby Output</b>	22.0 kW (27.5 kVA)	15.8 kW
<b>Prime Output</b>	20 kW (25 kVA)	14.4 kW
<b>3Ø Voltage (L-L/L-N) Voltage Selector Switch at 3Ø 240/139</b>	208Y/120, 220Y/127, 240Y/139	
<b>3Ø Voltage (L-L/L-N) Voltage Selector Switch at 3Ø 480/277</b>	416Y/240, 440Y/254, 480Y/277	
<b>1Ø Voltage (L-L/L-N) Voltage Selector Switch at 1Ø 240/120</b>	240/120	
<b>Power Factor</b>	0.8	1.0
<b>Frequency</b>	60 Hz	
<b>Speed</b>	1800 rpm	
<b>Aux. AC Power</b>	Single Phase, 60 Hz	
<b>Aux. Voltage/Output</b>	4.8 Kw (2.4 kW x 2)	
<b>Dry Weight</b>	1,797 lbs. (815 kg))	
<b>Wet Weight</b>	1,797 lbs. (815 kg)	

**Table 2. Engine Specifications**

<b>Model</b>	Isuzu 4LE2T	
<b>Type</b>	Water-cooled, direct injection, turbo-charged air cooled EGR	
<b>No. of Cylinders</b>	4 cylinders	
<b>Bore x Stroke</b>	3.35 in. x 3.78 in. (85 mm x 96 mm)	
<b>Displacement</b>	133 cu. in. (2.179 liter)	
<b>Rated Output</b>	33.5 HP at 1800 rpm	
<b>Starting</b>	Electric	
<b>Coolant Capacity</b>	2.3 gal. (8.8 liters) <sup>1</sup>	
<b>Lube Oil Capacity</b>	2.8 gal. (10.5 liters) <sup>2</sup>	
<b>Lubricating Type Oil</b>	API service class CJ-4 SAE or JASO DH-2	
<b>Fuel Type</b>	#2 Diesel Fuel (Ultra low sulfur diesel fuel only)	
<b>Fuel Leak Warning Capacity</b>	12.7 gal. (48 liters)	
<b>Fuel Tank Capacity</b>	41.7 gal. (158 liters)	
<b>Fuel Consumption</b>	1.62 gal. (6.12 L)/hr at <b>full load</b>	1.26 gal. (4.77 L)/hr at <b>3/4 load</b>
	.94 gal. (3.57 L)/hr at <b>1/2 load</b>	0.67 gal. (2.52 L)/hr at <b>1/4 load</b>
<b>Exhaust Gas After-Treatment System</b>	DOC	
<b>Battery</b>	27 (CCA 0°F 800A) X 1	

<sup>1</sup> Includes engine and radiator hoses

<sup>2</sup> Includes filters

# DIMENSIONS

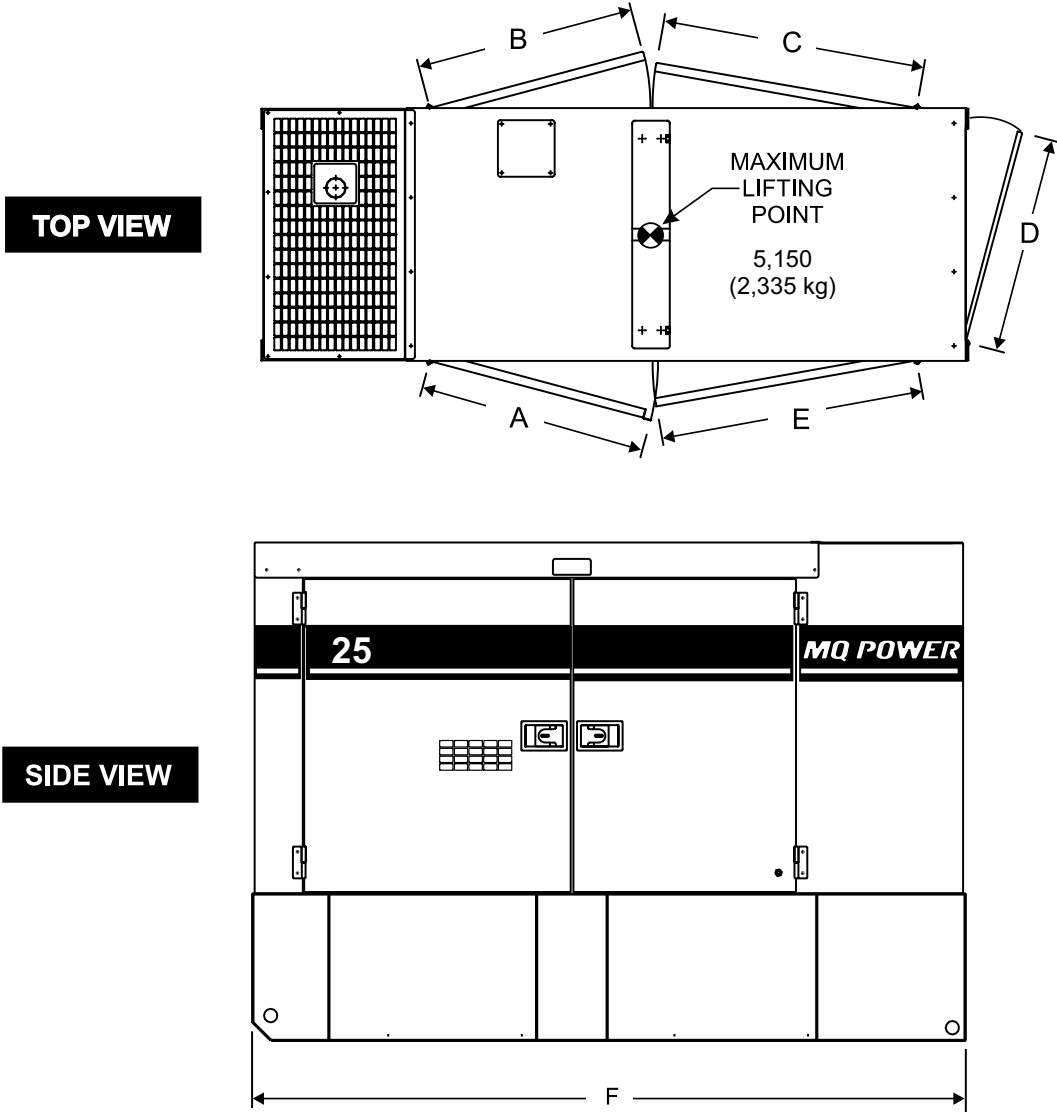

Figure 1. Dimensions

Table 3. Dimensions			
Reference Letter	Dimension in. (mm)	Reference Letter	Dimension in. (mm)
A	22.91 (582)	E	22.36 (568)
B	21.73 (552)	F	71.65 (1,820)
C	22.36 (568)	G	49.61 (1,260)
D	26.38 (670)	H	31.10 (790)

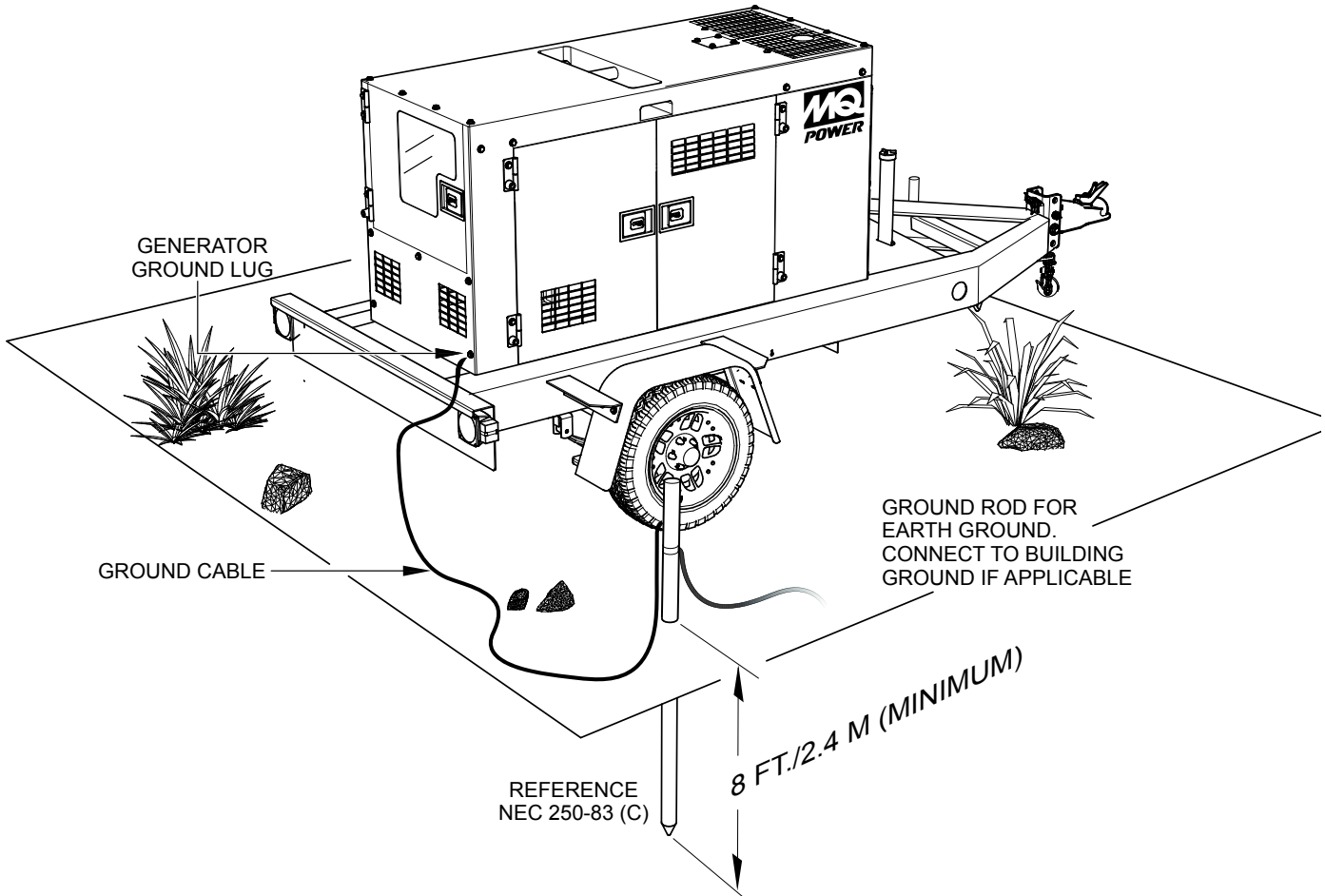

Figure 2. Typical Generator Grounding Application

## OUTDOOR INSTALLATION

Install the generator in a area that is free of debris, bystanders, and overhead obstructions. Make sure the generator is on secure level ground so that it cannot slide or shift around. Also install the generator in a manner so that the exhaust will not be discharged in the direction of nearby homes.

The installation site must be relatively free from moisture and dust. All electrical equipment should be protected from excessive moisture. Failure to do will result in deterioration of the insulation and will result in short circuits and grounding.

Foreign materials such as dust, sand, lint and abrasive materials have a tendency to cause excessive wear to engine and alternator parts.

### CAUTION

Pay close attention to ventilation when operating the generator inside tunnels and caves. The engine exhaust contains noxious elements. Engine exhaust must be routed to a ventilated area.

## INDOOR INSTALLATION

Exhaust gases from diesel engines are extremely poisonous. Whenever an engine is installed indoors the exhaust fumes must be vented to the outside. The engine should be installed at least two feet from any outside wall. Using an exhaust pipe which is too long or too small can cause excessive back pressure which will cause the engine to heat excessively and possibly burn the valves.

## MOUNTING

The generator must be mounted on a solid foundation (such as concrete) and set firmly on the foundation to isolate vibration of the generator when it is running. The generator must set at least 6 inches above the floor or grade level (in accordance to NFPA 110, Chapter 5-4.1). **DO NOT** remove the metal skids on the bottom of the generator. They are to resist damage to the bottom of the generator and to maintain alignment.

## GENERATOR GROUNDING

To guard against electrical shock and possible damage to the equipment, it is important to provide a good **EARTH** ground (Figure 2).

Article 250 (Grounding) of the National Electrical Code (NEC) provides guide lines for proper grounding and specifies that the cable ground shall be connected to the grounding system of the building as close to the point of cable entry as practical.

NEC articles 250-64(b) and 250-66 set the following grounding requirements:

1. Use one of the following wire types to connect the generator to earth ground.
  - a. Copper - 8 AWG (5.3 mm<sup>2</sup>)
  - b. Aluminum - 6 AWG (8.4 mm<sup>2</sup>)
2. When grounding the generator (Figure 2) connect the ground cable between the lock washer and the nut on the generator and tighten the nut fully. Connect the other end of the ground cable to earth ground.
3. NEC article 250-52(c) specifies that the earth ground rod should be buried a minimum of 8 ft. into the ground.

### NOTICE

When connecting the generator to any buildings electrical system **ALWAYS** consult with a licensed electrician.

### NOTICE

This generator has a permanent bonding conductor between the generator stator windings and the frame.

# GENERAL INFORMATION

## GENERATOR

This generator (Figure 3) is designed as a high quality portable (requires a trailer for transport) power source for telecom sites, lighting facilities, power tools, submersible pumps and other industrial and construction machinery.

## OPERATING PANEL

The “Operating Panel” is provided with the following:

- ECU Controller
- Gauge Unit Assembly
  - Oil Pressure Gauge
  - Water Temperature Gauge
  - Charging Voltmeter
  - Fuel Gauge
  - Tachometer
- Panel Light/Panel Light Switch
- Pre Heat Lamp
- Warning lamp (Diagnostic)
- Hour Meter
- Engine Speed Switch
- Auto Start/Stop Switch
- Fuel Leak Detected Alarm Lamp

## CONTROL PANEL

The “Control Panel” is provided with the following:

- Frequency Meter (Hz)
- AC Ammeter (Amps)
- AC Voltmeter (Volts)
- Ammeter Change-Over Switch
- Voltmeter Change-Over Switch
- Voltage Regulator
- 3-Pole, 60 amp Main Circuit Breaker
- “Control Box” (located behind Control Panel)
  - Automatic Voltage Regulator
  - Current Transformer
  - Over-Current Relay
  - Starter Relay

## OUTPUT TERMINAL PANEL

The “Output Terminal Panel” is provided with the following:

- Two 120/240V output receptacles (CS-6369), 50A
- Two auxiliary circuit breakers, 50A
- Two 120V output receptacles (GFCI), 20A
- Two GFCI circuit breakers, 20A
- Five output terminal lugs (3Ø power)
- Battery Charger (Option)
- Jacket Water Heater (Option)
- Low Coolant Switch (Option)

## OPEN DELTA EXCITATION SYSTEM

Each generator is equipped with the state of the art “Open-Delta” excitation system. The open delta system consist of an electrically independent winding wound among stationary windings of the AC output section.

There are four connections of the open delta A, B, C and D. During steady state loads, the power from the voltage regulator is supplied from the parallel connections of A to B, A to D, and C to D. These three phases of the voltage input to the voltage regulator are then rectified and are the excitation current for the exciter section.

When a heavy load, such as a motor starting or a short circuit occurs, the automatic voltage regulator (AVR) switches the configuration of the open delta to the series connection of B to C. This has the effect of adding the voltages of each phase to provide higher excitation to the exciter section and thus better voltage response during the application of heavy loads.

The connections of the AVR to the AC output windings are for sensing only. No power is required from these windings. The open-delta design provides virtually unlimited excitation current, offering maximum motor starting capabilities. The excitation does not have a “fixed ceiling” and responds according to the demands of the required load.

## ENGINE

This generator is powered by a 4 cylinder, 4-cycle water cooled, direct injection, turbocharged, air cooled and EGR Isuzu 4LE2T diesel engine. This engine is designed to meet every performance requirement for the generator. Reference Table 2 for engine specifications.

In keeping with MQ Power’s policy of constantly improving its products, the specifications quoted herein are subject to change without prior notice.

## ELECTRIC GOVERNOR SYSTEM

The electric governor system controls the RPMs of the engine. When the engine demand increases or decreases, the governor system regulates the frequency variation to  $\pm 0.25\%$ .

## EXTENSION CABLES

When electric power is to be provided to various tools or loads at some distance from the generator, extension cords are normally used. Cables should be sized to allow for distance in length and amperage so that the voltage drop between the generator and point of use (load) is held to a minimum. Use the cable selection chart (Table 6) as a guide for selecting proper extension cable size.



# MAJOR COMPONENTS

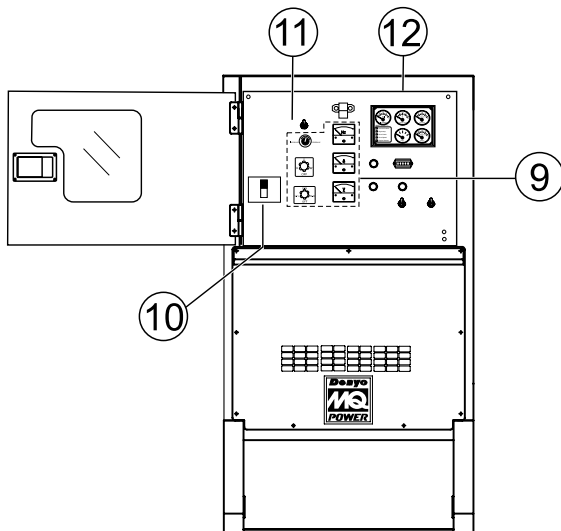
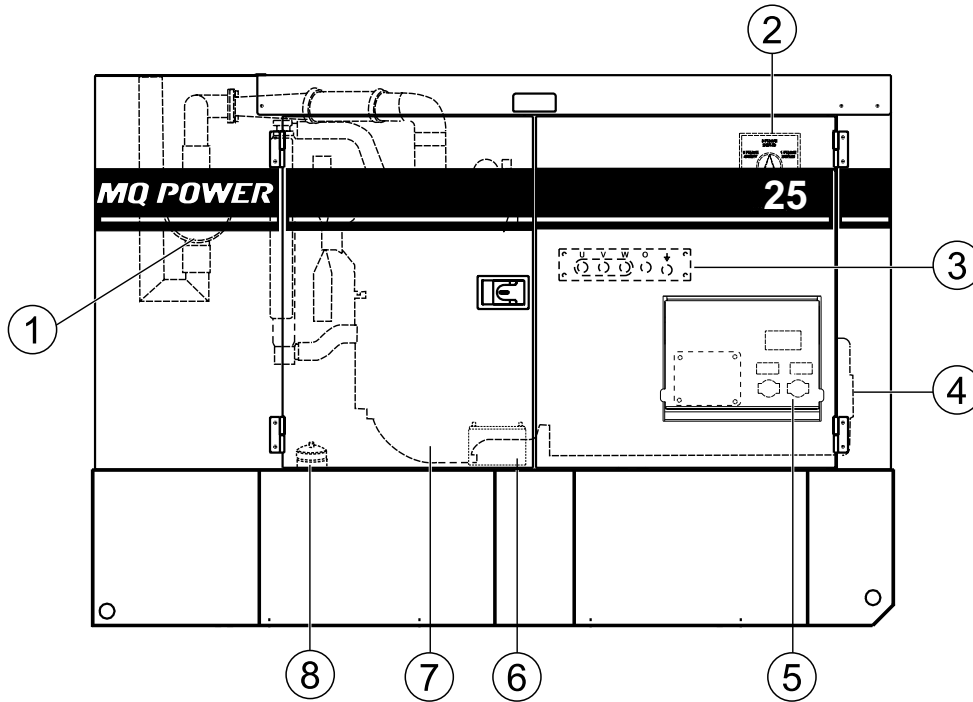
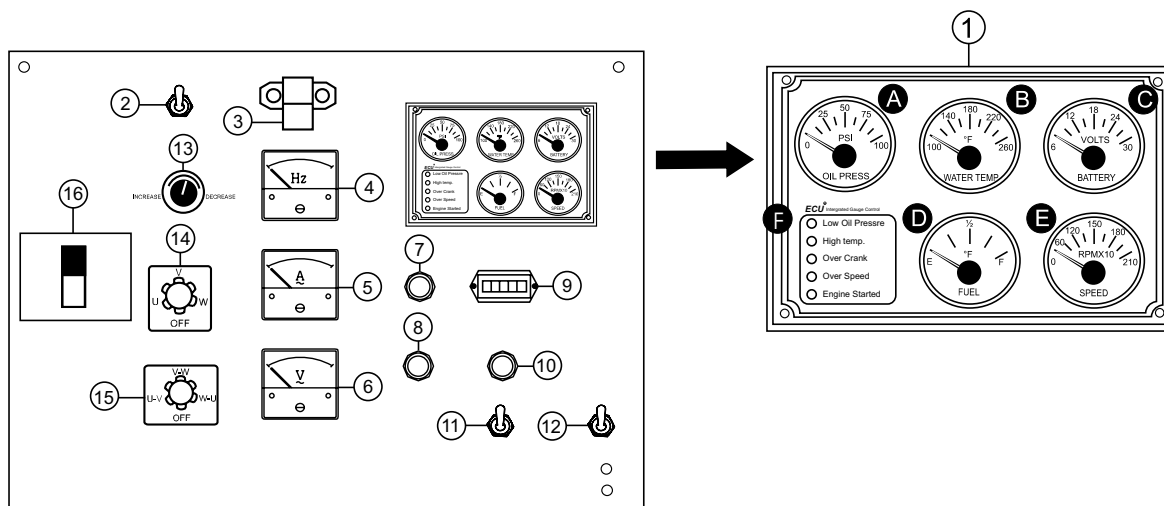

Figure 3. Major Components

Table 4. Generator Major Components	
ITEM NO.	DESCRIPTION
1	Muffler Assembly
2	Voltage Selector Switch Assembly
3	Output Terminal Assembly
4	Generator Assembly
5	Output Receptacles Assembly
6	Battery Assembly
7	Engine Assembly
8	Fuel Tank Assembly
9	Circuit Breaker Assembly
10	Auto Start/Stop Controller Assembly
11	Gauge Unit Assembly
12	Generator Control Panel Assembly

# ENGINE/GENERATOR CONTROL PANEL



**Figure 4. Engine/Generator Control Panel**

The definitions below describe the controls and functions of the Engine/Generator Control Panel (Figure 4).

1. **Gauge Unit Assembly** — This assembly houses the various engine monitoring gauges. These gauges indicate: oil pressure, water temperature, charging voltmeter, fuel and engine speed RPM (tachometer).

- A. **Oil Pressure Gauge** — During normal operation this gauge should read between 35 to 65 psi. (241~448 kPa). When starting the generator the oil pressure may read a little higher, but after the engine warms up the oil pressure should return to the correct pressure range.
- B. **Water Temperature Gauge** — During normal operation this gauge should read between 185° and 207°F (85°~97°C).
- C. **Charging Voltmeter Gauge** — During normal operation this gauge indicates minimum 14 VDC
- D. **Fuel Gauge** — Indicates amount of diesel fuel available.
- E. **Tachometer** — Indicates engine speed in RPM's for 60 Hz operation. This meter should indicate 1800 RPM's when the rated load is applied.

## F. Warning LEDs

- **Low Oil Pressure LED** — This LED will light when the engine oil pressure drops to 14.2 PSI. This condition will cause the engine to shut down.
  - **High Temperature LED** — This LED will light when the coolant temperature has reached 207°F (85°~97°C). This condition will cause the engine to shut down.
  - **Over Crank LED** — This LED will light when the engine has attempted to start 3 times and failed. The intervals between the 3 start cycles is approximately 10 seconds.
  - **Over Speed LED** — This LED will light when the engine is running at an unsafe speed. This condition will cause the engine to shut down.
  - **Engine Started LED** — This LED will light when the engine has started and is operating correctly.
2. **Panel Light Switch** — When activated will turn on control panel light.
3. **Panel Light** — For operation at night, panel light illuminates control panel for ease of reading meters and gauges. Make sure panel light switch is in the OFF position when light is not in use.

## ENGINE/GENERATOR CONTROL PANEL

---

4. **Frequency Meter** — Indicates the output frequency in hertz (Hz). Normally 60 Hz
5. **AC Ammeter** — Indicates the amount of current the load is drawing from the generator per leg selected by the ammeter phase-selector switch.
6. **AC Voltmeter** — Indicates the output voltage present at the **U,V, and W Output Terminal Lugs**.
7. **Fuel Leak Detected Alarm Lamp** — This lamp when ON indicates that fluids in the containment area have reach a high level.
8. **Warning Lamp** — This lamp turns ON when an engine fault/failure has occurred, Reference **Troubleshooting Diagnostic Lamp** section in this manual for fault code details.
9. **Hour Meter** — Indicates the operational hours of the generator.
10. **Pre-Heat Lamp** — When the Auto Start/Stop Switch is placed in the manual position, this lamp will illuminate to indicate preheating of the engine glow plugs. When the lamp turns off, this indicates that the preheat cycle is complete and the engine can be started.
11. **Auto Start-Stop Switch** — This switch selects either manual or automatic operation . Center position is OFF (reset).
12. **Engine Speed Switch** — This switch controls the speed of the engine low or high.
13. **Voltage Regulator Control** — Allows  $\pm 15\%$  manual adjustment of the generator's output voltage.
14. **Ammeter Change-Over Switch** — This switch allows the AC ammeter to indicate the current flowing to the load connected to any phase of the output terminals, or to be switched off. This switch does not effect the generator output in any fashion, it is for current reading only.
15. **Voltmeter Change-Over Switch** — This switch allows the AC voltmeter to indicate phase to phase voltage between any two phases of the output terminals or to be switched off.
16. **Main Circuit Breaker** — This three-pole, 60 amp main breaker is provided to protect the **U,V, and W Output Terminal Lugs** from overload.

# OUTPUT TERMINAL PANEL FAMILIARIZATION

## OUTPUT TERMINAL PANEL

The Output Terminal Panel (Figure 5) shown below is located on the right-hand side (left from control panel) of the generator. Lift up on the cover to gain access to receptacles and terminal lugs.

### NOTICE

Terminal legs "O" and "Ground" are considered bonded grounds

## OUTPUT TERMINAL FAMILIARIZATION

The "Output Terminal Panel" (Figure 5) is provided with the following:

- Two 240/139V output receptacles @ 50 amps
- Two Aux. Circuit Breakers @ 50 amps
- Two 120V GFCI receptacles @ 20 amp
- Two GFCI Circuit Breakers @ 20 amps
- Five Output Terminal Lugs ( U, V, W, O, Ground)

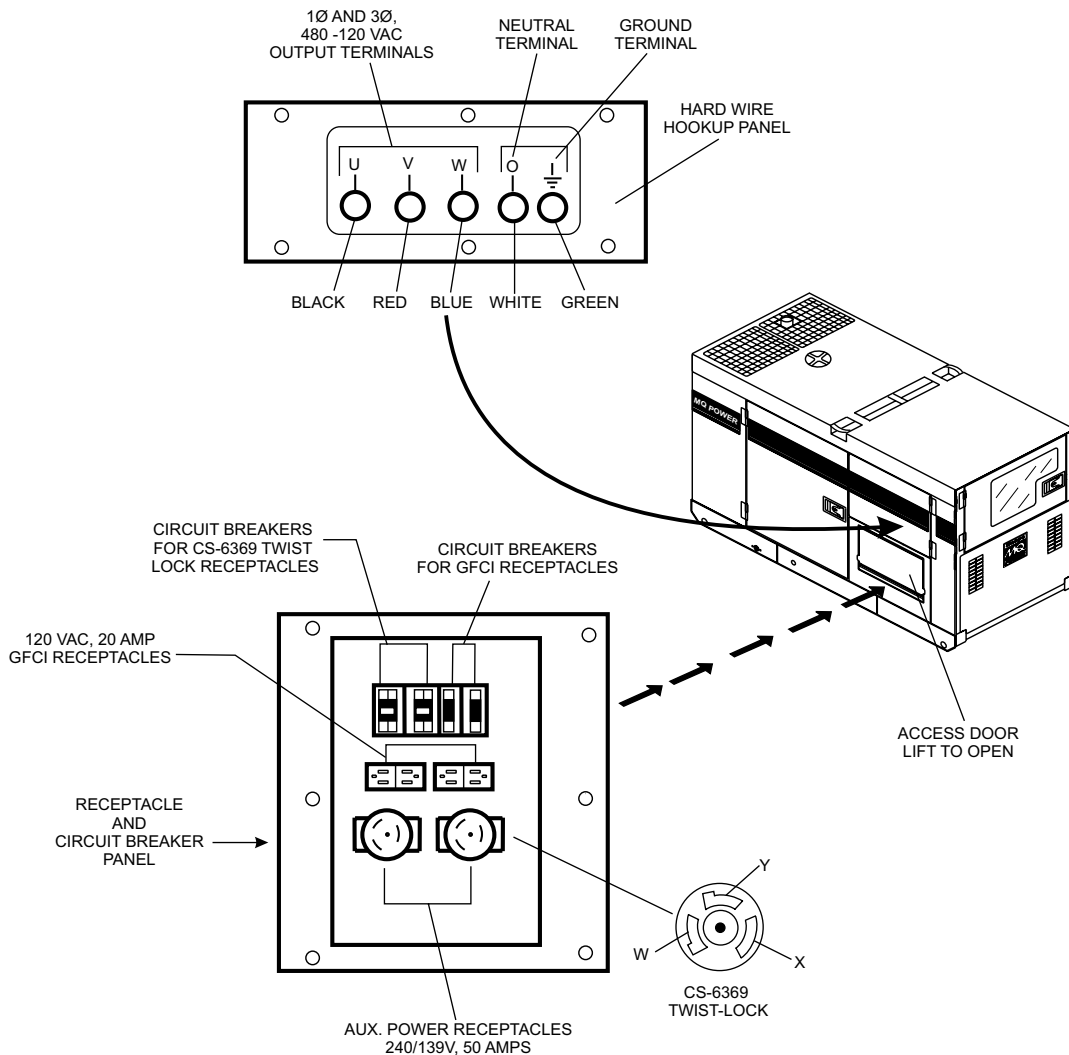

Figure 5. Output Terminal Panel

# OUTPUT TERMINAL PANEL FAMILIARIZATION

## 120 VAC GFCI Receptacles

There are two 120 VAC, 20 amp GFCI (Duplex Nema 5-20R) receptacles provided on the output terminal panel. These receptacles can be accessed in any **voltage change-over board** configuration. Each receptacle is protected by a 20 amp circuit breaker. These breakers are located directly above the GFCI receptacles. Remember the load output (current) of both GFCI receptacles is dependent on the load requirements of the U, V, and W output terminal lugs.

Pressing the **reset** button resets the GFCI receptacle after being tripped. Pressing the **test button** (See Figure 6) in the center of the receptacle will check the GFCI function. Both receptacles should be tested at least once a month.

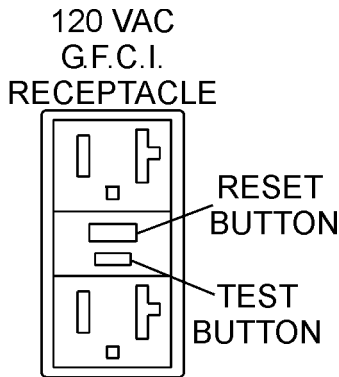

Figure 6. G.F.C.I. Receptacle

## Twist Lock Dual Voltage 120/240 VAC Receptacles

There are two 240/139V, 50 amp auxiliary twist-lock (CS-6369) receptacles (Figure 7) provided on the output terminal panel. These receptacles can **only** be accessed when the voltage selector switch is placed in the **single-phase 240/120** position.

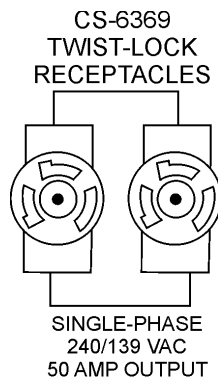

Figure 7. 240/139V Twist-Lock Auxiliary Receptacles

Each auxiliary receptacle is protected by a 50 amp circuit breaker. These breakers are located directly above the GFCI receptacles. Remember the load output (current) on both receptacles is dependent on the load requirements of the **output terminal lugs**.

Turn the **voltage regulator control knob** (Figure 8) on the control panel to obtain the desired voltage. Turning the knob clockwise will **increase** the voltage, turning the knob counter-clockwise will **decrease** the voltage.

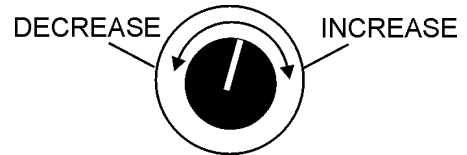

Figure 8. Voltage Regulator Control Knob

## Removing the Plastic Face Plate (Hard Wire Hookup Panel)

The **Output Terminal Lugs** are protected by a plastic face plate cover (Figure 9). Un-screw the securing bolts and lift the plastic terminal cover to gain access to the terminal enclosure.

After the load wires have been securely attached to the terminal lugs, reinstall the plastic face plate.

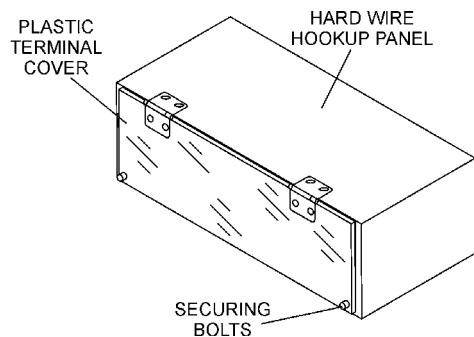

Figure 9. Plastic Face Plate (Output Terminal Lugs)

# OUTPUT TERMINAL PANEL FAMILIARIZATION

## Connecting Loads

Loads can be connected to the generator by various methods, output terminal lugs, camlocks or the convenience receptacles (Figure 10). Make sure to read the operation manual before attempting to connect a load to the generator.

To protect the output terminals from overload, a 3-pole, 60A **main** circuit breaker is provided. Make sure to switch **ALL** circuit breakers to the **OFF** position prior to starting the engine.

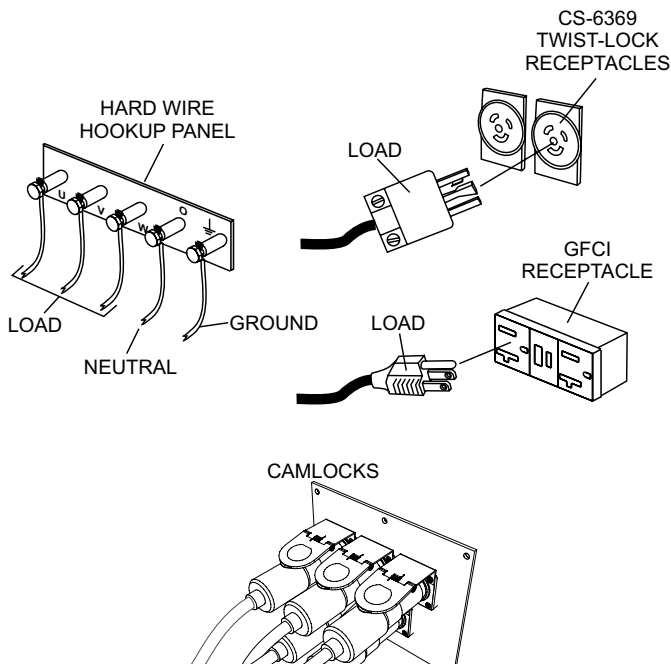

Figure 10. Connecting Loads

## Over Current Relay

An **over current relay** (Figure 11) is connected to the main circuit breaker. In the event of an overload, both the circuit breaker and the over current relay may trip. If the circuit breaker can not be reset, the **reset button** on the over current relay must be pressed. The over current relay is located in the control box.

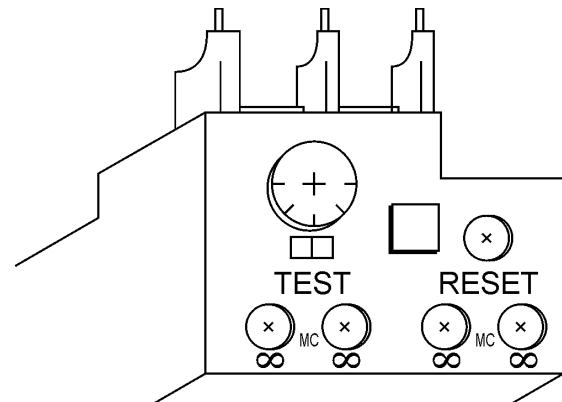

Figure 11. Over Current Relay

### NOTICE

Remember the **overcurrent relay** monitors the current flowing from the **U,V, and W Output Terminal Lugs** to the load.

In the event of a short circuit or over current condition, it will automatically trip the 60 amp main breaker.

To restore power to the **Output Terminal Panel**, press the reset button on the overcurrent relay and place the **main** circuit breaker in the **closed** position (**ON**).

# LOAD APPLICATION

## SINGLE PHASE LOAD

Always be sure to check the nameplate on the generator and equipment to insure the wattage, amperage, frequency, and voltage requirements are satisfactorily supplied by the generator for operating the equipment.

Generally, the wattage listed on the nameplate of the equipment is its rated output. Equipment may require 130—150% more wattage than the rating on the nameplate, as the wattage is influenced by the efficiency, power factor and starting system of the equipment.

### NOTICE

If wattage is not given on the equipment's nameplate, approximate wattage may be determined by multiplying nameplate voltage by the nameplate amperage.

$$\text{WATTS} = \text{VOLTAGE} \times \text{AMPERAGE}$$

The power factor of this generator is 0.8. See Table 5 below when connecting loads.

**Table 5. Power Factor By Load**

Type of Load	Power Factor
Single-phase induction motors	0.4-0.75
Electric heaters, incandescent lamps	1.0
Fluorescent lamps, mercury lamps	0.4-0.9
Electronic devices, communication equipment	1.0
Common power tools	0.8

**Table 6. Cable Selection (60 Hz, Single Phase Operation)**

Current in Amperes	Load in Watts		Maximum Allowable Cable Length			
	At 100 Volts	At 200 Volts	#10 Wire	#12 Wire	#14 Wire	#16 Wire
2.5	300	600	1000 ft.	600 ft.	375 ft.	250 ft.
5	600	1200	500 ft.	300 ft.	200 ft.	125 ft.
7.5	900	1800	350 ft.	200 ft.	125 ft.	100 ft.
10	1200	2400	250 ft.	150 ft.	100 ft.	
15	1800	3600	150 ft.	100 ft.	65 ft.	
20	2400	4800	125 ft.	75 ft.	50 ft.	

CAUTION: Equipment damage can result from low voltage

## THREE PHASE LOAD

When calculating the power requirements for 3-phase power use the following equation:

$$\text{KVA} = \frac{\text{VOLTAGE} \times \text{AMPERAGE} \times 1.732}{1000}$$

### NOTICE

If 3Ø load (kVA) is not given on the equipment nameplate, approximate 3Ø load may be determined by multiplying voltage by amperage by 1.732

### NOTICE

Motors and motor-driven equipment draw much greater current for starting than during operation.

An inadequate size connecting cable which cannot carry the required load can cause a voltage drop which can burn out the appliance or tool and overheat the cable. See Table 6.

- When connecting a resistance load such as an incandescent lamp or electric heater, a capacity of up to the generating set's rated output (kW) can be used.
- When connecting a fluorescent or mercury lamp, a capacity of up to the generating set's rated output (kW) multiplied by 0.6 can be used.
- When connecting an electric drill or other power tools, pay close attention to the required starting current capacity.

When connecting ordinary power tools, a capacity of up to the generating set's rated output (kW) multiplied by 0.8 can be used.

### DANGER

Before connecting this generator to any building's electrical system, a **licensed electrician** must install an **isolation (transfer) switch**. Serious damage to the building's electrical system may occur without this transfer switch.

# GENERATOR OUTPUTS

## GENERATOR OUTPUT VOLTAGES

A wide range of voltages are available to supply voltage for many different applications. Voltages are selected by using the **voltage selector** switch (Figure 12). To obtain some of the voltages as listed in Table 7 (see below) will require a fine adjustment using the **voltage regulator (VR) control knob** located on the control panel.

### Voltage Selector Switch

The voltage selector switch (Figure 12) is located above the output terminal panel's Hard Wire Hook-up Panel. It has been provided for ease of voltage selection..

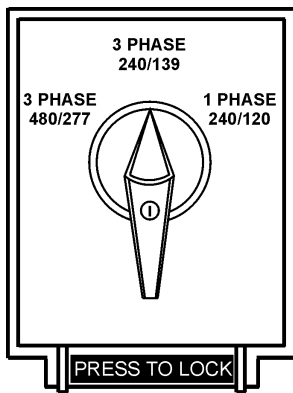

Figure 12. Voltage Selector Switch

**CAUTION**

**NEVER** change the position of the **voltage selector switch** while the engine is running. **ALWAYS** place circuit breaker in the **OFF** position before selecting voltage.

Table 7. Voltages Available						
UVW Output Terminal Lugs	Voltage Selector Switch 3-Phase 240/139V Position			Voltage Selector Switch 3-Phase 480/270V Position		
	3Ø Line-Line	208V	220V	240V	416V	440V
1Ø Line-Neutral	120V	127V	139V	240V	254V	277V
Voltage Selector Switch Single-Phase 240/120V Position						
1Ø Line-Neutral/Line-Line	120V Line-Neutral	N/A	N/A	240V Line-Line	N/A	N/A

## Maximum Amps

Table 8 shows the **maximum** amps the generator can provide. **DO NOT** exceed the maximum amps as listed.

Table 8. Generator Maximum Amps	
Rated Voltage	Maximum Amps
1Ø 120 Volt	55.6 amps (4 wire)
1Ø 240 Volt	27.8 amps (4 wire)
3Ø 240 Volt	60 amps
3Ø 480 Volt	30 amps

## GFCI Receptacle Load Capability

The load capability of the GFCI receptacles is directly related to the voltage being supplied at either the output terminals or the three twist lock auxiliary receptacles.

Figure 15 and Table 10 show what amount of current is available at the GFCI receptacles when the output terminals and twist lock receptacles are in use. Be careful that your load does not to exceed the available current capability at the receptacles.

Table 9. 1Ø GFCI Receptacle Load Capacity	
KW in Use Twist Lock (C6369)	Available Load Current (Amps)
1Ø 240/120V	GFCI Duplex 5-20R 120V
25	0
20.8	5 amps/receptacle
16.7	10 amps/receptacle
12.5	15 amps/receptacle
8.4	20 amps/receptacle

Table 10. 3Ø Generator Maximum Amps	
KVA in Use (UVW Terminals)	Available Load Current (Amps)
3Ø 240/480V	GFCI Duplex 5-20R 120V
70	0 amps/receptacle
65.8	5 amps/receptacle
61.7	10 amps/receptacle
57.5	15 amps/receptacle
53.4	20 amps/receptacle



# GENERATOR OUTPUTS/GAUGE READING

## HOW TO READ THE AC AMMETER AND AC VOLTAGE GAUGES

The AC ammeter and AC voltmeter gauges are controlled by the AC ammeter and AC voltmeter change-over switches.

Both of these switches are located on the control panel and **DO NOT** effect the generator output. They are provided to help observe how much power is being supplied, produced at the UVWO terminals lugs.

Before taking a reading from either gauge, set the **Voltage Selector Switch** (Figure 13) to the position which produces the required voltage (For example, for 3Ø 240V, choose the center 3Ø 240/139V position on the voltage selector switch

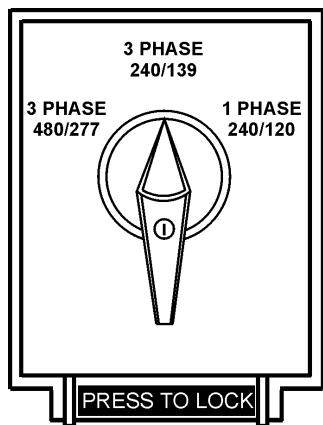

Figure 13. Voltage Selector Switch-240/3Ø Position

## AC Voltmeter Gauge Reading

Place the **AC Voltmeter Change-Over Switch** (Figure 14) in the W-U position and observe the phase to phase voltage reading between the W and U terminals as indicated on the **AC Voltmeter Gauge** (Figure 15).

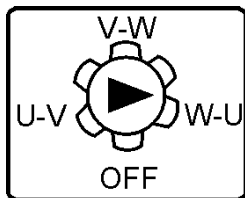

Figure 14. AC Voltmeter Change-Over Switch

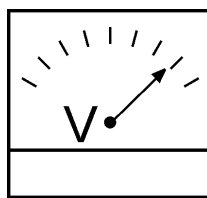

Figure 15. AC Voltmeter Gauge (volt reading on W-U Lug)

## AC Ammeter Gauge Reading

Place the **AC Ammeter Change-Over Switch** (Figure 16) in the U position and observe the current reading (load drain) on the U terminal as indicated on the **AC Ammeter Gauge** (Figure 17). This process can be repeated for terminals V and W.

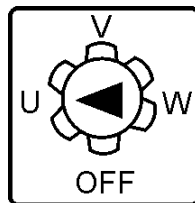

Figure 16. AC Ammeter Change-Over Switch

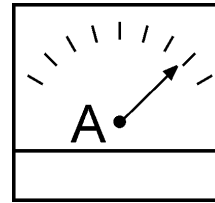

Figure 17. AC Ammeter (Amp reading on U Lug)

### NOTICE

The **ammeter** gauge will only show a reading when the **Output Terminal Lugs** are connected to a load and in use.

# OUTPUT TERMINAL PANEL CONNECTIONS

## UVWO TERMINAL OUTPUT VOLTAGES

Various output voltages can be obtained using the UVWO output terminal lugs. The voltages at the terminals are dependent on the position of the **Voltage Selector Switch** and the adjustment of the **Voltage Regulator Control Knob**.

Remember the voltage selector switch determines the **range** of the output voltage. The voltage regulator (VR) allows the user to increase or decrease the selected voltage.

### 3Ø-240V UVWO Terminal Output Voltages

1. Place the voltage selector switch in the 3Ø 240/139 position as shown in Figure 18.

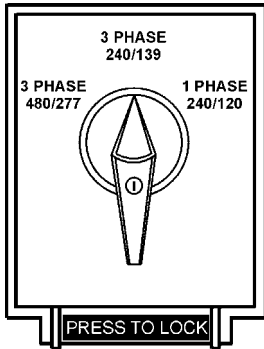

**Figure 18. Voltage Selector Switch  
3Ø-240/139V Position**

2. Connect the load wires to the UVWO terminals as shown in Figure 19.

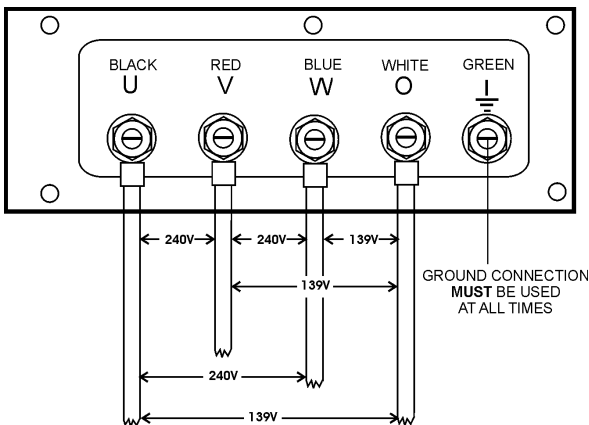

**Figure 19. UVWO Terminal Lugs**

3. Turn the voltage regulator knob (Figure 20) clockwise to increase voltage output, turn counterclockwise to decrease voltage output. Use voltage regulator adjustment knob whenever fine tuning of the output voltage is required.



**Figure 20. Voltage Regulator Knob**

### 3Ø-208V/1Ø-120V UVWO Terminal Output Voltages

1. Place the voltage selector switch in the 3Ø 240/139 position as shown in Figure 18.
2. Connect the load wires to the UVWO terminals as shown in Figure 21.

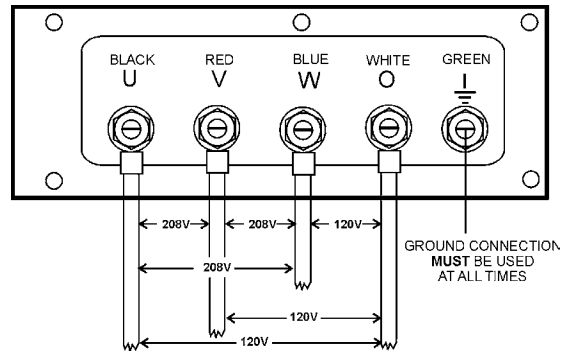

**Figure 21. UVWO Terminal Lugs  
3Ø-208/1Ø-120V Connections**

### NOTICE

To achieve a 3Ø 208V output the voltage selector switch must be in the 3Ø-240/139 position and the voltage regulator must be adjusted to 208V.

# OUTPUT TERMINAL PANEL CONNECTIONS

## 3Ø-480/277V UVWO Terminal Output Voltages

1. Place the voltage selector switch in the 3Ø 480/277 position as shown in Figure 22.

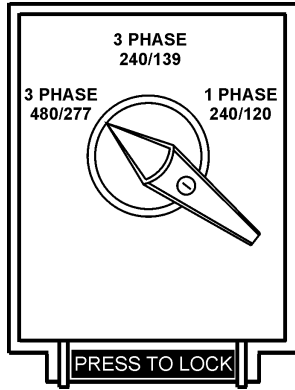

**Figure 22. Voltage Selector Switch  
3Ø-480/277V Position**

2. Connect the load wires to the UVWO terminals as shown in Figure 23.

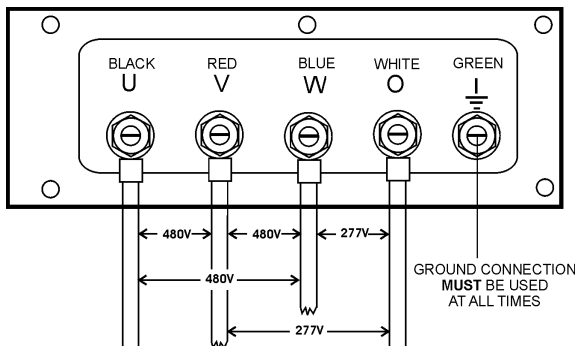

**Figure 23. UVWO Terminal Lugs 3Ø-480V  
Connections**

### NOTICE

**ALWAYS** make sure that the connections to the UVWO terminals are **secure** and **tight**. The possibility of arcing exists, that could cause a fire.

## 1Ø-240/120V UVWO Terminal Output Voltages

1. Place the voltage selector switch in the 1Ø 240/120 position as shown in Figure 24.

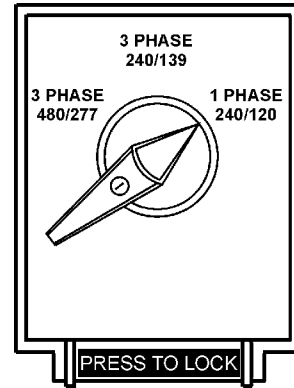

**Figure 24. Voltage Selector Switch  
1Ø-240/120V Position**

2. Connect the load wires to the UVWO terminals as shown in Figure 25.

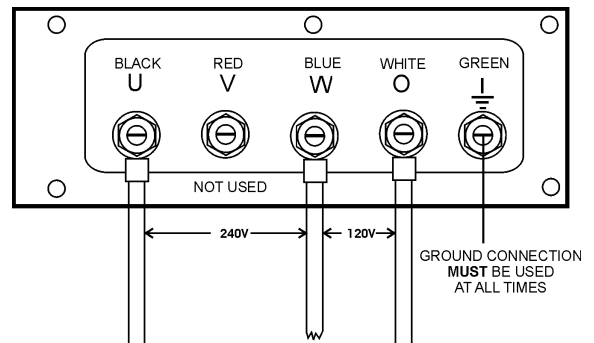

**Figure 25. UVWO Terminal Lugs  
1Ø-240/120V Connection**

3. Turn the voltage regulator knob ("Figure 20. Voltage Regulator Knob" on page 26) clockwise to increase voltage output, turn counterclockwise to decrease voltage output. Use voltage regulator adjustment knob whenever fine tuning of the output voltage is required.

## CIRCUIT BREAKERS

To protect the generator from an overload, a 3-pole, 60 amp, main circuit breaker is provided to protect the **U, V, and W Output Terminals** from overload. In addition two single-pole, 20 amp **GFCI** circuit breakers are provided to protect the GFCI receptacles from overload. Three 50 amp **load** circuit breakers have also been provided to protect the auxiliary receptacles from overload. Make sure to switch **ALL** circuit breakers to the **OFF** position prior to starting the engine.

## LUBRICATION OIL

Fill the engine crankcase with lubricating oil through the filler hole, but **DO NOT** overfill. Make sure the generator is level and verify that the oil level is maintained between the two notches (Figure 26) on the dipstick. See Table 11 for proper selection of engine oil.

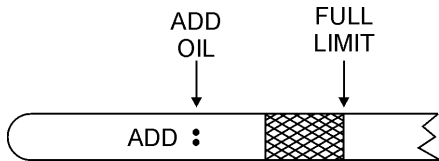

**Figure 26. Engine Oil Dipstick**

When checking the engine oil, be sure to check if the oil is clean. If the oil is not clean, drain the oil by removing the oil drain plug, and refill with the specified amount of oil as outlined in the **Isuzu Owner's Manual**. Oil should be warm before draining.

When replacing engine oil please refill using API service class CJ-4 SAE or JASO DH-2 engine oil.

Table 11. Recommended Motor Oil		OIL: SAE	
°F	°C		
122	50		
104	40	10W/40	30
86	30		
68	20		
50	10		
32	0		
-14	-10	5W/30	10W/40
-4	-20		
-22	-30	15W/30	10W/30
-40	-40	10W	20W/40
		ARCTIC OIL	

## FUEL CHECK

### **!** DANGER



Fuel spillage on a **hot** engine can cause a **fire** or **explosion**. If fuel spillage occurs, wipe up the spilled fuel completely to prevent fire hazards. **NEVER** smoke around or near the generator.

## Refilling the Fuel System

### **!** CAUTION

**ONLY** properly trained personnel who have read and understand this section should refill the fuel tank system.

**ALWAYS** fill the fuel tank (Figure 27) with clean fresh **#2 diesel fuel**. **DO NOT** fill the fuel tank beyond its capacity.

Pay attention to the fuel tank capacity when replenishing fuel. The fuel tank cap must be closed tightly after filling. Handle fuel in a safety container. If the container does not have a spout, use a funnel. Wipe up any spilled fuel immediately.

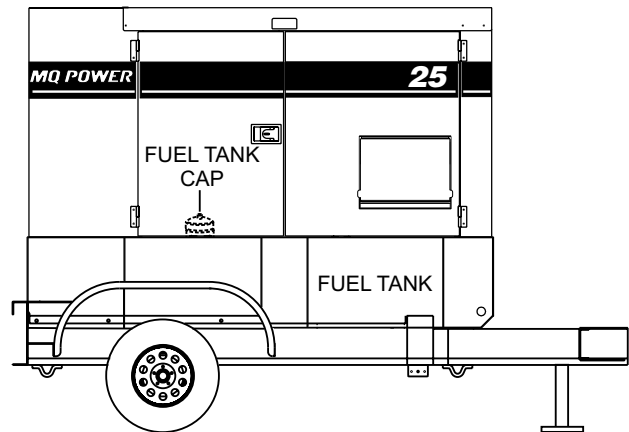

**Figure 27. Fuel Tank**

# INSPECTION/SETUP

## Refueling Procedure:

### WARNING



**Diesel fuel** and its vapors are dangerous to your health and the surrounding environment. Avoid skin contact and/or inhaling fumes.

1. **Level Tanks** — Make sure fuel cells are level with the ground. Failure to do so will cause fuel to spill from the tank before reaching full capacity (Figure 28).

### CAUTION

**ALWAYS** place trailer on firm level ground before refueling to prevent spilling and maximize the amount of fuel that can be pumped into the tank.

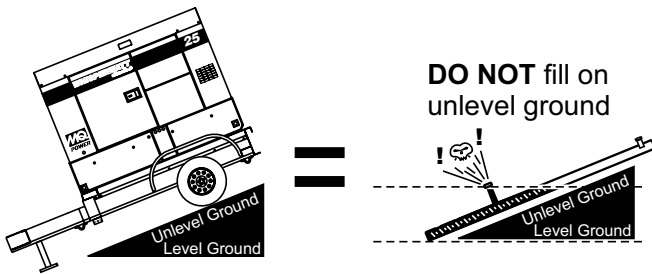

Figure 28. Only Fill on Level Ground

### NOTICE

**ONLY** use #2 diesel fuel when refueling.

2. Open cabinet doors on the “right side” of the generator (from generator control panel position). Remove fuel cap and fill tank (Figure 29).

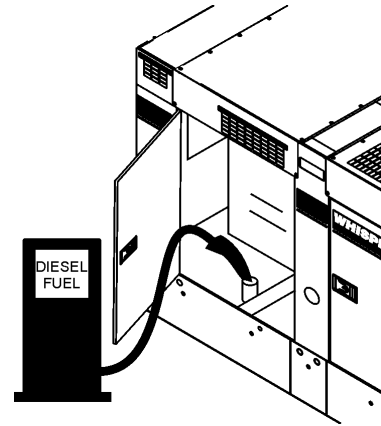

Figure 29. Fueling the Generator

3. **NEVER overfill fuel tank** — It is important to read the fuel gauge when filling trailer fuel tank. **DO NOT** wait for fuel to rise in filler neck (Figure 30).

FUEL GAUGE LOCATED ON CONTROL PANEL

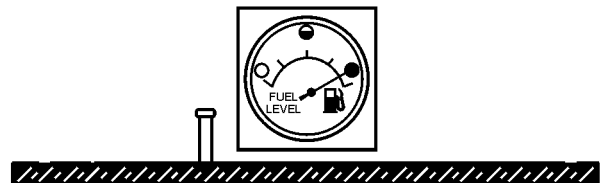

Figure 30. Full Fuel Tank

### CAUTION

**DO NOT OVERFILL** fuel system. Leave room for fuel expansion. Fuel expands when heated (Figure 31).

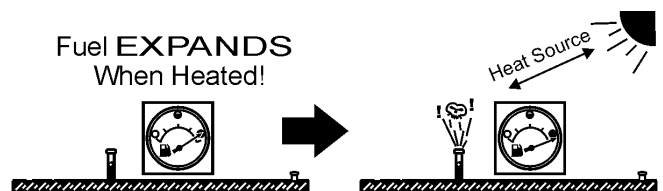



Figure 31. Fuel Expansion

## COOLANT (ANTIFREEZE/SUMMER COOLANT/WATER)

Isuzu recommends antifreeze/summer coolant for use in their engines, which can be purchased in concentrate (and mixed with 50% demineralized water) or pre-diluted. See the **Isuzu Engine Owner's Manual** for further details.

**WARNING**



If adding coolant/antifreeze mix to the radiator, **DO NOT** remove the radiator cap until the unit has completely cooled. The possibility of **hot!** coolant exists which can cause severe burns.

Day-to-day addition of coolant is done from the recovery tank. When adding coolant to the radiator, **DO NOT** remove the radiator cap until the unit has completely cooled. See Table 12 for engine, radiator, and recovery tank coolant capacities. Make sure the coolant level in the recovery tank is always between the "H" and the "L" markings.

Table 12. Coolant Capacity	
Engine and Radiator	2.3 gal (8.8 liters)
Reserve Tank	N/A

### Operation in Freezing Weather

When operating in freezing weather, be certain the proper amount of antifreeze (Table 13) has been added.

Table 13. Anti-Freeze Operating Temperatures		
Vol % Anti-Freeze	Freezing Point	
	°C	°F
50	-37	-34

**NOTICE**

When the antifreeze is mixed with water, the antifreeze mixing ratio **must be** less than 50%.

## Cleaning the Radiator

The engine may overheat if the radiator fins become overloaded with dust or debris. Periodically clean the radiator fins with compressed air. Cleaning inside the machine is dangerous, so clean only with the engine turned off and the **negative** battery terminal disconnected.

## AIR CLEANER

Periodic cleaning/replacement is necessary. Inspect air cleaner in accordance with the **Isuzu Engine Owner's Manual**.

## FAN BELT TENSION

A slack fan belt may contribute to overheating, or to insufficient charging of the battery. Inspect the fan belt for damage and wear and adjust it in accordance with the **Isuzu Engine Owner's Manual**.

The fan belt tension is proper if the fan belt bends 10 to 15 mm (Figure 32) when depressed with the thumb as shown below.

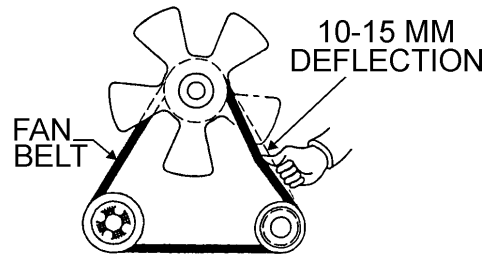



Figure 32. Fan Belt Tension

**CAUTION**



**NEVER** place hands near the belts or fan while the generator set is running.

## BATTERY

This unit is of negative ground **DO NOT** connect in reverse. Always maintain battery fluid level between the specified marks. Battery life will be shortened, if the fluid level are not properly maintained. Add only distilled water when replenishment is necessary.

**DO NOT** over fill. Check to see whether the battery cables are loose. Poor contact may result in poor starting or malfunctions. **Always** keep the terminals firmly tightened. Coating the terminals with an approved battery terminal treatment compound. Replace battery with only recommended type battery. The battery type used in this generator is BCI Group 27.

The battery is sufficiently charged if the specific gravity of the battery fluid is 1.28 (at 68° F). If the specific gravity should fall to 1.245 or lower, it indicates that the battery is dead and needs to be recharged or replaced.

Before charging the battery with an external electric source, be sure to disconnect the battery cables.

### Battery Cable Installation

**ALWAYS** be sure the battery cables (Figure 33) are properly connected to the battery terminals as shown below. The **red cable** is connected to the positive terminal of the battery, and the **black cable** is connected to the negative terminal of the battery.

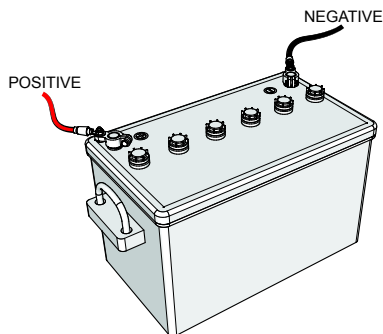
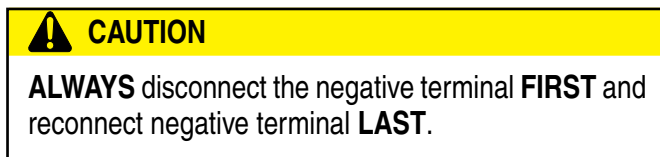

Figure 33. Battery Connections

When connecting battery do the following:

1. **NEVER** connect the battery cables to the battery terminals when the **Auto-Off/Reset-Manual Switch** is in either the **AUTO** or **MANUAL** position. **ALWAYS** make sure that this switch is in the **OFF/RESET** position when connecting the battery.
2. Place a small amount of battery terminal treatment compound around both battery terminals. This will ensure a good connection and will help prevent corrosion around the battery terminals.

### NOTICE

If the battery cable is connected incorrectly, electrical damage to the generator will occur. Pay close attention to the polarity of the battery when connecting the battery.

### CAUTION

Inadequate battery connections may cause poor starting of the generator, and create other malfunctions.

## ALTERNATOR

The polarity of the alternator is negative grounding type. When an inverted circuit connection takes place, the circuit will be in short circuit instantaneously resulting the alternator failure.

**DO NOT** put water directly on the alternator. Entry of water into the alternator can cause corrosion and damage the alternator.

## WIRING

Inspect the entire generator for bad or worn electrical wiring or connections. If any wiring or connections are exposed (insulation missing) replace wiring immediately.

## PIPING AND HOSE CONNECTION

Inspect all piping, oil hose, and fuel hose connections for wear and tightness. Tighten all hose clamps and check hoses for leaks.

If any hose (**fuel or oil**) lines are defective replace them immediately.



# GENERATOR START-UP PROCEDURE (MANUAL)

## BEFORE STARTING

### CAUTION

The engine's exhaust contains harmful emissions. **ALWAYS** have adequate ventilation when operating. Direct exhaust away from nearby personnel.

### WARNING

**NEVER** manually start the engine with the main, GFCI or auxiliary circuit breakers in the **ON** (closed) position.

1. Place the **main, G.F.C.I., and aux.** circuit breakers (Figure 34) in the **OFF** position prior to starting the engine.

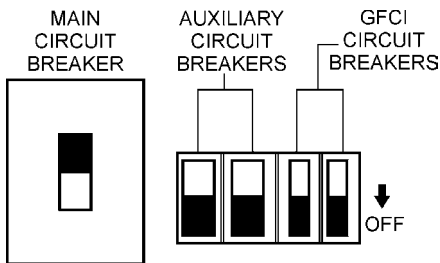

**Figure 34. Main, Aux. and GFCI Circuit Breakers (OFF)**

2. Make sure the **voltage change-over board** has been configured for the desired output voltage.
3. Connect the load to the **receptacles** or the **output terminal lugs** as shown in Figure 10. These load connection points can be found on the output terminal panel and the output terminal panel's hard wire hookup panel.
4. Tighten terminal nuts securely to prevent load wires from slipping out.
5. Close all engine enclosure doors (Figure 35).

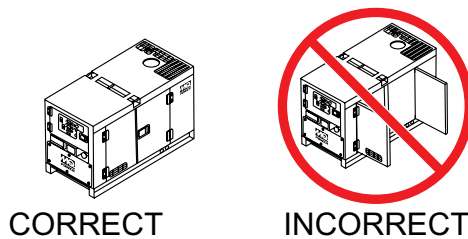

**Figure 35. Engine Enclosure Doors**

## STARTING (MANUAL)

1. Place the **Auto-Off/Reset Manual Switch** in the **MANUAL** position to start the engine (Figure 36).

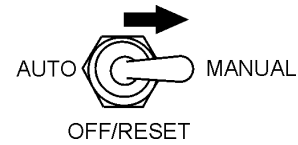

**Figure 36. Auto-Off/Reset Manual;Switch (Manual Position)**

### NOTICE

If engine fails to start in a specified number attempts, the shutdown lamp will illuminate and the Auto-Off/Reset Switch must be place in the Off/Reset position before the engine can be restarted.

### NOTICE

Engine will pre-heat automatically in cold weather conditions. "Glow Plug Hold" message will be displayed and the engine will start automatically after pre-heating.

2. Once the engine starts, let the engine run for 1-2 minutes (let engine idle longer in cold weather conditions). Listen for any abnormal noises. If any abnormalities exist, shut down the engine and correct the problem.
3. The generator's frequency meter (Figure 37) should be displaying the 60 cycle output frequency in **HERTZ**.

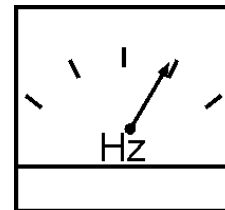
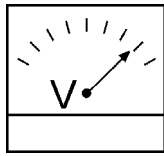

**Figure 37. Frequency Meter**



# GENERATOR START-UP PROCEDURE (MANUAL)

4. The generator's AC-voltmeter (Figure 38) will display the generator's output in **VOLTS**. If the voltage is not within the specified tolerance.



**Figure 38. Voltmeter**

5. Use the voltage adjustment control knob (Figure 39) to increase or decrease the desired voltage.

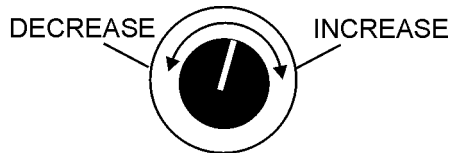

**Figure 39. Voltage Adjust Control Knob**

6. The ammeter (Figure 40) will indicate **zero amps** with no load applied. When a load is applied, the ammeter will indicate the amount of current that the load is drawing from the generator.

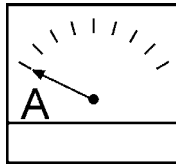

**Figure 40. Ammeter (No Load)**

7. The engine oil pressure gauge (Figure 41) will indicate the oil pressure of the engine. Under normal operating conditions the oil pressure is approximately 35 to 65 psi. (193~586 kPa).

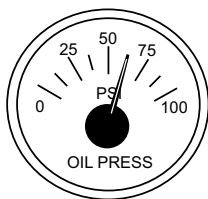

**Figure 41. Oil Pressure Gauge**

8. The **coolant temperature gauge** (Figure 42) will indicate the coolant temperature. Under normal operating conditions the coolant temperature should be between 180°~225°F (75°~95°C) (**Green Zone**).

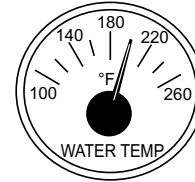

**Figure 42. Coolant Temperature Gauge**

9. The **tachometer gauge** (Figure 43) will indicate the speed of the engine when the generator is operating. Under normal operating conditions this speed is approximately 1800 RPM's.

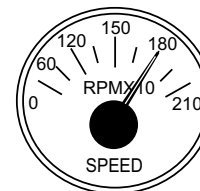

**Figure 43. Engine Tachometer Gauge**

10. Place the **main, GFCI, and aux.** circuit breakers in the **ON** position (Figure 44).

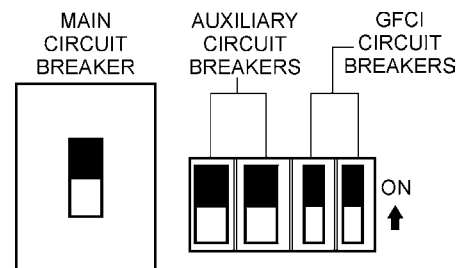

**Figure 44. Main, Aux. and GFCI Circuit Breakers (ON)**

11. Observe the generator's ammeter (Figure 45) and verify it reads the anticipated amount of current with respect to the load. The ammeter will only display a current reading if a load is in use.

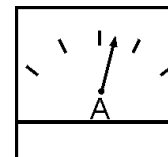

**Figure 45. Ammeter (Load)**

12. The generator will run until manually stopped or an abnormal condition occurs.

# GENERATOR START-UP PROCEDURE (AUTO MODE)

## STARTING (AUTO MODE)

### DANGER



Before connecting this generator to any building's electrical system, a **licensed electrician** must install an **isolation (transfer) switch**. Serious damage to the building's electrical system may occur without this transfer switch.

### CAUTION

When connecting the generator to a isolation (transfer) switch, **ALWAYS** have power applied to the generator's internal battery charger. This will ensure that the engine will not fail due to a dead battery.

### NOTICE

When the generator is set in the **AUTO** mode, the generator will **automatically start** in the event of commercial power falling below a prescribed level by means of a contact closure that is generated automatically by a transfer switch.

### WARNING

When running the generator in the **AUTO** mode, remember the generator can start up at any time without warning. **NEVER** attempt to perform any maintenance when the generator is in the auto mode.

### CAUTION

The engine speed switch **must** be set to the "High" position when running in the **auto-start** mode. Failing to set the switch in the proper position can result in damage to your generator when it turns on.

### NOTICE

When the **Auto Off/Reset Manual** switch is placed in the **AUTO** position, the engine glow plugs will be warmed and the engine will start automatically.

When starting generator in **AUTO** mode use the "Manual Start-up" procedure except where noted (see below).

1. Perform steps 1 through 5 in the Before Starting section as outlined in the Manual Starting Procedure.
2. Place the **Auto Off/Reset Manual Switch** (Figure 46) in the **AUTO** position.



Figure 46. Auto Off/Reset Manual Switch (AUTO)

3. Continue operating the generator as outlined in the Manual Start-up procedure (start at step 3).

# GENERATOR SHUT-DOWN PROCEDURES

## WARNING

**NEVER** stop the engine suddenly except in an emergency.

### NORMAL SHUTDOWN PROCEDURE

To shutdown the generator, use the following procedure:

1. Place both the **MAIN, GFCI and LOAD** circuit breakers as shown in Figure 47 to the **OFF** position.

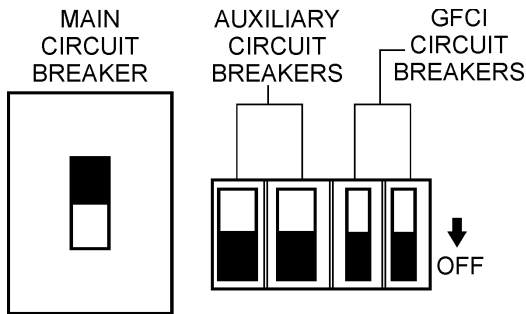

**Figure 47. Main, Aux. and GFCI Circuit Breakers (OFF)**

2. Let the engine cool by running it at low speed for 3-5 minutes with no load applied.
3. Place the **Auto Off/Reset Manual Switch** (Figure 48) in the **OFF/RESET** position.



**Figure 48. Auto Off/Reset Manual Switch (Off/Reset)**

4. Verify that all status LEDs on the ECU control panel are **OFF** (not lit).
5. Remove all loads from the generator.
6. Inspect entire generator for any damage or loosening of components that may have occurred during operation.

### EMERGENCY SHUTDOWN PROCEDURE

1. Place both the **MAIN, GFCI and LOAD** circuit breakers as shown in Figure 47 to the **OFF** position.

### AUTOMATIC SHUT-DOWN SYSTEM

This unit is equipped with safety devices to automatically stop the engine in the event of low oil pressure, approximately 14 psi (97 kPa), or high water temperature, approximately 212° F (100° C), overspeed approximately +15%. The alarm lamps on the ECU illuminate to signify the reason for the shutdown.

## NOTICE

Before inspecting generator, check that the Auto/Manual switch is in the **OFF/RESET** position, and place all circuit breakers in the **OFF** position. Allow sufficient time for adequate cooling. When ready to restart, complete all steps in the Generator Startup Procedure section of this manual.

# MAINTENANCE

Table 14. Inspection/Maintenance		10 Hrs DAILY	250 Hrs	500 Hrs or Every 12 Months	3000 Hrs or Every 36 Months	OTHER
<b>Engine</b>	Check Engine Oil and Coolant Levels	X				
	Check Fuel Filter/Water Separator Bowl	X				
	Check Air Cleaner	X				
	Check Air Cleaner Element	X				
	Check for Leaks/Hoses/Clamps	X				
	Check for Loosening of Parts	X				
	Change Engine Oil and Oil Filter * 1		X			
	Clean Unit, Inside and Outside		X			
	Replace Fuel Filter Elements			X		
	Check Engine Mounts			X		
	Service Battery			X		
	Check Air Intake Hoses			X		
	Check Fan Belt Condition			X		
	Check Automatic Belt Tensioner			X		
	Check Electrical Ground Connection			X		
	Clean Radiator, Check Cooling System			X		
	Coolant Solution Analysis, Add SCA's As Required			X		
	Pressure Test Cooling System			X		
	Check Engine Speed			X		
	Test Thermostats				X	
Test Glow Plugs				X		
Flush and Refill Cooling System					2 yrs. or 2000 hrs.	
Clean Inside of Fuel Tank					1000 hrs.	
Replace Air Cleaner Elements * 2					As Required	
<b>Generator</b>	Measure Insulation Resistance Over 3M ohms		X			
	Check Rotor Rear Support Bearing			X		

\*1 During initial operation of a new engine, change oil and filter between a minimum of 100 hrs. and a maximum of 250 hrs. Service interval depends on type of oil.

\*2 Replace primary air filter element when restriction indicator shows a vacuum of 625 mm (25 in. H<sub>2</sub>O).

## GENERAL INSPECTION

Prior to each use, the generator should be cleaned and inspected for deficiencies. Check for loose, missing or damaged nuts, bolts or other fasteners. Also check for fuel, oil, and coolant leaks. Use Table 14 as a general maintenance guideline **Engine Side** (Refer to the Engine Instruction Manual).

## AIR CLEANER

Every 250 hours: Remove air cleaner element (Figure 49) and clean the heavy duty paper element with light spray of compressed air. Replace the air cleaner as needed.

### Air Cleaner with Dust Indicator

This indicator (Figure 49) is attached to the air cleaner. When the air cleaner element is clogged, air intake restriction becomes greater and the dust indicator signal shows **RED** meaning the element needs changing or service. After changing the air element, press the dust indicator button to reset the indicator.

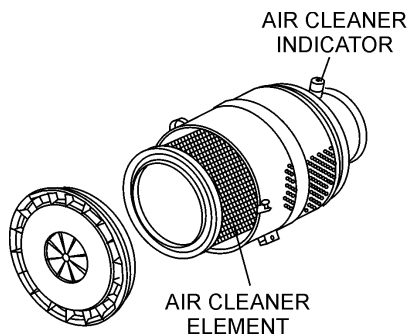

Figure 49. Air Cleaner/Indicator

### NOTICE

The air filter should not be changed until the indicator reads “RED”. Dispose of old air filter. It may not be cleaned or reused..

If the engine is operating in very **dusty** or **dry grass** conditions, a clogged air cleaner will result. This can lead to a loss of power, excessive carbon buildup in the combustion chamber and high fuel consumption. Change air cleaner more **frequently** if these conditions exist.

## FUEL ADDITION

Add diesel fuel (the grade may vary according to season and locations).

### Removing Water from the Fuel Tank

After prolonged use, water and other impurities accumulate in the bottom of the tank. Occasionally inspect the fuel tank for water contamination and drain the contents if required.

During cold weather, the more empty volume inside the tank, the easier it is for water to condense. This can be reduced by keeping the tank full with diesel fuel.

### Cleaning Inside the Fuel Tank

Drain the fuel inside the fuel tank completely. Using a spray washer (Figure 50) wash out any deposits or debris that have accumulated inside the fuel tank.

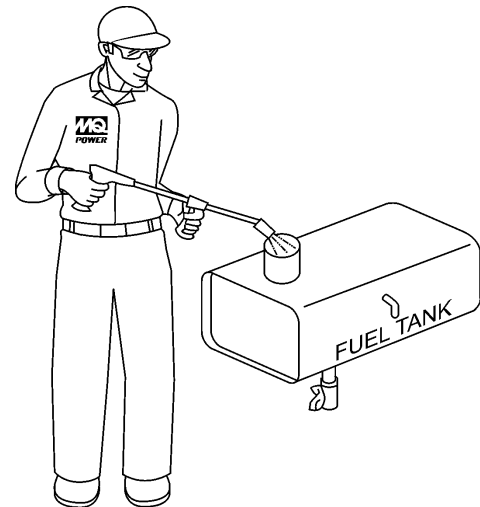

Figure 50. Fuel Tank Cleaning

## FUEL TANK INSPECTION

In addition to cleaning the fuel tank, the following components should be inspected for wear:

- **Rubber Suspension** — look for signs of wear or deformity due to contact with oil. Replace the rubber suspension if necessary.
- **Fuel Hoses** — inspect nylon and rubber hoses for signs of wear, deterioration and hardening.
- **Fuel Tank Lining** — inspect the fuel tank lining for signs of excessive amounts of oil or other foreign matter.

## Replacing Fuel Filter

- Replace the fuel filter cartridge with new one every 500 hours or so.
- Loosen the drain plug at the lower top of the fuel filter. Drain the fuel in the fuel body together with the mixed water. **DO NOT** spill the fuel during disassembly.
- Vent any air.

## AIR REMOVAL

If air enters the fuel injection system of a diesel engine, starting becomes impossible. After running out of fuel, or after disassembling the fuel system, bleed the system according to the following procedure. See the **Isuzu Engine Manual** for details.

To restart after running out of fuel, turn the switch to the “**ON**” position for 15-30 seconds. Try again, if needed. This unit is equipped with an automatic air bleeding system.

## CHECK OIL LEVEL

Check the crankcase oil level prior to each use, or when the fuel tank is filled. Insufficient oil may cause severe damage to the engine. Make sure the generator is level. The oil level must be between the two notches on the dipstick as shown in Figure 26.

## Replacing Oil Filter

- Remove the old oil filter.
- Apply a film of oil to the gasket on the new oil filter.
- Install the new oil filter.
- After the oil cartridge has been replaced, the engine oil will drop slightly. Run the engine for a while and check for leaks before adding more oil if needed. Clean excessive oil from engine.

## FLUSHING OUT RADIATOR AND REPLACING COOLANT

- Open both cocks located at the crankcase side and at the lower part of the radiator and drain coolant. Open the radiator cap while draining. Remove the overflow tank and drain.
- Check hoses for softening and kinks. Check clamps for signs of leakage.
- Tighten both cocks and replace the overflow tank.
- Replace with coolant as recommended by the engine manufacturer.
- Close radiator cap tightly.
- Flush the radiator by running clean tap water through radiator until signs of rust and dirt are removed. **DO NOT** clean radiator core with any objects, such as a screwdriver.

### WARNING



Allow engine to **cool** when flushing out radiator. Flushing the radiator while hot could cause serious burns from water or steam.

## RADIATOR CLEANING

The radiator (Figure 51) should be sprayed (cleaned) with a high pressure washer when excessive amounts of dirt and debris have accumulated on the cooling fins or tube. When using a high pressure washer, stand at least 5 feet (1.5 meters) away from the radiator to prevent damage to the fins and tube.

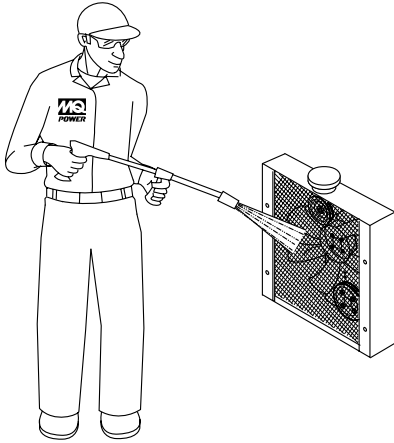

Figure 51. Radiator Cleaning

## GENERATOR STORAGE

For long term storage of the generator the following is recommended:

- Drain the fuel tank completely. Treat with a fuel stabilizer if necessary.
- Completely drain the oil from the crankcase and refill if necessary with fresh oil.
- Clean the entire generator, internal and external.
- Cover the generating set and store in a clean, dry place.
- Disconnect the battery.
- Make sure engine coolant is at proper level.
- If generator is mounted on a trailer, jack trailer up and place on blocks so tires do not touch the ground or block and completely remove the tires.

## JACKET WATER HEATER AND INTERNAL BATTERY CHARGER 120 VAC INPUT RECEPTACLES (OPTIONAL)

This generator can be optionally equipped with two 120 VAC, 20 amp input receptacles located on the output terminal panel.

The purpose of these receptacles is to provide power via commercial power to the **jacket water heater** and **internal battery charger**.

These receptacles will **ONLY** function when commercial power has been supplied to them (Figure 52). To apply commercial power to these receptacles, a power cord of adequate size will be required (See Table 6).

When using the generator in **hot** climates there is no reason to apply power to jacket water heater. However, if the generator will be used in **cold** climates it is always a good idea to apply power to the jacket water heater at all times.

To apply power to the jacket water heater simply apply power to the jacket water heater receptacle via commercial power using a power cord of adequate size.

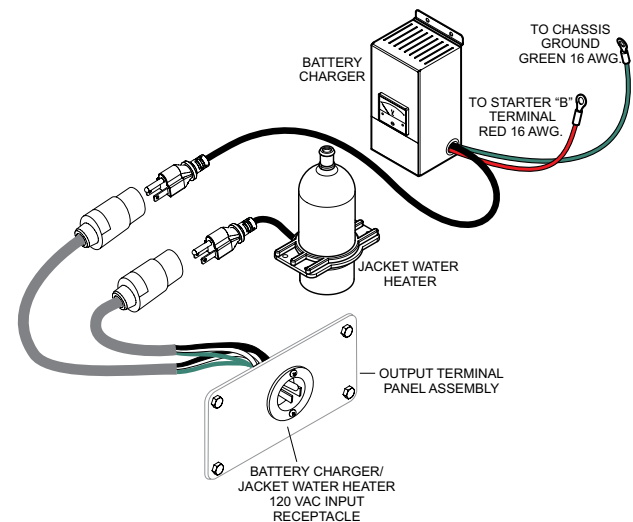

Figure 52. Battery Charger and Jacket Water Heater Power Connections

If the generator will be used daily, the battery should normally not require charging. If the generator will be idle (not used) for long periods of time, apply power to the battery charger receptacle via commercial power using a power cord of adequate size.

### NOTICE

To ensure adequate starting capability, always have power applied to the generator's internal battery charger.

## **EMISSION CONTROL**

The emission control system employed with the Isuzu 4LE2T diesel engine consist of a Diesel Oxidation Catalyst (DOC).

This device oxidizes large amounts of harmful nitrogen oxides (NOx) and particulate matter (PM) which are emitted by diesel engines. These exhaust emissions pose serious environmental and health risks. No maintenance or service is required for the DOC device used on this generator.

### **Diesel Oxidation Catalyst (DOC)**

The DOC does not filter particles it oxidizes them. This catalyst (honeycomb like structure) uses a chemical process to break down pollutants in the exhaust stream into less harmful components. In general this catalyst collects/burns accumulated particulates. The DOC contains palladium and platinum which serve as a catalysts to oxidize hydrocarbons and carbon monoxide.



# TRAILER MAINTENANCE

The following trailer maintenance guidelines are intended to assist the operator in preventive maintenance.

## TRAILER BRAKES

Properly functioning brake shoes and drums are essential to ensure safety. The brakes should be inspected the first 200 miles of operation. This will allow the brake shoes and drums to seat properly. After the first 200 mile interval, inspect the brakes every 3,000 miles. If driving over rough terrain, inspect the brakes more frequently.

## HYDRAULIC BRAKES

If your trailer has hydraulic brakes, they function the same way the surge brakes do on your tow vehicle. The hydraulic braking system must be inspected at least as often as the brakes on the tow vehicle, but no less than once per year. This inspection includes an assessment of the condition and proper operation of the wheel cylinders, brake shoes, brake drums and hubs.

## MANUALLY ADJUSTING THE BRAKES

Most axles are fitted with a brake mechanism that will adjust the brakes during a hard stop. However, some braking systems are not automatically adjusted by hard stopping. These brakes require manual adjustment. The following steps apply to adjust most manually adjustable brakes.

1. Jack up the trailer and secure it on adequate capacity jackstands.
2. Be sure the wheel and brake drum rotate freely.
3. Remove the adjusting-hole cover from the adjusting slot on the bottom of the brake backing plate.
4. With a screwdriver or standard adjusting tool, rotate the starwheel of the adjuster assembly to expand the brake shoes. Adjust the brake shoes out until the pressure of the linings against the drum makes the wheel very difficult to turn. Note: Your trailer maybe equipped with drop spindle axles. See axle manual for your axle type. You will need a modified adjusting tool for adjusting the brakes in these axles. With drop spindle axles, a modified adjusting tool with about an 80 degree angle should be used.
5. Rotate the starwheel in the opposite direction until the wheel turns freely with a slight drag.

6. Replace the adjusting-hole cover.
7. Repeat the above procedure on all brakes.
8. Lower the trailer to the ground.

Check the fluid level in the master cylinder reservoir at least every three months. If you tow your trailer an average of 1,000 miles per month in a hot and dry environment, you must check the brake fluid level once a month. The brake fluid reservoir is located on the tongue of the trailer. Always fill with clean, uncontaminated DOT 4 brake fluid.

Figure 53 below displays the major hydraulic brake components that will require inspection and maintenance. Please inspect these components as required using steps 1 through 6 as referenced in the “Manually Adjusting The Brakes” section on this page. See Table 1 for Hydraulic Brake Troubleshooting.

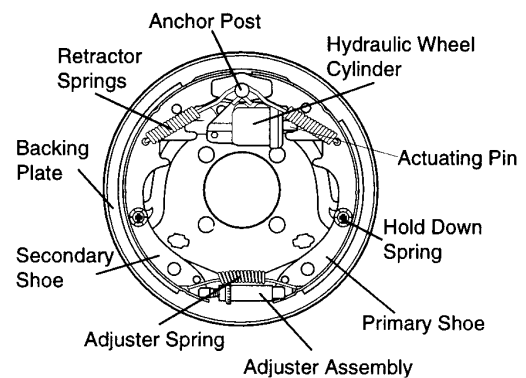

**Figure 53. Hydraulic Brake Components**

## HYDRAULIC BRAKE ACTUATOR

The hydraulic brake actuator (Figure 54) is the mechanism that activates the trailer's brake system. This actuator changes fluid power into mechanical power. Therefore, the fluid level must be checked frequently to assure that the brakes function properly.

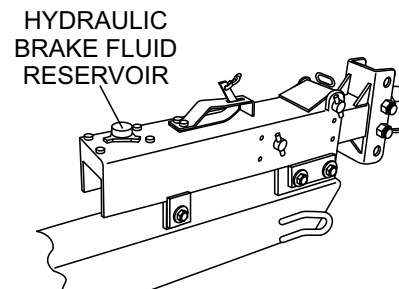

**Figure 54. Hydraulic Brake Actuator**

# TRAILER MAINTENANCE

## WARNING

Failure to maintain proper fluid level in the actuator may result in loss of braking action which could cause severe property damage, injury or death.

Periodically check the actuator mounting fasteners for damage or loosening. Inspect the actuator for worn or damaged parts. As you are towing your trailer, be aware of any changes in braking quality. This could be an early warning of brake or actuator malfunction and requires immediate attention. Consult a certified brake specialist to make necessary adjustment or repairs.

Symptom	Possible Cause	Solution
No Brakes	Brake line broken or kinked?	Repair or replace.
Weak Brakes or Brakes Pull to One Side	Brake lining glazed?	Reburnish or replace.
	Trailer overloaded?	Correct weight.
	Brake drums scored or grooved?	Machine or replace.
	Tire pressure correct?	Inflate all tires equally.
	Tires unmatched on the same axle?	Match tires.
Locking Brakes	Brake components loose, bent or broken?	Replace components.
	Brake drums out-of-round?	Replace.
Noisy Brakes	System lubricated?	Lubricate.
	Brake components correct?	Replace and correct.
Dragging Brakes	Brake lining thickness incorrect or not adjusted correctly?	Install new shoes and linings.
	Enough brake fluid or correct fluid?	Replace rubber parts fill with dot 4 fluid.

## ADJUSTABLE CHANNEL

Your trailer may be equipped with an adjustable channel (Figure 55) that allows the coupler to be raised or lowered to a desired height. Periodically check the channel bolts for damage or loosening.

## NOTICE

When replacing channel mounting hardware (nuts, bolts and washers), **NEVER** substitute substandard hardware. Pay close attention to **bolt length** and **grade**. **ALWAYS** use manufacturer's recommended parts when replacing channel mounting hardware.

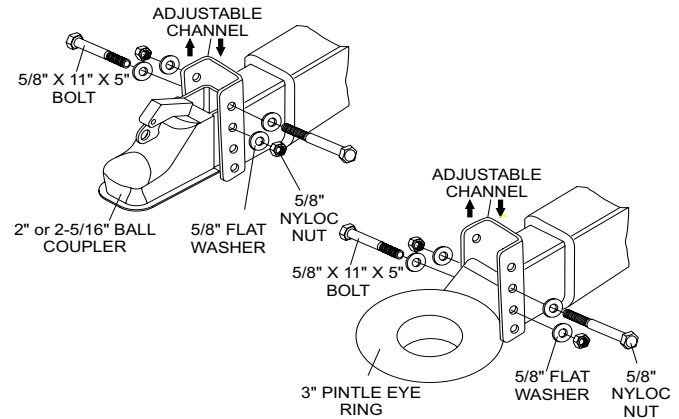

Figure 55. Adjustable Channel

## Wheel Bearings

Wheel bearings (Figure 56) must be inspected and lubricated once a year or 12,000 miles to insure safe operation of your trailer.

If trailer wheel bearings are immersed in water, they must be replaced.

## DANGER

If trailer wheels are under water for a long period of time, wheel bearings may fail. If this is the case, service wheel bearings immediately.

The possibility exists of the wheels falling off causing equipment damage and severe bodily harm even death!

If the trailer has not been used for an extended amount of time, have the bearings inspected and packed more frequently, at least every six months and prior to use.

Follow the steps below to disassemble the wheel hub and service the wheel bearings. See Figure 56.

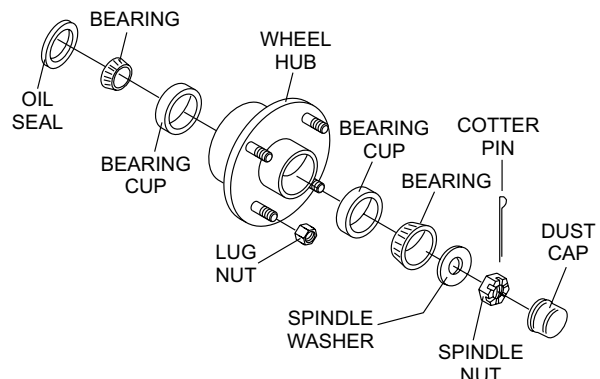

Figure 56. Wheel Hub Components

# TRAILER MAINTENANCE

- After removing the dust cap, cotter pin, spindle nut and spindle washer, remove the hub to inspect the bearings for wear and damage.
- Replace bearings that have flat spots on rollers, broken roller cages, rust or pitting. Always replace bearings and cups in sets. The inner and outer bearings are to be replaced at the same time.
- Replace seals that have nicks, tears or wear.
- Lubricate the bearings with a high quality EP-2 automotive wheel bearing grease.

## WHEEL HUB ADJUSTMENT

Every time the wheel hub is removed and the bearings are reassembled, follow the steps below to check the wheel bearings for free running and adjust.

- Turn the hub slowly, by hand, while tightening the spindle nut until you can no longer turn the hub by hand.
- Loosen the spindle nut just until you are able to turn it (the spindle nut) by hand. Do not turn the hub while the spindle nut is loose.
- Install a new cotter pin through the spindle nut and axle.
- Check the adjustments. Both the hub and the spindle nut should be able to move freely (the spindle nut motion will be limited by the cotter pin).

### **!** DANGER

**NEVER** crawl under the trailer unless it is on firm and level ground and resting on properly placed and secured jackstands.

The possibility exists of the trailer falling thus causing equipment damage and severe bodily harm even death!

### **!** DANGER

When performing trailer inspection and maintenance activities, you must jack up the trailer using jacks and jackstands.

When jacking and using jackstands, place them so as to clear wiring, brake lines, and suspension parts (i.e., springs, torsion bars). Place jacks and jackstands inside of the perimeter strip on the supporting structure to which the axles are attached.

### **!** DANGER

Improper weld repair will lead to early failure of the trailer structure and can cause serious injury or death.

**DO NOT** repair cracked or broken welds unless you have a certified welder perform the repair. If not, have the welds repaired by your dealer.

### **!** WARNING

If the trailer is involved in an accident, have it inspected immediately by qualified personnel. In addition, the trailer should be inspected annually for signs of wear or deformations.

## LEAF SUSPENSION

The leaf suspension springs and associated components (Figure 57) should be visually inspected every 6,000 miles for signs of excessive wear, elongation of bolt holes, and loosening of fasteners. Replace all damaged parts (suspension) immediately.

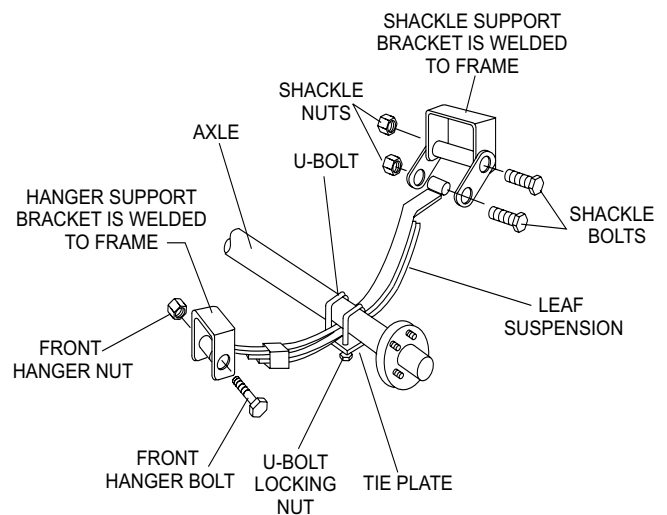

**Figure 57. Leaf Suspension Components**

### **!** DANGER

Worn or broken suspension parts can cause loss of control, damage to equipment and severe bodily injury, even death!

Check suspension regularly.

# TRAILER GUIDELINES

---

The following guidelines are intended to assist the operator in the operation and handling of a trailer.

Safety precautions should be followed at all times when operating a trailer. Failure to read, understand and follow the safety guidelines could result in injury to yourself and others. Loss of control of the trailer or tow vehicle can result in death or serious injury.

## COMMON CAUSES FOR LOSS OF TRAILER

- Driving too fast for the conditions (maximum speed when towing a trailer is 55 mph).
- Overloading the trailer or loading the trailer unevenly.
- Trailer improperly coupled to the hitch.
- No braking on trailer.
- Not maintaining proper tire pressure.
- Not keeping lug nuts tight.
- Not properly maintaining the trailer structure.
- Ensure machine is towed level to tow vehicle.

## TRAILER TOWING GUIDELINES

- Recheck the load tiedowns to make sure the load will not shift during towing.
- Before towing, check coupling, safety chain, safety brake, tires, wheels and lights.
- Check the lug nuts or bolts for tightness.
- Check coupler tightness after towing 50 miles.
- Use your mirrors to verify that you have room to change lanes or pull into traffic.
- Use your turn signals well in advance. Allow plenty of stopping space for your trailer and tow vehicle.
- Allow plenty of stopping space for your trailer and tow vehicle.
- **DO NOT** drive so fast that the trailer begins to sway due to speed.
- Allow plenty of room for passing. A rule of thumb is that the passing distance with a trailer is 4 times the passing distance without the trailer.

- Shift your automatic transmission into a lower gear for city driving.
- **ALWAYS** use lower gears for climbing and descending grades.
- **DO NOT** ride the brakes while descending grades, they may get so hot that they stop working. Then you will potentially have a runaway tow vehicle and trailer.
- To conserve fuel, don't use full throttle to climb a hill. Instead, build speed on the approach.
- Slow down for bumps in the road. Take your foot off the brake when crossing the bump.
- **DO NOT** brake while in a curve unless absolutely necessary. Instead, slow down before you enter the curve and power through the curve. This way, the towing vehicle remains in charge.
- **DO NOT** apply the brakes to correct extreme trailer swaying. Continued pulling of the trailer, and even slight acceleration, will provide a stabilizing force.
- Anticipate the trailer "swaying." Swaying is the trailer reaction to the air pressure wave caused by passing trucks and buses. Continued pulling of the trailer provides a stabilizing force to correct swaying. **DO NOT** apply the brakes to correct trailer swaying.
- Use lower gear when driving down steep or long grades. Use the engine and transmission as a brake. Do not ride the brakes, as they can overheat and become ineffective.
- Be aware of your trailer height, especially when approaching roofed areas and around trees.
- Make regular stops, about once each hour. Confirm that:
  - Coupler is secure to the hitch and is locked.
  - Electrical connectors are secure.
  - There is appropriate slack in the safety chains.
  - There is appropriate slack in the breakaway switch pullpin cable.
  - Tires are not visibly low on pressure.

# TRAILER GUIDELINES

## DRIVING CONDITIONS

When towing a trailer, you will have decreased acceleration, increased stopping distance, and increased turning radius (which means you must make wider turns to keep from hitting curbs, vehicles, and anything else that is on the inside corner). In addition, you will need a longer distance to pass, due to slower acceleration and increased length.

- Be alert for slippery conditions. You are more likely to be affected by slippery road surfaces when driving a tow vehicle with a trailer, than driving a tow vehicle without a trailer.
- Check rearview mirrors frequently to observe the trailer and traffic.
- **NEVER** drive faster than what is safe.

### **WARNING**

Driving too fast for severe road conditions can result in loss of control and cause death or serious injury.

Decrease your speed as road, weather, and lighting conditions deteriorate.

Always check for local trailer tow speed limits in your area.

### **WARNING**

Do not transport people on the trailer. The transport of people puts their lives at risk and may be illegal.

## COUPLING TO THE TOW VEHICLE

Follow all of the safety precautions and instructions in this manual to ensure safety of persons, equipment, and satisfactory life of the trailer. Always use an adequate tow vehicle and hitch. If the vehicle or hitch is not properly selected and matched to the Gross Vehicle Weight Rating (GVWR) of your trailer, you can cause an accident that could lead to death or serious injury.

If you already have a tow vehicle, know your vehicle tow rating and make certain the trailer's rated capacity is less than or equal to the tow vehicle's rated towing capacity. If you already have (or plan to buy) a trailer, make certain that the tow rating of the tow vehicle is equal to or greater than that of the trailer.

The trailer VIN tag contains the critical safety information

for the use of your trailer. Again, be sure your hitch and tow vehicle are rated for the Gross Vehicle Weight Rating of your trailer.

### **WARNING**

Proper selection and condition of the coupler and hitch are essential to safely towing your trailer. A loss of coupling may result in death or serious injury.

- Be sure the hitch load rating is equal to or greater than the load rating of the coupler.
- Be sure the hitch size matches the coupler size.
- Observe the hitch for wear, corrosion and cracks before coupling. Replace worn, corroded or cracked hitch components before coupling the trailer to the tow vehicle.
- Be sure the hitch components are tight before coupling the trailer to the tow vehicle.

### **WARNING**

An improperly coupled trailer can result in death or serious injury.

**DO NOT** move the trailer until:

- The coupler is secured and locked to hitch.
- The safety chains are secured to the tow vehicle.
- The trailer jack(s) are fully retracted.

**DO NOT** tow the trailer on the road until:

- Tires and wheels are checked.
- The trailer brakes are checked.
- The breakaway switch is connected to the tow vehicle.
- The load is secured to the trailer.
- The trailer lights are connected and checked.

### **WARNING**

Use of a hitch with a load rating less than the load rating of the trailer can result in loss of control and may lead to death or serious injury.

Use of a tow vehicle with a towing capacity less than the load rating of the trailer can result in loss of control, and may lead to death or serious injury.

Be sure your hitch and tow vehicle are rated for the Gross Vehicle Weight Rating of your trailer.

# TRAILER GUIDELINES

## INOPERABLE BRAKES, LIGHTS OR MIRRORS

Be sure that the brakes and all of the lights on your trailer are functioning properly before towing your trailer. Check the trailer taillights by turning on your tow vehicle headlights. Check the trailer brake lights by having someone step on the tow vehicle brake pedal while you look at trailer lights. Do the same thing to check the turn signal lights. See Trailer Wiring Diagram section in this manual.

Standard mirrors usually do not provide adequate visibility for viewing traffic to the sides and rear of a towed trailer. You must provide mirrors that allow you to safely observe approaching traffic.

### WARNING

Improper electrical connection between the tow vehicle and the trailer will result in inoperable lights and can lead to collision.

Before each tow, check that the tail lights, brake lights and turn signals work.

## TRAILER TOWING TIPS

Driving a vehicle with a trailer in tow is vastly different from driving the same vehicle without a trailer in tow. Acceleration, maneuverability and braking are all diminished with a trailer in tow.

It takes longer to get up to speed, you need more room to turn and pass, and more distance to stop when towing a trailer. You will need to spend time adjusting to the different feel and maneuverability of the tow vehicle with a loaded trailer.

Because of the significant differences in all aspects of maneuverability when towing a trailer, the hazards and risks of injury are also much greater than when driving without a trailer. You are responsible for keeping your vehicle and trailer in control, and for all the damage that is caused if you lose control of your vehicle and trailer.

As you did when learning to drive an automobile, find an open area with little or no traffic for your first practice trailering. Of course, before you start towing the trailer, you must follow all of the instructions for inspection, testing, loading and coupling. Also, before you start towing, adjust the mirrors so you can see the trailer as well as the area to the rear of it.

Drive slowly at first, 5 mph or so, and turn the wheel to get the feel of how the tow vehicle and trailer combination responds. Next, make some right and left hand turns. Watch in your side mirrors to see how the trailer follows the tow vehicle. Turning with a trailer attached requires more room.

Stop the rig a few times from speeds no greater than 10 mph. If your trailer is equipped with brakes, try using different combinations of trailer brake and tow vehicle brake. Note the effect that the trailer brakes have when they are the only brakes used. When properly adjusted, the trailer brakes will come on just before the tow vehicle brakes.

It will take practice to learn how to back up a tow vehicle with a trailer attached. Take it slow. Before backing up, get out of the tow vehicle and look behind the trailer to make sure that there are no obstacles.

Some drivers place their hands at the bottom of the steering wheel, and while the tow vehicle is in reverse, “think” of the hands as being on the top of the wheel. When the hands move to the right (counterclockwise, as you would do to turn the tow vehicle to the left when moving forward), the rear of the trailer moves to the right. Conversely, rotating the steering wheel clockwise with your hands at the bottom of the wheel will move the rear of the trailer to the left while backing up.

If you are towing a bumper hitch rig, be careful not to allow the trailer to turn too much because it will hit the rear of the tow vehicle. To straighten the rig, either pull forward or turn the steering wheel in the opposite direction.

## TRAILER VIN TAG

Figure A below is a sample of the Vehicle Identification Number (VIN) Tag which is typically located on the left front of the trailer. See Figure B for location.

MANUFACTURED BY / FABRIQUE PAR:		DATE:	
GVWR / PNBV	KG ( LB)		
GAWR (EACH AXLE) / PNBRE (CHAQUE ESSIEU)	KG ( LB)	TIRES / PNEUS	
RIMS / JANTE			
COLD INFL. PRESS. / PRESS. DE GONFL. A FROID	KPA (	PSI / LPC	<input checked="" type="checkbox"/> SINGLE <input type="checkbox"/> DUAL
THIS VEHICLE CONFORMS TO ALL APPLICABLE U.S. FEDERAL MOTOR VEHICLE SAFETY STANDARDS IN EFFECT ON THE DATE OF MANUFACTURE SHOWN ABOVE. CE VEHICULE CONFORME A TOUTES LES NORMES QUI SONT APPLICABLES EN VERTU DU REGLEMENT SUR LA SECURITE DES VEHICULES AUTOMOBILES DU CANADA EN VIGUEUR A LA DATE DE SA FABRICATION.			
V.I.N. / N.I.M.:		TYPE / TYPE: TRAILER TRA / REM	FD-306 REV A

Figure A. Vehicle VIN Tag



# TRAILER GUIDELINES

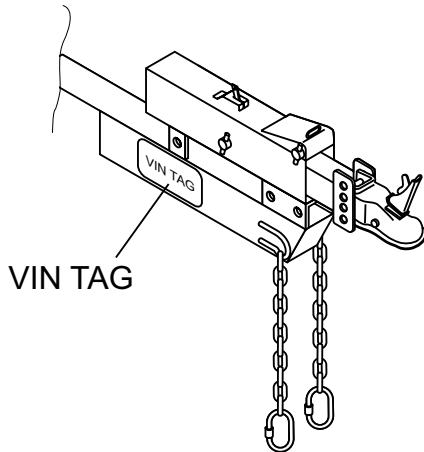

**Figure B. Typical VIN Tag Location**

The trailer VIN Tag contains the following critical safety information for the use of your trailer.

**GAWR:** The maximum gross weight that an axle can support. It is the lowest of axle, wheel, or tire rating.

Usually, the tire or wheel rating is lower than the axle rating, and determines GAWR.

**GVWR:** The maximum allowable gross weight of the trailer and its contents. The gross weight of the trailer includes the weight of the trailer and all of the items within it. GVWR is sometimes referred to as GTWR (Gross Trailer Weight Rating), or MGTW (Maximum Gross Trailer Weight). GVWR, GTWR and MGTW are all the same rating.

The sum total of the GAWR for all trailer axles may be less than the GVWR for the trailer, because some of the trailer load is to be carried by the tow vehicle, rather than by the trailer axle(s). The total weight of the cargo and trailer must not exceed the GVWR, and the load on an axle must not exceed its GAWR.

**PSIC:** The tire pressure (psi) measured when cold.

**VIN:** The Vehicle Identification Number.

**EMPTY WEIGHT:** Some information that comes with the trailer (such as the Manufacturer's Statement of Origin) is not a reliable source for "empty" or "net" weight. The shipping documents list average or standard weights and your trailer may be equipped with options.

To determine the "empty" or "net" weight of your trailer, weigh it on an axle scale. To find the weight of the trailer using an axle scale, you must know the axle weights of your tow vehicle without the trailer coupled. Some of the trailer weight will be transferred from the trailer to the tow vehicle axles, and an axle scale weighs all axles, including the tow vehicle axles.

## TOW VEHICLE

The towing hitch attached to your tow vehicle must have a capacity equal to or greater than the load rating of the trailer you intend to tow. The hitch capacity must also be matched to the tow vehicle capacity. Your vehicle dealer can provide and install the proper hitch on your tow vehicle.

## SUSPENSION SYSTEM

Sway bars, shock absorbers, heavy duty springs, heavy duty tires and other suspension components may be required to sufficiently tow the trailer and pump.

## BRAKE CONTROLLER

For trailers equipped with electric brakes, the electric brake controller is part of the tow vehicle and is essential in the operation of the electric brakes on the trailer. The brake controller is not the same as the safety breakaway brake system that may be equipped on the trailer.

## SIDE VIEW MIRRORS

The size of the trailer that is being towed and your state law regulations determine the size of the mirrors. However, some states prohibit extended mirrors on a tow vehicle, except while a trailer is actually being towed. In this situation, detachable extended mirrors are necessary. Check with your dealer or the appropriate state agency for mirror requirements.

## HEAVY DUTY FLASHER

A Heavy Duty Flasher is an electrical component that may be required when your trailer turn signal lights are attached to the tow vehicle flasher circuit.

## ELECTRICAL CONNECTOR

An Electrical Connector connects the light and brake systems on the trailer to the light and brake controls on the towing vehicle.

# TRAILER GUIDELINES

## EMERGENCY FLARES AND TRIANGLE REFLECTORS

It is wise to carry these warning devices even if you are not towing a trailer. It is particularly important to have these when towing a trailer because the hazard flashers of your towing vehicle will not operate for as long a period of time when the battery is running both the trailer lights and tow vehicle lights.

## SAFETY CHAINS

If the coupler connection comes loose, the safety chains can keep the trailer attached to the tow vehicle. With properly rigged safety chains, it is possible to keep the tongue of the trailer from digging into the road pavement, even if the coupler-to-hitch connection comes apart.

## TRAILER LIGHTING AND BRAKING CONNECTOR

A device that connects electrical power from the tow vehicle to the trailer. Electricity is used to turn on brake lights, running lights, and turn signals as required. In addition, if your trailer has a separate braking system, the electrical connector will also supply power to the brakes from the tow vehicle.

## BREAKAWAY SYSTEM

If the trailer coupler connection comes loose, the breakaway system can actuate emergency hydraulic brakes depending on the type of actuator on the trailer. The breakaway cable must be rigged to the tow vehicle with appropriate slack that will activate the system if the coupler connection comes loose.

## JACKSTAND

A device on the trailer that is used to raise and lower the coupler. The jack is sometimes called the “landing gear” or the “tongue jack”.

## COUPLER TYPES

Two types of coupler used with the trailer are discussed below.

- Ball Hitch Coupler
- Pintel Eye Coupler

## BALL HITCH COUPLER

A ball hitch coupler (Figure C) connects to a ball that is located on or under the rear bumper of tow vehicle. This system of coupling a trailer to a tow vehicle is sometimes referred to as “bumper pull.”

A ball hitch trailer may be fitted with a tongue jack that can raise and lower the coupler. The tongue jack is mounted to the A-frame (front or tongue) part of the trailer. By rotating the jack handle clockwise, the jack will extend and raise the tongue of the trailer.

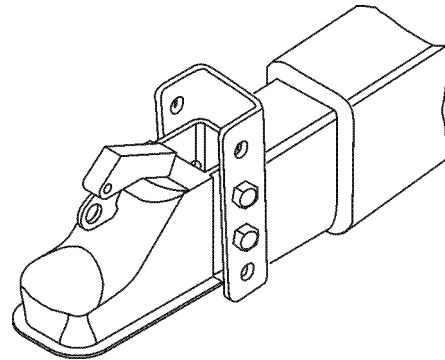

**Figure C. Ball Hitch Coupler**

Before each tow, coat the ball with a thin layer of automotive bearing grease to reduce wear and ensure proper operation. Check the locking device that secures the coupler to the ball for proper operation.

If you see or feel evidence of wear, such as flat spots, deformations, pitting or corrosion, on the ball or coupler, immediately have your dealer inspect them to determine the proper action to prevent possible failure of the ball and coupler system. All bent or broken coupler parts must be replaced before towing the trailer.

The coupler handle lever must be able to rotate freely and automatically snap into the latched position. Oil the pivot points, sliding surfaces, and spring ends with SAE 30W motor oil. Keep the ball socket and latch mechanism clean. Dirt or contamination can prevent proper operation of the latching mechanism.

The load rating of the coupler and the necessary ball size are listed on the trailer tongue. You must provide a hitch and ball for your tow vehicle where the load rating of the hitch and ball is equal to or greater than that of your trailer.

Also, the ball size must be the same as the coupler size. If the hitch ball is too small, too large, is underrated, is loose



# TRAILER GUIDELINES

or is worn, the trailer can come loose from the tow vehicle and may cause death or serious injury.

THE TOW VEHICLE, HITCH AND BALL MUST HAVE A RATED TOWING CAPACITY EQUAL TO OR GREATER THAN THE TRAILER **Gross Vehicle Weight Rating (GVWR)**. IT IS ESSENTIAL THAT THE HITCH BALL BE OF THE SAME SIZE AS THE COUPLER.

The ball size and load rating (capacity) are marked on the ball. Hitch capacity is marked on the hitch.

## **WARNING**

Coupler-to-hitch mismatch can result in uncoupling, leading to death or serious injury.

Be sure the **LOAD RATING** of the hitch ball is equal or greater than the load rating of the coupler.

Be sure the **SIZE** of the hitch ball matches the size of the ball coupler.

## **WARNING**

A worn, cracked or corroded hitch ball can fail while towing and may result in death or serious injury.

Before coupling trailer, inspect the hitch ball for wear, corrosion and cracks.

Replace worn or damaged hitch ball.

## **WARNING**

A loose hitchball nut can result in uncoupling, leading to death or serious injury.

Be sure the hitch ball is tight to the hitch before coupling the trailer.

- Rock the ball to make sure it is tightened to the hitch, and visually check that the hitch ball nut is solid against the lock washer and hitch frame.
- Wipe the inside and outside of the coupler. Clean and visually inspect it for cracks and deformations. Feel the inside of the coupler for worn spots and pits.
- Be sure the coupler is secured tightly to the tongue of the trailer. All coupler fasteners must be visibly solid against the trailer frame.
- The bottom surface of the coupler must be above the top of the hitch ball. Use the tongue jackstand to support

the trailer tongue. Wood or concrete blocks may also be used.

## **Coupling the Trailer to the Tow Vehicle (Ball Coupler)**

- Lubricate the hitch ball and the inside of the coupler with a thin layer of automotive bearing grease.
- Slowly back up the tow vehicle so that the hitch ball is near or aligned under the coupler.
- Using the jackstand at the front of trailer (tongue), turn the jackstand crank handle to raise the trailer. If the ball coupler does not line up with the hitch ball, adjust the position of the tow vehicle.
- Open the coupler locking mechanism. Ball couplers have a locking mechanism with an internal moving piece and an outside handle. In the open position, the coupler is able to drop fully onto the hitch ball.
- Lower the trailer (Figure D) until the coupler fully engages the hitch ball.

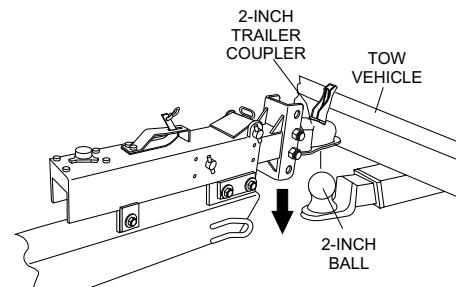

**Figure D. Ball Hitch Coupling Mechanism**

- Engage the coupler locking mechanism. In the engaged position, the locking mechanism securely holds the coupler to the hitch ball.
- Insert a pin or lock through the hole in the locking mechanism.
- Be sure the coupler is all the way on the hitch ball and the locking mechanism is engaged. A properly engaged locking mechanism will allow the coupler to raise the rear of the tow vehicle. Using the trailer jackstand, verify that you can raise the rear of the tow vehicle by 1 inch after the coupler is locked to the hitch.
- Lower the trailer so that its entire tongue weight is held by the hitch.
- Raise the jackstand to a height where it will not interfere with the road.

# TRAILER GUIDELINES

## NOTICE

Overloading can damage the tongue jack. **DO NOT** use the tongue jack to raise the tow vehicle more than one inch.

If the coupler cannot be secured to the hitch ball, do not tow the trailer. Call your dealer for assistance. Lower the trailer so that its entire tongue weight is held by the hitch and continue retracting the jack to its fully retracted position.

## Attaching Safety Chain

Visually inspect the safety chains and hooks for wear or damage. Replace worn or damaged safety chains and hooks before towing.

Attach the safety chains so that they:

- Cross underneath the coupler. See Figure E.

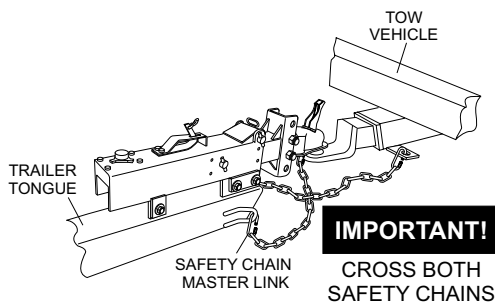

**Figure E. Attaching Safety Chain (Ball Hitch)**

- Loop around a frame member of the tow vehicle or holes provided in the hitch system (**DO NOT** attach them to an interchangeable part of the hitch assembly).
- Have enough slack to permit tight turns, but not be close to the road surface, so if the trailer uncouples, the safety chains can hold the tongue up above the road

## WARNING

Improper rigging of the safety chains can result in loss of control of the trailer and tow vehicle, leading to death or serious injury, if the trailer uncouples from the tow vehicle.

- Fasten chains to frame of tow vehicle. **DO NOT** fasten chains to any part of the hitch unless the hitch has holes or loops specifically for that purpose.
- Cross chains underneath hitch and coupler with enough slack to permit turning and to hold tongue up, if the trailer comes loose.

## Breakaway Brake System

If the coupler or hitch fails, a properly connected and working breakaway brake system (Figure F) will apply the hydraulic brakes on the trailer. The safety chains will keep the tow vehicle attached and as the brakes are applied at the trailer's axles, the trailer/tow vehicle combination will come to a controlled stop.

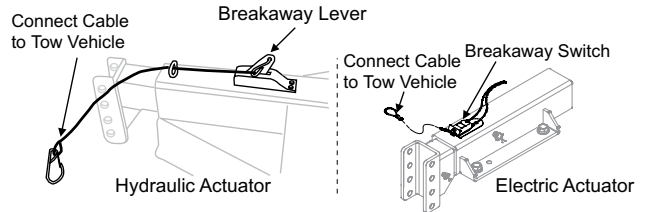

**Figure F. Breakaway Brake System**

## Breakaway Cable Surge Brake System

The breakaway brake system includes a brake cable connected to the tow vehicle on one end and to the emergency brake lever located on the hydraulic actuator on the other end.

## WARNING

- An ineffective breakaway brake system can result in a runaway trailer, leading to death or serious injury, if the coupler or ball hitch fails.
- Connect the breakaway cable to the tow vehicle and **NOT** to the hitch, ball or support.
- Before towing the trailer, test the function of the breakaway brake system. If the breakaway brake system is not working, **DO NOT** tow the trailer. Have it serviced or repaired.

## NOTICE

**DO NOT** tow the trailer with the breakaway brake system **ON** because the brakes will overheat which can result in permanent brake failure.

## NOTICE

Replace the breakaway brake battery (if equipped) at intervals specified by manufacturer.

# TRAILER GUIDELINES

## Connecting Trailer Lights

Connect the trailer lights to the tow vehicle's electrical system using the electric connectors at the front of the trailer (tongue). Refer to the wiring diagram shown in the trailer wiring diagram section of this manual. Before towing the trailer check for the following:

- Running lights (turn on tow vehicle headlights).
- Brake Lights (step on tow vehicle brake pedal).
- Backup Lights (place tow vehicle gear shift in reverse).
- Turn Signals (activate tow vehicle directional signal lever).

### WARNING

Improper electrical connection between the tow vehicle and the trailer will result in inoperable lights and electric brakes, and can lead to collision.

Before each tow:

- Check that the taillights, brake lights and turn signals work.
- Check that the electric brakes work by operating the brake controller inside the tow vehicle.

## Uncoupling the Ball Hitch

Follow these steps to uncouple ball hitch from tow vehicle:

- Block trailer tires to prevent the trailer from rolling, before jacking the trailer up.
- Disconnect the electrical connector.
- Disconnect the breakaway brake switch cable. Promptly replace the pullpin in the switchbox.
- Before extending jackstand, make certain the ground surface below the jackstand foot will support the tongue load.
- Rotate the jackstand handle (or crank) clockwise. This will slowly extend the jack and transfer the weight of the trailer tongue to the jack.

## PINTLE HITCH COUPLER

A pintle eye coupler (Figure G) connects to a pintle-hook hitch that is located on or under the rear bumper of the tow vehicle. This system of coupling a trailer to a tow vehicle is sometimes referred to as a “lunette eye, tow ring or G.I. hitch.”

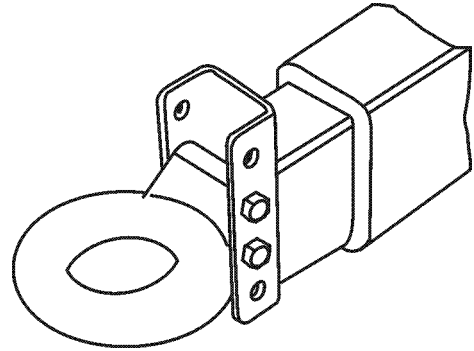

**Figure G. Pintle Hitch Coupler**

A pintle hitch trailer may be fitted with a tongue jackstand that can raise and lower the coupler. The tongue jack is mounted to the A-frame (front or tongue) part of the trailer. By rotating the jack handle clockwise, the jack will extend and raise the tongue of the trailer.

The load rating of the coupler and the necessary pintle hitch size are listed on the trailer tongue. You must provide a pintle hitch and pintle coupler for your tow vehicle, where the load rating of the pintle hitch and pintle coupler is equal to or greater than that of your trailer.

Also, the pintle hitch size must be the same as the pintle coupler size. If the hitch is too small, too large, underrated, loose or worn, the trailer can come loose from the tow vehicle, and may cause death or serious injury.

## Pintle Coupler and Pintle Hook

Before each tow, check the locking device that secures the coupler to the pintle hook assembly.

The pintle hook lever must be able to operate freely and automatically snap into place into the latched position. Lightly oil the pivot points and sliding surfaces with SAE30W motor oil to prevent rust and help ensure proper operation of the latching mechanism.

If you see or feel evidence of wear, such as flat spots, deformations, pitting or corrosion, on the pintle hook or coupler, immediately have your dealer inspect them to determine the proper action to prevent possible failure of

# TRAILER GUIDELINES

the ball and coupler system. All bent or broken coupler parts must be replaced before towing the trailer.

THE TOW VEHICLE, PINTLE HITCH AND PINTLE COUPLER MUST HAVE A RATED TOWING CAPACITY EQUAL TO OR GREATER THAN THE TRAILER **Gross Vehicle Weight Rating (GVWR)**.

IT IS ESSENTIAL THAT THE PINTLE HITCH BE OF THE SAME SIZE AS THE PINTLE COUPLER.

The coupler size and load rating (capacity) are marked on the coupler. Hitch capacity is marked on the hitch.

## WARNING

Coupler-to-hitch mismatch can result in uncoupling, leading to death or serious injury.

Be sure the **LOAD RATING** of the pintle hitch hook is equal or greater than the load rating of the pintle eye coupler.

Be sure the **SIZE** of the pintle hitch hook matches the size of the pintle eye coupler.

## WARNING

A worn, cracked or corroded pintle hitch hook can fail while towing, and may result in death or serious injury.

Before coupling trailer, inspect the pintle hitch hook for wear, corrosion and cracks.

Replace worn or damaged pintle hitch hook.

- Rock the pintle eye coupler to make sure it is secured tightly to the hitch.
- Wipe the inside and outside of the pintle coupler. Clean and inspect it visually for cracks and deformations. Feel the inside of the coupler for worn spots and pits.
- Be sure the coupler is secured tightly to the tongue of the trailer. All coupler fasteners must be visibly solid against the trailer frame.
- Raise the bottom surface of the coupler to be above the top of the pintle hitch hook. Use the tongue jackstand to support the trailer tongue. Wood or concrete blocks may also be used.

## WARNING

A defective pintle hitch not properly fastened can result in uncoupling, leading to death or serious injury.

Be sure the pintle hook is securely tightened to the tow vehicle before coupling the trailer.

## Coupling Trailer to Tow Vehicle (Pintle Coupler)

- Slowly back up the tow vehicle so that the pintle hitch hook is near or aligned under the pintle eye ring coupler.
- Using the jackstand at the front of trailer (tongue), turn the jackstand crank handle to raise the trailer. If the pintle eye coupler does not line up with the pintle hitch hook, adjust the position of the tow vehicle.
- **OPEN** the pintle hook locking mechanism (Figure H). Place the hook inside the eye coupler. **CLOSE** the pintle hook mechanism.

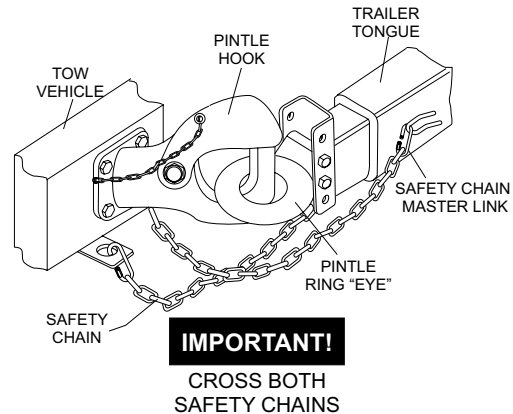

**Figure H. Attaching Safety Chain (Pintle Hitch)**

- Insert a pin or lock through the hole in the locking mechanism.
- Be sure the pintle hook is inserted completely through the eye ring and the locking mechanism is engaged. A properly engaged locking mechanism will allow the coupler to raise the rear of the tow vehicle. Using the trailer jack, test to see that you can raise the rear of the tow vehicle by 1-inch after the coupler is locked to the hitch.
- Lower the trailer so that its entire tongue weight is held by the hitch.
- Raise the jackstand to a height where it will not interfere with the road.

# TRAILER GUIDELINES

## TIRE SAFETY

### Unsafe Tires, Lug Nuts or Wheels

Trailer tires and wheels are more likely to fail than car tires and wheels because they carry a heavier load. Therefore, it is essential to inspect the trailer tires before each tow.

If a tire has a bald spot, bulge, cuts, is showing any cords, or is cracked, replace the tire before towing. If a tire has uneven tread wear, take the trailer to a dealer service center for diagnosis.

Uneven tread wear can be caused by tire imbalance, axle misalignment or incorrect inflation.

Tires with too little tread will not provide adequate tracking on wet roadways and can result in loss of control, leading to death or serious injury.

Improper tire pressure causes an unstable trailer and can result in a tire blowout and loss of control. Therefore, before each tow you must also check the tire pressure. Tire pressure must be checked when tires are cold.

Allow 3 hours cool-down after driving as much as 1 mile at 40 mph before checking tire pressure. Trailer tires will be inflated to higher pressures than passenger vehicle tires.

Since trailer wheels and lug nuts (or bolts) are subjected to greater side loads than automobile wheels, they are more prone to loosen. Before each tow, check to make sure they are tight.

The proper tightness (torque) for lug nuts is listed in the lug nut tightening section of this manual. Use a torque wrench to tighten the lug nuts. If you do not have a torque wrench, use a lug wrench (from your tow vehicle) and tighten the nuts as much as you can. Then have a service garage or trailer dealer tighten the lug nuts to the proper torque.

#### WARNING

Metal creep between the wheel rim and lug nuts will cause rim to loosen and could result in a wheel coming off, leading to death or serious injury.

Tighten lug nuts before each tow.

Lug nuts are also prone to loosen after first being assembled. When driving a new trailer (or after wheels have been remounted), check to make sure they are tight after the first 10, 25 and 50 miles of driving and before each tow thereafter.

Failure to perform this check can result in a wheel parting from the trailer and a crash, leading to death or serious injury.

#### WARNING

Lug nuts are prone to loosen after initial installation, which can lead to death or serious injury.

Check lug nuts for tightness on a new trailer or when wheel(s) have been remounted after the first 10, 25 and 50 miles of driving.

#### WARNING

Improper lug nut torque can cause a wheel parting from the trailer, leading to death or serious injury.

Be sure lug nuts are tight before each tow.

#### WARNING

Improper tire pressure can result in a blowout and loss of control, which can lead to death or serious injury.

Be sure tires are inflated to pressure indicated on side wall before towing trailer.

### Determining Load Limit of Trailer

Determining the load limits of a trailer includes more than understanding the load limits of the tires alone. On all trailers there is a Federal certification/VIN label that is located on the forward half of the left (road) side of the unit. This certification/VIN label will indicate the trailer's Gross Vehicle Weight Rating (GVWR). This is the most weight the fully loaded trailer can weigh. It will also provide the Gross Axle Weight Rating (GAWR). This is the most the axle can weigh.



There is a vehicle placard (Figure I) located in the same location as the certification label described above. This placard provides tire and loading information. In addition, this placard will show a statement regarding maximum cargo capacity.

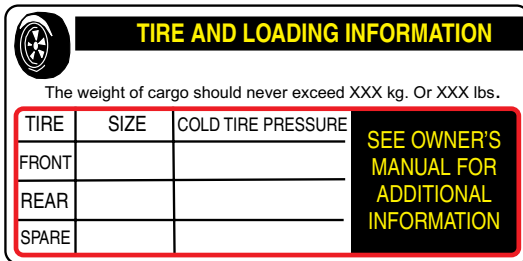

**Figure I. Trailer Tire Placard**

If additional work items (hoses, tools, clamps etc.) are going to be added to the trailer, be sure they are distributed evenly to prevent overloading front to back and side to side. Heavy items should be placed low and as close to the axle positions as reasonable. Too many items on one side may overload a tire.

Excessive loads and/or underinflation cause tire overloading and, as a result, abnormal tire flexing occurs. This situation can generate an excessive amount of heat within the tire. Excessive heat may lead to tire failure. It is the air pressure that enables a tire to support the load, so proper inflation is critical. The proper air pressure may be found on the certification/VIN label and/or on the Tire and Loading Information placard. This value should never exceed the maximum cold inflation pressure stamped on the tire.

Perform the following steps to determine the load limit of your trailer.

### Step 1.

Locate the statement, “The weight of cargo should never exceed XXX kg or XXX lbs.,” on your vehicle’s Tire and Loading Information placard (Figure I). This value equals the available amount of equipment load capacity.

### Step 2.

Determine the weight of the equipment being loaded on the tow vehicle. That weight may not safely exceed the available equipment load capacity. The trailer’s Tire Information Placard is attached adjacent to or near the trailer’s VIN (Certification) label at the left front of the trailer (See Figure I).

## Determining Load Limit of Tow Vehicle

### Step 1.

Locate the statement, “The combined weight of occupants and cargo should never exceed XXX lbs.,” on your vehicle’s placard.

### Step 2.

Determine the combined weight of the driver and passengers who will be riding in your vehicle.

### Step 3.

Subtract the combined weight of the driver and passengers from XXX kilograms or XXX pounds.

### Step 4.

The resulting figure equals the available amount of cargo and luggage capacity. For example, if the “XXX” amount equals 1400 lbs. and there will be five 150 lb. passengers in your vehicle, the amount of available cargo and luggage capacity is 650 lbs. (1400-750 (5 x 150) = 650 lbs.).

### Step 5.

Determine the combined weight of luggage and cargo being loaded on the vehicle. That weight may not safely exceed the available cargo and luggage capacity calculated in Step 4.

If your vehicle will be towing a trailer, load from your trailer will be transferred to your vehicle. Consult the tow vehicle’s manual to determine how this weight transfer reduces the available cargo and luggage capacity of your vehicle.

Studies of tire safety show that maintaining proper tire pressure, observing tire and vehicle load limits (not carrying more weight in your vehicle than your tires or vehicle can safely handle), avoiding road hazards and inspecting tires for cuts, slashes and other irregularities are the most important things you can do to avoid tire failure, such as tread separation or blowout and flat tires. These actions, along with other care and maintenance activities, can also:

- Improve vehicle handling.
- Help protect you and others from avoidable breakdowns and accidents.
- Improve fuel economy.
- Increase the tire life.

# TRAILER GUIDELINES

Use the information contained in this section to make tire safety a regular part of your vehicle maintenance routine. Recognize that the time you spend is minimal compared with the inconvenience and safety consequences of a flat tire or other tire failure.

## TIRE FUNDAMENTALS

Federal law requires tire manufacturers to place standardized information on the sidewall of all tires (Figure J). This information identifies and describes the fundamental characteristics of the tire and also provides a tire identification number for safety standard certification and in case of a recall.

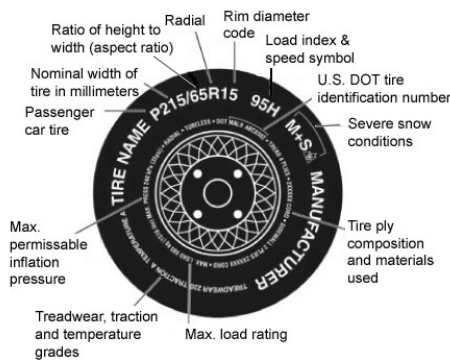

**Figure J. Standard Tire Sidewall Information**

**P:** The “P” indicates the tire is for passenger vehicles.

**Next number:** This three-digit number gives the width in millimeters of the tire from sidewall edge to sidewall edge. In general, the larger the number, the wider the tire.

**Next number:** This two-digit number, known as the aspect ratio, gives the tire’s ratio of height to width. Numbers of 70 or lower indicate a short sidewall for improved steering response and better overall handling on dry pavement.

**P:** The “R” stands for radial. Radial ply construction of tires has been the industry standard for the past 20 years.

**Next number:** This two-digit number is the wheel or rim diameter in inches. If you change your wheel size, you will have to purchase new tires to match the new wheel diameter.

**Next number:** This two- or three-digit number is the tire’s load index. It is a measurement of how much weight each tire can support. You may find this information in your owner’s manual. If not, contact a local tire dealer. *Note:* You may not find this information on all tires because it is not required by law.

**M+S:** The “M+S” or “M/S” indicates that the tire has some mud and snow capability. Most radial tires have these markings; hence, they have some mud and snow capability.

**Speed Rating:** The speed rating denotes the speed at which a tire is designed to be driven for extended periods of time. The ratings range from 99 miles per hour (mph) to 186 mph. These ratings are listed in Table A. *Note:* You may not find this information on all tires because it is not required by law.

Letter Rating	Speed Rating
Q	99 mph
R	106 mph
S	112 mph
T	118 mph
U	124 mph
H	130 mph
V	149 mph
W	168* mph
Y	186* mph

**U.S. DOT Tire Identification Number:** This begins with the letters “DOT” and indicates that the tire meets all federal standards. The next two numbers or letters are the plant code where it was manufactured, and the last four numbers represent the week and year the tire was built. For example, the numbers 3197 means the 31st week of 1997. The other numbers are marketing codes used at the manufacturer’s discretion. This information is used to contact consumers if a tire defect requires a recall.

**Tire Ply Composition and Materials Used:** The number of plies indicates the number of layers of rubber-coated fabric in the tire. In general, the greater the number of plies, the more weight a tire can support. Tire manufacturers also must indicate the materials in the tire, which include steel, nylon, polyester, and others.

**Maximum Load Rating:** This number indicates the maximum load in kilograms and pounds that can be carried by the tire.

**Maximum Permissible Inflation Pressure:** This number is the greatest amount of air pressure that should ever be put in the tire under normal driving conditions.

# TRAILER GUIDELINES

## Uniform Tire Quality Grading Standards (UTQGS)

**Treadwear Number:** This number indicates the tire's wear rate. The higher the treadwear number is, the longer it should take for the tread to wear down. For example, a tire graded 400 should last twice as long as a tire graded 200.

**Traction Letter:** This letter indicates a tire's ability to stop on wet pavement. A higher graded tire should allow you to stop your car on wet roads in a shorter distance than a tire with a lower grade. Traction is graded from highest to lowest as "AA", "A", "B", and "C".

**Temperature Letter:** This letter indicates a tire's resistance to heat. The temperature grade is for a tire that is inflated properly and not overloaded. Excessive speed, underinflation or excessive loading, either separately or in combination, can cause heat build-up and possible tire failure. From highest to lowest, a tire's resistance to heat is graded as "A", "B", or "C".

Refer to Figure K for additional tire information for light trucks.

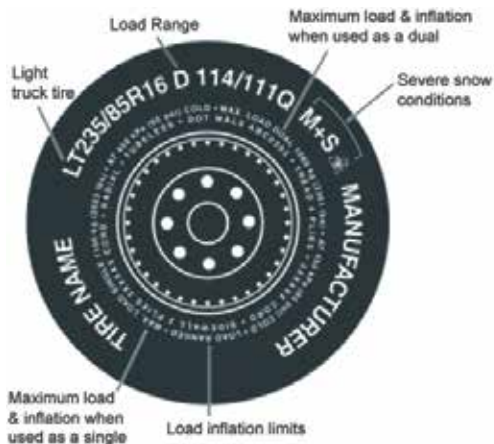

**Figure K. UTQGS Tire Information**

Tires for light trucks have other markings besides those found on the sidewalls of passenger tires.

**LT:** The "LT" indicates the tire is for light trucks or trailers.

**ST:** An "ST" is an indication the tire is for trailer use only.

**Max. Load Dual** kg (lbs) at kPa (psi) Cold: This information indicates the maximum load and tire pressure when the tire is used as a dual, that is, when four tires are put on each rear axle (a total of six or more tires on the vehicle).

**Max. Load Single** kg (lbs) at kPa (psi) Cold: This information indicates the maximum load and tire pressure when the tire is used as a single.

**Load Range:** This information identifies the tire's load-carrying capabilities and its inflation limits.

## Tire Safety Tips

- Slow down if you have to go over a pothole or other object in the road.
- **DO NOT** run over curbs or other foreign objects in the roadway, and try not to strike the curb when parking.
- Check tire inflation pressure weekly during use to insure the maximum tire life and tread wear.
- **DO NOT** bleed air from tires when they are hot.
- Inspect tires for uneven wear patterns on the tread, cracks, foreign objects, or other signs of wear or trauma.
- Remove bits of glass and foreign objects wedged in the tread.
- Make sure your tire valves have valve caps.
- **ALWAYS** check tire pressure on tow vehicle and trailer before towing. Check tire pressure at least once a month.
- **DO NOT** overload tow vehicle. Check the tire information and loading placard for safe allowable tire loading conditions.

## Tire Repair

The proper repair of a punctured tire requires a plug for the hole and a patch for the area inside the tire that surrounds the puncture hole. Punctures through the tread can be repaired if they are not too large, but punctures to the sidewall should not be repaired. Tires must be removed from the rim to be properly inspected before being plugged and patched.







## Replacing Worn or Damaged Tires

Replace the tire before towing the trailer if the tire treads have less than 1/16 inch depth or the telltale bands are visible. Check inflation pressure weekly during use to insure the maximum tire life and tread wear. A bubble, cut or bulge in a side wall can result in a tire blowout. Inspect both side walls of each tire for any bubble, cut or bulge; and replace a damaged tire before towing the trailer.



# TRAILER GUIDELINES

Table B below will help pinpoint the causes and solutions of tire wear problems.

Table B. Tire Wear Troubleshooting			
Wear Pattern		Cause	Solution
	Center Wear	Over inflation.	Adjust pressure to particular load per tire manufacturer.
	Edge Wear	Under inflation.	Adjust pressure to particular load per tire manufacturer.
	Side Wear	Loss of camber or overloading.	Make sure load does not exceed axle rating. Align wheels.
	Toe Wear	Incorrect toe-in.	Align wheels.
	Cupping	Out-of-balance.	Check bearing adjustment and balance tires.
	Flat Spots	Wheel lockup and tire skidding.	Avoid sudden stops when possible and adjust brakes.

**WARNING**



ALWAYS wear safety glasses when removing or installing force fitted parts. **DO NOT** attempt to repair or modify a wheel. **DO NOT** install an inner-tube to correct a leak through through the rim. If the rim is cracked, the air pressure in the inner tube may cause pieces of the rim to explode (break off) with great force and cause serious eye or bodily injury.

## Wheel Rims

If the trailer has been struck, or impacted, on or near the wheels, or if the trailer has struck a curb, inspect the rims for damage (i.e. being out of round); and replace any damaged wheel. Inspect the wheels for damage every year, even if no obvious impact has occurred.

## Wheels, Bearings and Lug Nuts

A loose, worn or damaged wheel bearing is the most common cause of brakes that grab.

To check wheel bearings, jack trailer and check wheels for side-to-side looseness. If the wheels are loose, or spin with a wobble, the bearings must be serviced or replaced. Check inflation pressure weekly during use to insure the maximum tire life and tread wear. Most trailer axles are built with sealed bearings that are not serviceable. Sealed bearings must be replaced as complete units.

### NOTICE

**NEVER** use an pneumatic air gun to tighten wheel lug nuts.

Over-tightening lug nuts will result in breaking the studs or permanently deforming the mounting stud holes in the wheels.

### WARNING

Lug nuts are prone to loosen after initial installation, which can lead to death or serious injury. Check all wheel lug nuts periodically.

## Lug Nut Torque Requirements

It is extremely important to apply and maintain proper wheel mounting torque on the trailer. Be sure to use only the fasteners matched to the cone angle of the wheel. Proper procedure for attachment of the wheels is as follows:

1. Start all wheel lug nuts by hand.
2. Torque all lug nuts in sequence. See Figure L. **DO NOT** torque the wheel lug nuts all the way down. Tighten each lug nut in 3 separate passes as defined by Table C.
3. Check to see if the lug nuts are tight after the first 10, 25 and 50 miles of driving and before each tow thereafter

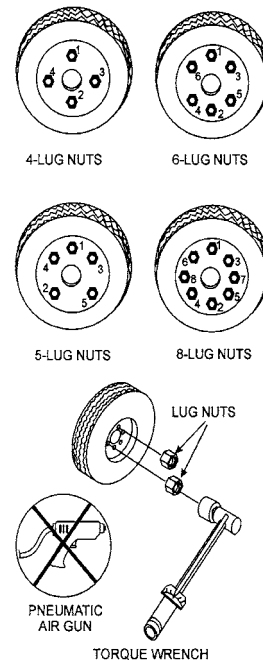

Figure L. Wheel Lug Nuts Tightening Sequence

# TRAILER GUIDELINES

Table C. Tire Torque Requirements			
Wheel Size	First Pass FT-LBS	Second Pass FT-LBS	Third Pass FT-LBS
12"	20-25	35-40	50-65
13"	20-25	35-40	50-65
14"	20-25	50-60	90-120
15"	20-25	50-60	90-120
16"	20-25	50-60	90-120

Replace any broken or burned-out lamps as necessary. Check the wire harness for cuts, fraying or other damage. If it needs replacing, contact your dealer.

**⚠ WARNING**

Improper operating taillights, stoplights and turn signals can cause collisions.

Check all lights before each tow.

## Lights and Signals

Before each tow, check the trailer taillights, stoplights, turn signals and any clearance lights for proper operation.

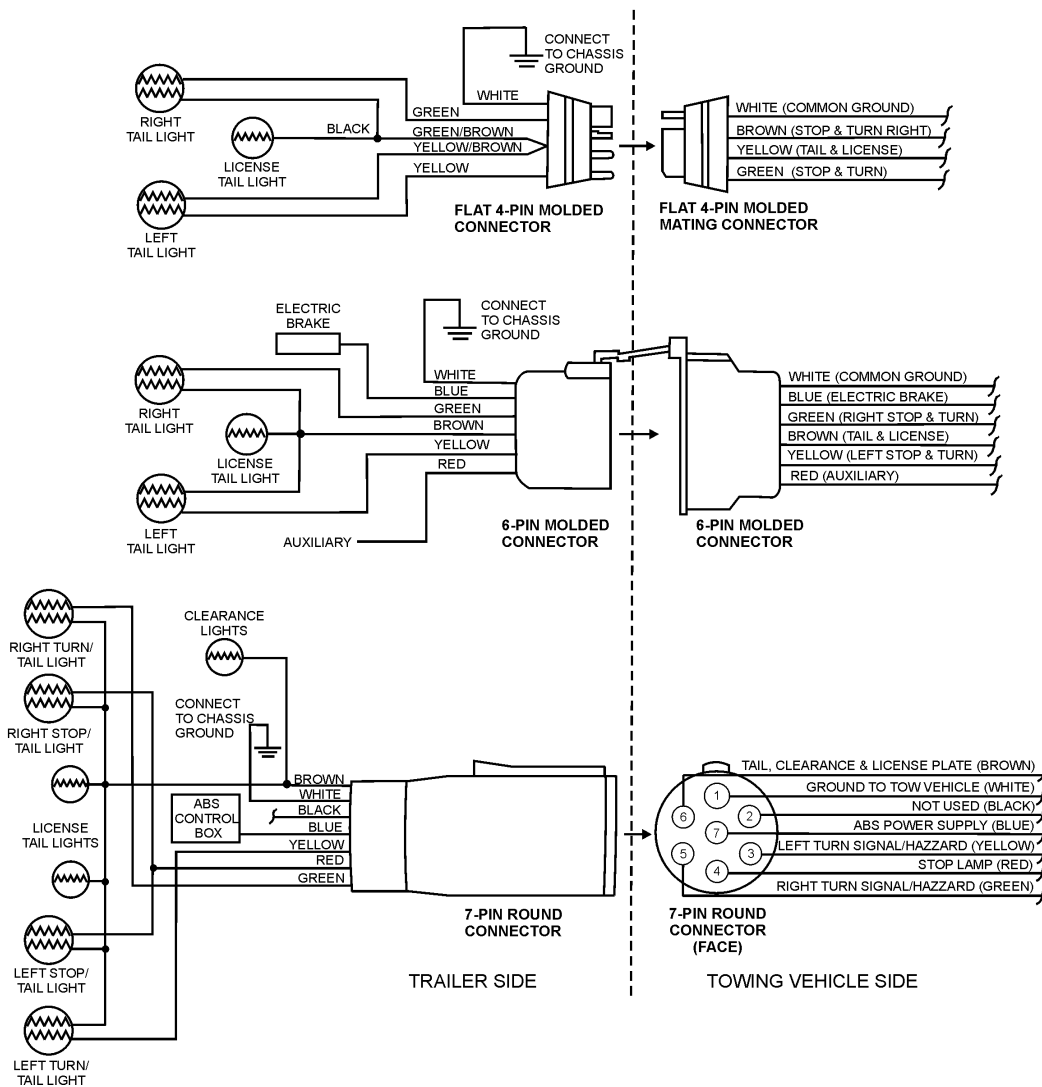

Figure M. Trailer to Tow Vehicle Wiring Diagram



# TROUBLESHOOTING DIAGNOSTIC LAMP

The engine controller of this generator diagnoses problems (faults/errors) that arise from the engine control system and the engine itself.

When any engine faults occur during operation of the generator the **warning lamp** (diagnostic lamp) located on the control panel will turn on. If this conditions occurs please perform immediately the engine fault code diagnostic procedure below.

## ENGINE FAULT CODE DIAGNOSTIC PROCEDURE

1. Remove all loads from the generator and place all circuit breakers in the **OFF** position.
2. Stop the engine, release the retaining screws that secure the control panel to the generator frame.
3. Next, slowly let the control panel fall forward so that the control box is exposed.
4. To start the diagnostic process, place the **diagnostic switch** to the **ON** (Figure 58) position.

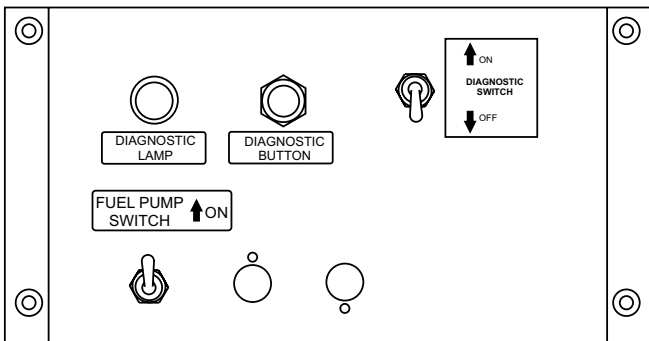

**Figure 58. Diagnostic Panel**

### NOTICE

Make sure to place the diagnostic switch back to the **OFF** position after completing engine fault code diagnostic procedures.

5. Verify that the **diagnostic lamp** is **ON**. This indicates that there is a fault/error in the engine or the engine control system.

6. Push and hold the **diagnostic button** to identify the fault. and verify the following:

- Diagnostic lamp will start blinking with a pattern according to the detected fault code 3 times at a interval rate of 2.4 seconds.
- If two or more faults code are detected the diagnostic lamp will repeat the detected fault codes blinking pattern in ascending order. After all the detected fault codes are shown, the process will repeat starting with the first fault code.
- If no fault is detected the diagnostic lamp will blink repeatedly at a interval rate of 2.4 seconds.

### NOTICE

For a complete understanding of error codes and troubleshooting procedures, refer to the enclosed engine instruction manual.

### NOTICE

The diagnostic lamp will indicate the current fault code with the previous fault code in ascending order.

Also when a fault is detected the fault code will automatically be saved as the previous code in the ECM even after the fault has been repaired.

### NOTICE

If a fault occurs while the engine is running the diagnostic lamp will turn on indicating only the current fault. Please note that the fault code (blinking pattern) cannot be shown while the engine is running.

# TROUBLESHOOTING GENERATOR

Practically all breakdowns can be prevented by proper handling and maintenance inspections, but in the event of a breakdown, use Table 16 shown below for diagnosis of the Generator. If the problem cannot be remedied, consult our company's business office or service plant.

<b>Table 16. Generator Troubleshooting</b>		
<b>Symptom</b>	<b>Possible Problem</b>	<b>Solution</b>
No Voltage Output	AC Voltmeter defective?	Check output voltage using a voltmeter.
	Is wiring connection loose?	Check wiring and repair.
	Is AVR defective?	Replace if necessary.
	Defective Rotating Rectifier?	Check and replace.
	Defective Exciter Field?	Check for approximately 19 ohms across J & K on CN1
Low Voltage Output	Is engine speed correct?	Turn engine throttle lever to "High".
	Is wiring connections loose?	Check wiring and repair.
	Defective AVR?	Replace if necessary.
High Voltage Output	Is wiring connections loose?	Check wiring and repair.
	Defective AVR?	Replace if necessary.
Circuit Breaker Tripped	Short Circuit in load?	Check load and repair.
	Over current?	Confirm load requirements and reduce.
	Defective circuit breaker?	Check and replace.
	Over current Relay actuated?	Confirm load requirement and replace.

# TROUBLESHOOTING ENGINE

Troubleshooting (Engine)		
Symptom	Possible Problem	Solution
Engine will not start or start is delayed, although engine can be turned over.	No Fuel reaching injection pump?	Add fuel. Check entire fuel system.
	Defective fuel pump?	Replace fuel pump.
	Fuel filter clogged?	Replace fuel filter and clean tank.
	Faulty fuel supply line?	Replace or repair fuel line.
	Compression too low?	Check piston, cylinder and valves. Adjust or repair per engine repair manual.
	Fuel pump not working correctly?	Repair or replace fuel pump.
	Oil pressure too low?	Check engine oil pressure.
	Low starting temperature limit exceeded?	Comply with cold starting instructions and proper oil viscosity.
	Defective battery?	Charge or replace battery.
	Air or water mixed in fuel system?	Check carefully for loosened fuel line coupling, loose cap nut, etc.
At low temperatures engine will not start.	Engine oil too thick?	Refill engine crankcase with correct type of oil for winter environment.
	Defective battery?	Replace battery.
Engine fires but stops soon as starter is switched off.	Fuel filter blocked?	Replace fuel filter.
	Fuel supply blocked?	Check the entire fuel system.
	Defective fuel pump?	Replace fuel pump.
Engine stops by itself during normal operation.	Fuel tank empty?	Add fuel.
	Fuel filter blocked?	Replace fuel filter.
	Defective fuel pump?	Replace fuel pump.
	Mechanical oil pressure shutdown sensor stops the engine due to low oil?	Add oil. Replace low oil shutdown sensor if necessary.
Low engine power, output and speed.	Fuel tank empty?	Replace fuel filter.
	Fuel filter clogged?	Replace fuel filter.
	Fuel tank venting is inadequate?	Ensure that tank is adequately vented.
	Leaks at pipe unions?	Check threaded pipe unions tape and tighten unions as required.
	Speed control lever does not remain in selected position?	See engine manual for corrective action.
	Engine oil level too full?	Correct engine oil level.
	Injection pump wear?	Use No. 2-D diesel fuel only. Check the fuel injection pump element and delivery valve assembly and replace as necessary.

## TROUBLESHOOTING ENGINE (CONTINUED)

<b>Troubleshooting (Engine) - continued</b>		
<b>Symptom</b>	<b>Possible Problem</b>	<b>Solution</b>
Low engine power output and low speed, black exhaust smoke.	Air filter blocked?	Clean or replace air filter.
	Incorrect valve clearances?	Adjust valves per engine specification.
	Malfunction at injector?	See engine manual.
Engine overheats.	Too much oil in engine crankcase?	Drain off engine oil down to uppermark on dipstick.
	Entire cooling air system contaminated/ blocked?	Clean cooling air system and cooling fin areas.
	Fan belt broken or elongated?	Change belt or adjust belt tension.
	Coolant insufficient?	Replenish coolant.
	Radiator net or radiator fin clogged with dust?	Clean net or fin carefully.
	Fan, radiator, or radiator cap defective?	Replace defective part.
	Thermostat defective?	Check thermostat and replace if necessary.
Head gasket defective or water leakage?	Replace parts.	

# GENERATOR WIRING DIAGRAM

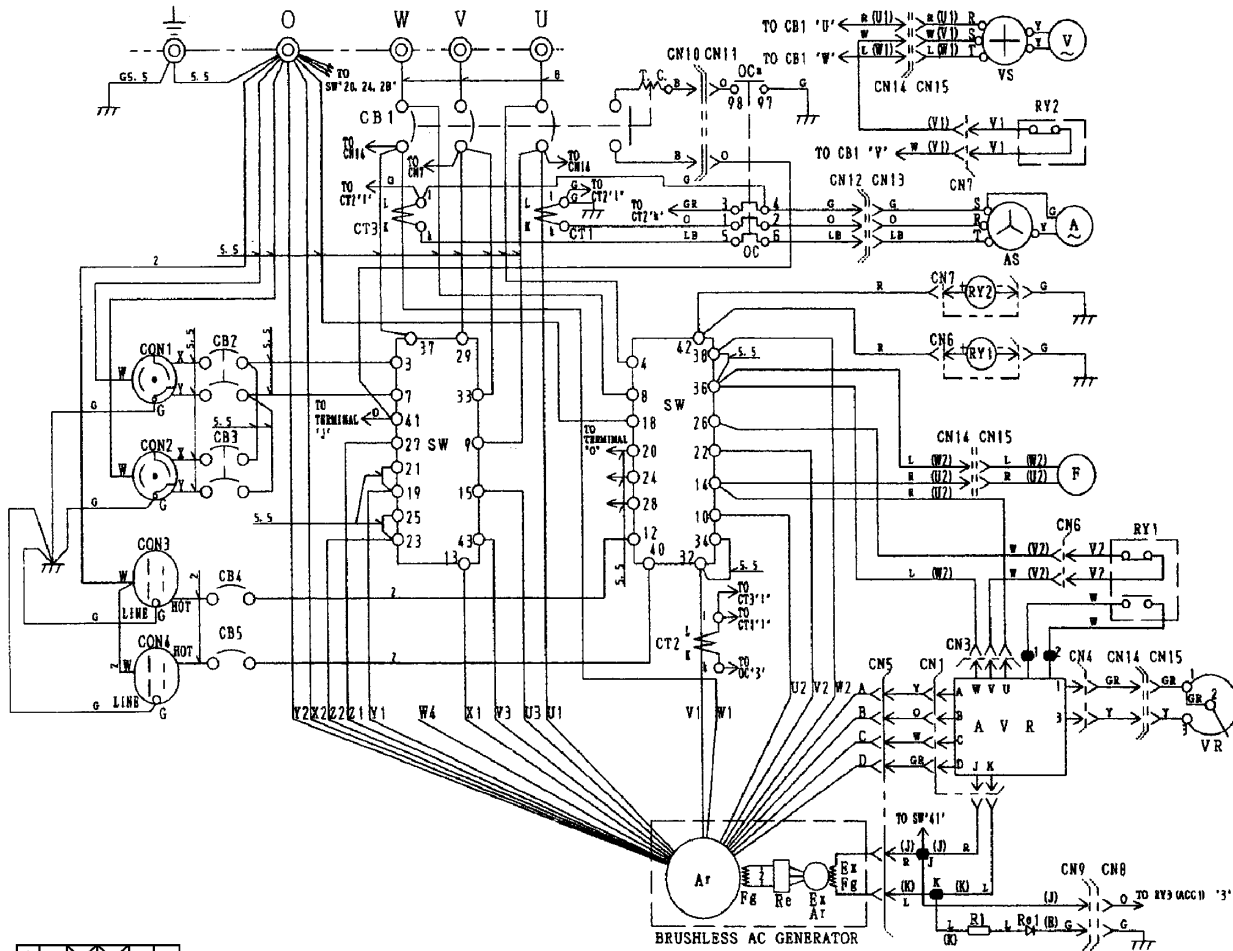

**CONNECTER ARRANGEMENT**  
(WIRING VIEW)

● TERMINAL BOARD

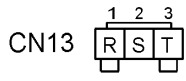
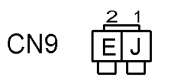
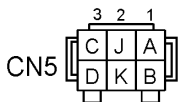
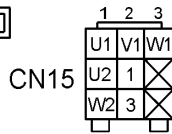
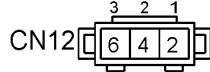
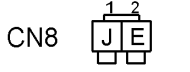
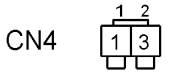
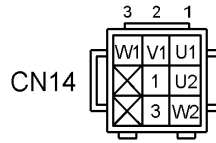
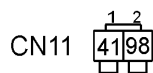
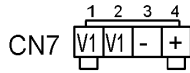
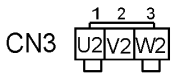
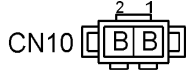
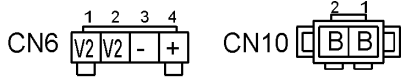
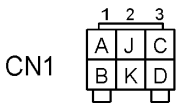

Notice:

1. No designation lead size : 1.25

SYMBOL	DESIGNATION
Ar	MAIN GENERATOR ARMATURE WINDING
Fg	MAIN GENERATOR FIELD WINDING
ExAr	EXCITER ARMATURE WINDING
ExFg	EXCITER FIELD WINDING
Re	RECTIFIER
AVR	AUTOMATIC VOLTAGE REGULATOR
VR	VOLTAGE REGULATOR (RHEOSTAT)
CT 1,2,3	CURRENT TRANSFORMER
AS	CHANGE-OVER SWITCH, AMMETER
A	AC, AMMETER
VS	CHANGE-OVER SWITCH, VOLTMETER
V	AC, VOLTMETER
F	FREQUENCY METER
CB1	CIRCUIT BREAKER 3P 60A
CB2,3	CIRCUIT BREAKER 2P 50A
CB4,5	CIRCUIT BREAKER 1P 20A
CN1,2	RECEPTACLE 250V 50A
CN3,4	RECEPTACLE 125V 20A (GFCI)
OC	OVER CURRENT RELAY
SW	SELECTOR SWITCH
RY1,2	RELAY UNIT
R1	RESISTOR
RE1	RECTIFIER
● J, K, 1, 2	TERMINAL

COLOR CODE			
SYM.	WIRE COLOR	SYM.	WIRE COLOR
B	BLACK	R	RED
L	BLUE	W	WHITE
BR	BROWN	Y	YELLOW
G	GREEN	LB	LIGHT BLUE
GR	GRAY	LG	LIGHT GREEN
V	VIOLET	O	ORANGE
P	PINK		



# ENGINE WIRING DIAGRAM

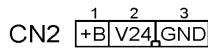
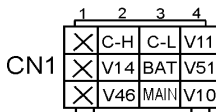
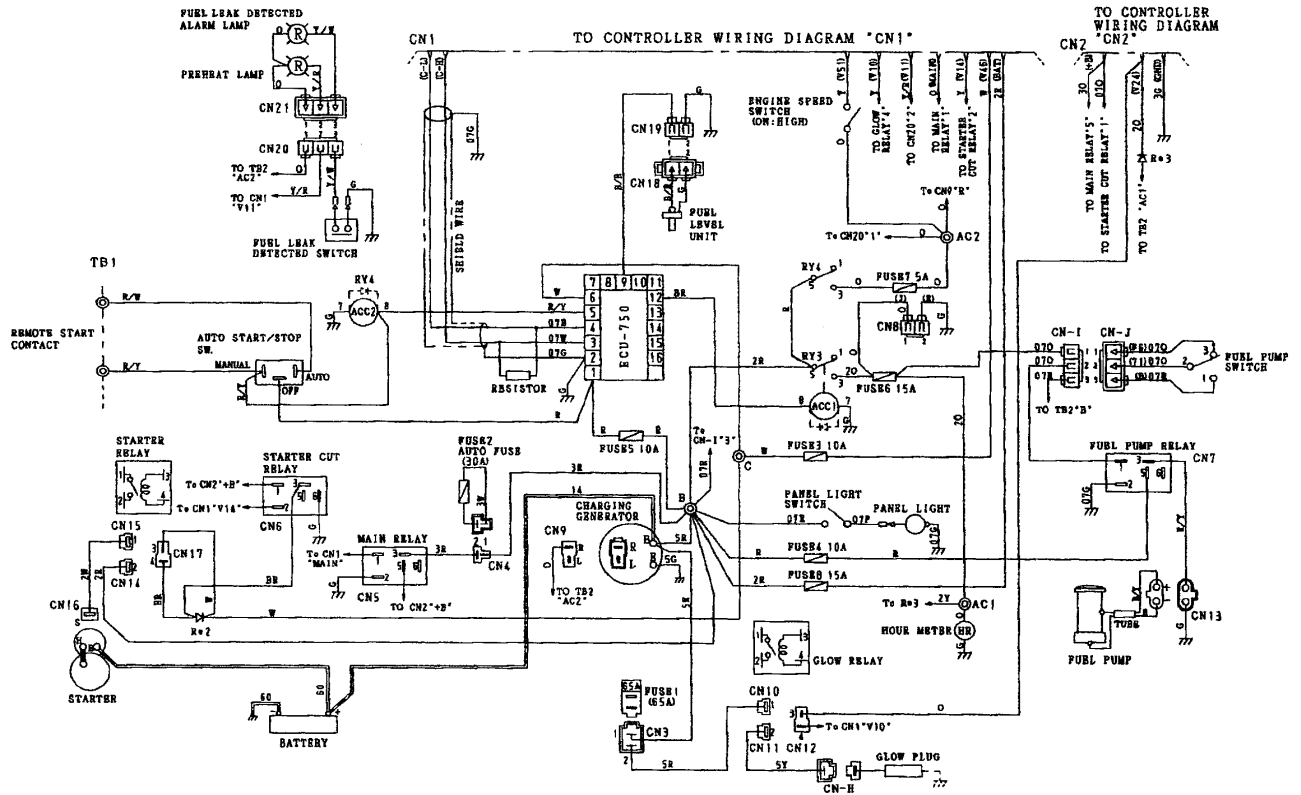

CONNECTER ARRANGEMENT  
(WIRING VIEW)

RELAY INNER CIRCUIT

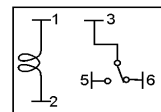

STARTER CUT RELAY  
MAIN RELAY  
FUEL PUMP RELAY

## COLOR CODE

SYM.	WIRE COLOR	SYM.	WIRE COLOR
B	BLACK	R	RED
L	BLUE	W	WHITE
BR	BROWN	Y	YELLOW
G	GREEN	LB	LIGHT BLUE
GR	GRAY	LG	LIGHT GREEN
V	VIOLET	O	ORANGE
P	PINK		

# CONTROLLER WIRING WIRING DIAGRAM

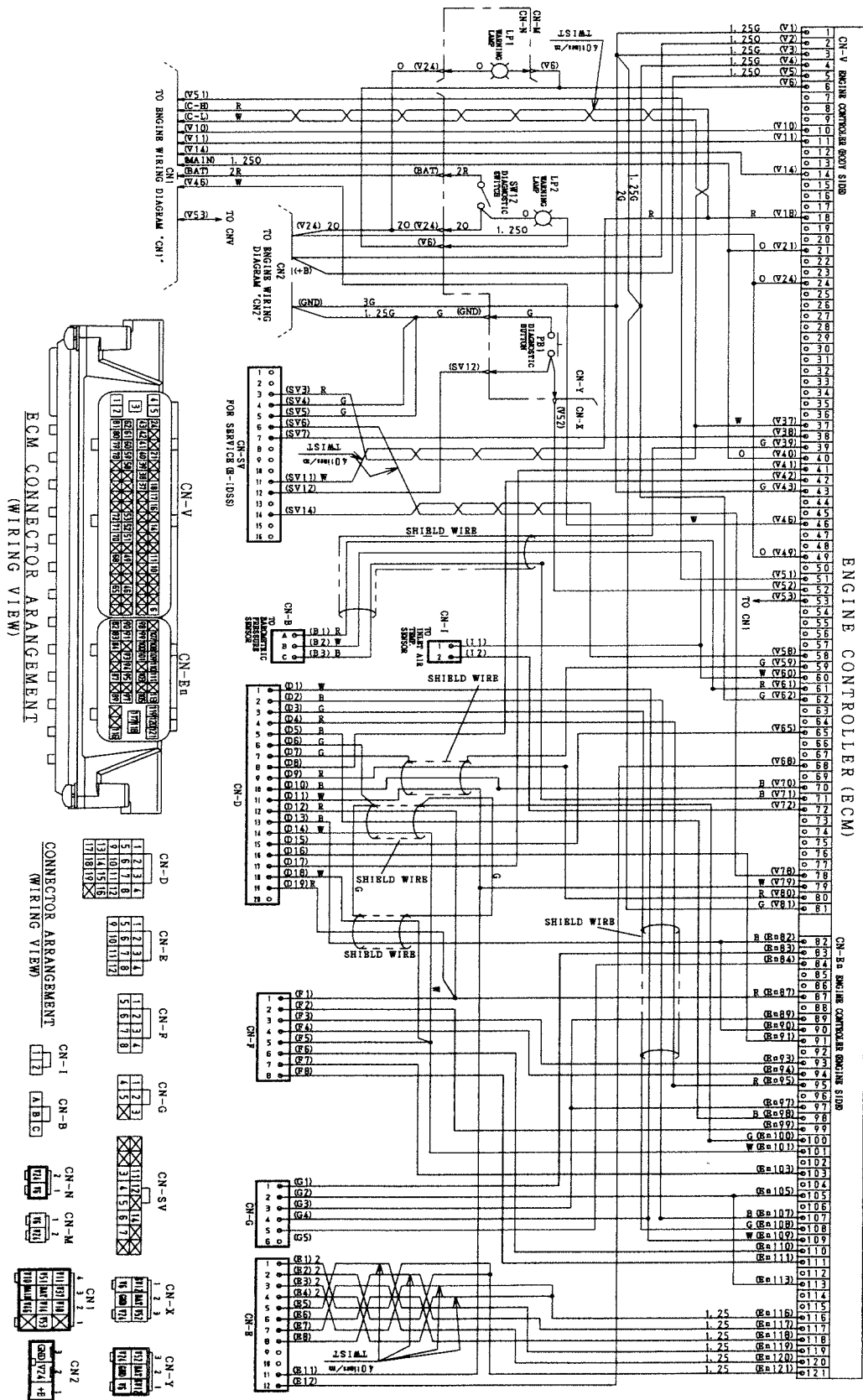



# BATTERY CHARGER WIRING DIAGRAM

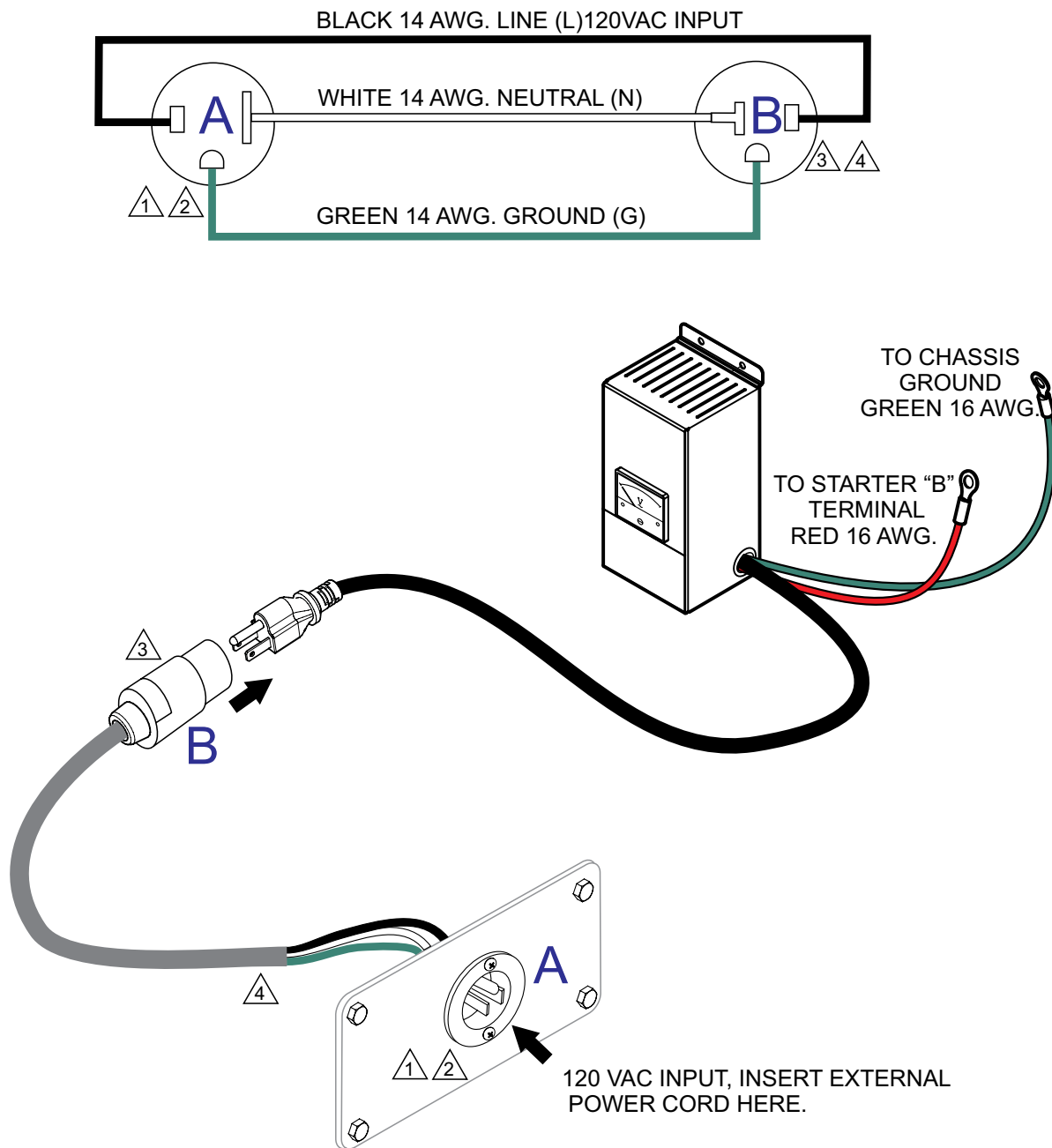

**NOTES:**

- ① NEMA 5-15, 15A, 120 VAC, P/N EE6176 (HBL5278C/HUBBLE RECEPTACLE).
- ② RECEPTACLE IS MOUNTED ON OUTPUT TERMINAL PANEL ASSY.
- ③ 20 AMP, 5-20R RECEPTACLE, P/N EE6131 (HBL5369C/HUBBLE RECEPTACLE).
- ④ CORD, CAROL 3/C 14 AWG., P/N EE56557.

# JACKET WATER HEATER WIRING DIAGRAM

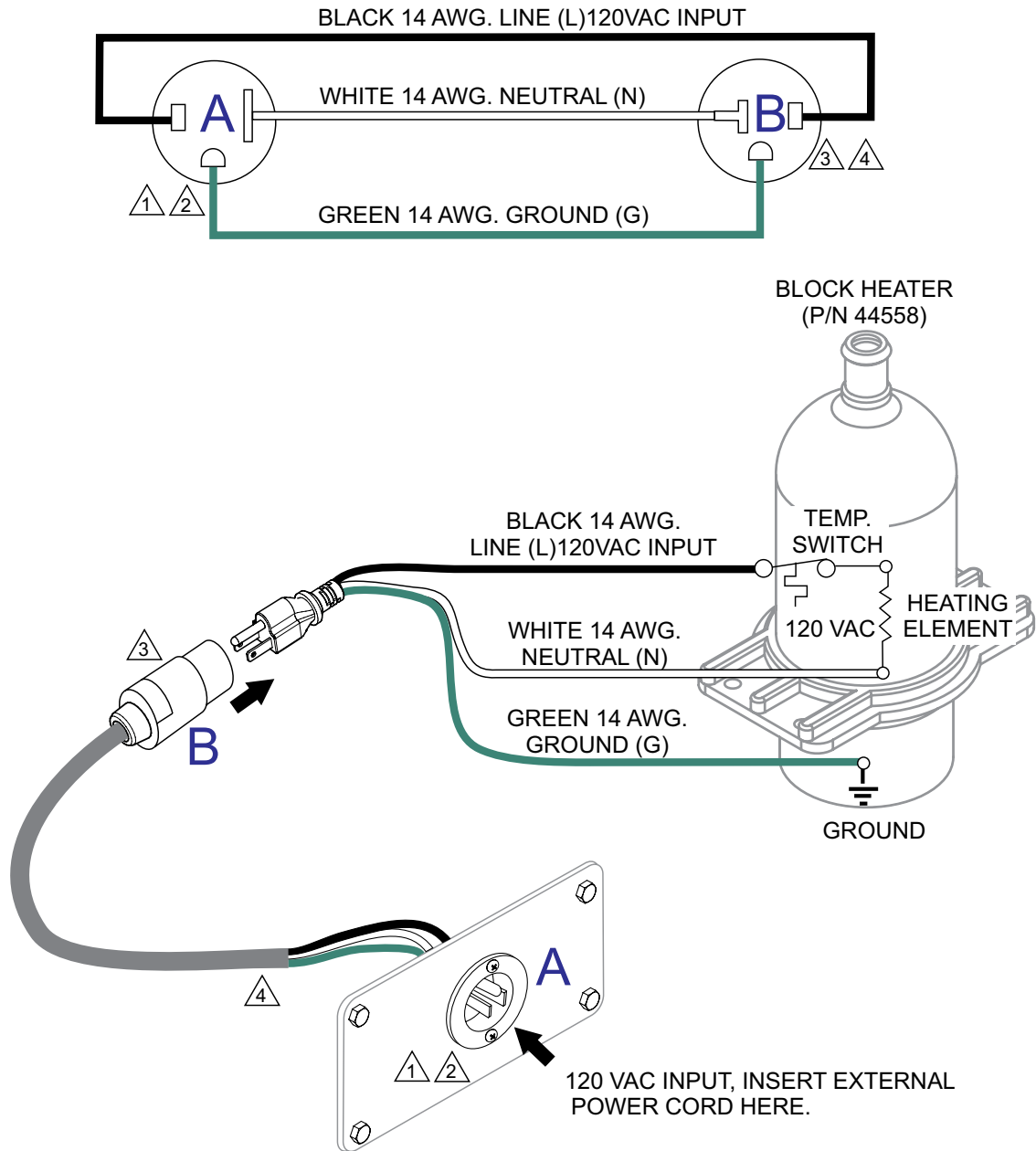

**NOTES:**

- ① NEMA 5-15, 15A, 120 VAC, P/N EE6176 (HBL5278C/HUBBLE RECEPTACLE).
- ② RECEPTACLE IS MOUNTED ON OUTPUT TERMINAL PANEL ASSY.
- ③ 20 AMP, 5-20R RECEPTACLE, P/N EE6131 (HBL5369C/HUBBLE RECEPTACLE).
- ④ CORD, CAROL 3/C 14 AWG., P/N EE56557.

# EXPLANATION OF CODE IN REMARKS COLUMN

The following section explains the different symbols and remarks used in the Parts section of this manual. Use the help numbers found on the back page of the manual if there are any questions.

**NOTICE**

The contents and part numbers listed in the parts section are subject to change **without notice**. Multiquip does not guarantee the availability of the parts listed.

## SAMPLE PARTS LIST

NO.	PART NO.	PART NAME	QTY.	REMARKS
1	12345	BOLT .....	1	INCLUDES ITEMS W/%
2%		WASHER, 1/4 IN. ....		NOT SOLD SEPARATELY
2%	12347	WASHER, 3/8 IN. ...	1	MQ-45T ONLY
3	12348	HOSE .....	A/R	MAKE LOCALLY
4	12349	BEARING .....	1	S/N 2345B AND ABOVE

### NO. Column

**Unique Symbols** — All items with same unique symbol (@, #, +, %, or >) in the number column belong to the same assembly or kit, which is indicated by a note in the “Remarks” column.

**Duplicate Item Numbers** — Duplicate numbers indicate multiple part numbers, which are in effect for the same general item, such as different size saw blade guards in use or a part that has been updated on newer versions of the same machine.

**NOTICE**

When ordering a part that has more than one item number listed, check the remarks column for help in determining the proper part to order.

### PART NO. Column

**Numbers Used** — Part numbers can be indicated by a number, a blank entry, or TBD.

TBD (To Be Determined) is generally used to show a part that has not been assigned a formal part number at the time of publication.

A blank entry generally indicates that the item is not sold separately or is not sold by Multiquip. Other entries will be clarified in the “Remarks” Column.

### QTY. Column

**Numbers Used** — Item quantity can be indicated by a number, a blank entry, or A/R.

A/R (As Required) is generally used for hoses or other parts that are sold in bulk and cut to length.

A blank entry generally indicates that the item is not sold separately. Other entries will be clarified in the “Remarks” Column.

### REMARKS Column

Some of the most common notes found in the “Remarks” Column are listed below. Other additional notes needed to describe the item can also be shown.

**Assembly/Kit** — All items on the parts list with the same unique symbol will be included when this item is purchased.

Indicated by:

“INCLUDES ITEMS W/(unique symbol)”

**Serial Number Break** — Used to list an effective serial number range where a particular part is used.

Indicated by:

“S/N XXXXX AND BELOW”

“S/N XXXX AND ABOVE”

“S/N XXXX TO S/N XXX”

**Specific Model Number Use** — Indicates that the part is used only with the specific model number or model number variant listed. It can also be used to show a part is NOT used on a specific model or model number variant.

Indicated by:

“XXXXX ONLY”

“NOT USED ON XXXX”

**“Make/Obtain Locally”** — Indicates that the part can be purchased at any hardware shop or made out of available items. Examples include battery cables, shims, and certain washers and nuts.

**“Not Sold Separately”** — Indicates that an item cannot be purchased as a separate item and is either part of an assembly/kit that can be purchased, or is not available for sale through Multiquip.

## SUGGESTED SPARE PARTS

### DCA25SSIU4F WHISPERWATT GENERATOR WITH ISUZU 4LE2T DIESEL ENGINE

#### 1 TO 3 UNITS

Qty.	P/N	Description
3.....	2944566410.....	ELEMENT, OIL FILTER
3.....	PMAF25436.....	PRIMARY AIR FILTER (INNER)
3.....	P822769.....	SAFETY AIR FILTER (OUTER)
6.....	8982402790.....	ELEMENT, FUEL FILTER (MAIN)
6.....	8982402800.....	ELEMENT, FUEL FILTER (PRE)
3.....	8981731650.....	KIT, FUEL FEED PUMP
1.....	Y0601802133.....	FUSE, 5A
1.....	Y0601806683.....	FUSE, 8A
3.....	0601802149.....	FUSE, 10A
2.....	0601806671.....	FUSE, 15A
1.....	0601806644.....	FUSE, 30A
1.....	0601806640.....	FUSE, 65A
2.....	0601810277.....	BULB, LAMP
2.....	0601870440.....	CIRCUIT BREAKER 1P 20A
3.....	0601870441.....	CIRCUIT BREAKER 2P 50A
1.....	0605505070.....	CAP, FUEL TANK

#### NOTICE

Part number on this Suggested Spare Parts list may supersede/replace the P/N shown in the text pages of this book.

# GENERATOR ASSY.

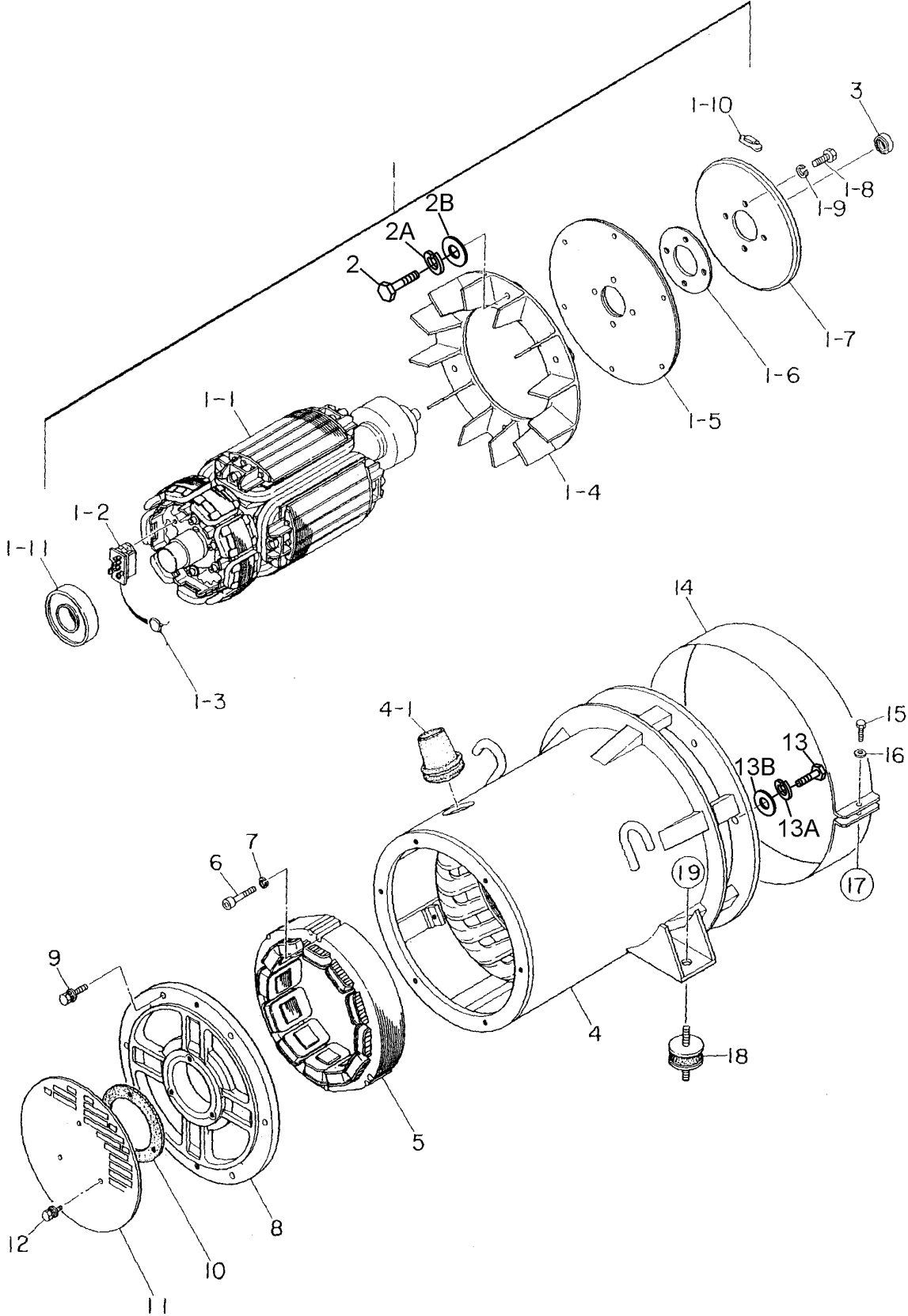



## GENERATOR ASSY.

<u>NO.</u>	<u>PART NO.</u>	<u>PART NAME</u>	<u>QTY.</u>	<u>REMARKS</u>
1	B1110200602	ROTOR ASSY. ....	1.....	INCLUDES ITEMS W/#
1-1#		FIELD ASSY.	1	
1-2#	7961025004	RECTIFIER	1	
1-3#	0601822630	SURGE ABSORBER	1	
1-4#	8001070003	FAN	1	
1-5#	8351611004	COUPLING DISK	2	
1-6#	8351612004	WASHER, COUPLING HUB	1	
1-7#	B1112300003	BALANCING PLATE .....	1.....	PURCHASE ITEM 1-10 AS A SET
1-8#	0105091025	HEX. HEAD BOLT .....	4.....	REPLACES P/N 0010310025
1-9#	030210250	WASHER, LOCK.....	4.....	REPLACES P/N 0042510000
1-10#	0601000209	BALANCING WEIGHT KIT	1	
1-11#	042006308	BEARING.....	1.....	REPLACES P/N 0071906308
2	0010308035	HEX. HEAD BOLT	6	
2A	0040008000	WASHER, LOCK	6	
2B	0401450080	WASHER, FLAT .....	6.....	REPLACES P/N 0041208000
3	0070506803	BEARING	1	
4	B1130201103	STATOR ASSY.	1	
4-1	0845041904	GROMMET	1	
5	B1138000003	FIELD ASSY., EXCITER	1	
6	0016008045	HEX. SOCKET HEAD CAP	3	
7	0042508000	WASHER, LOCK	3	
8	8351315003	END BRACKET	1	
9	0017108035	HEX. HEAD BOLT	6	
10	8351312004	PACKING	1	
11	8351331004	COVER, SUCTION	1	
12	011106015	HEX. HEAD BOLT .....	3.....	REPLACES P/N 0017106015
13	012010030	HEX. HEAD BOLT .....	6.....	REPLACES P/N 0010310030
13A	0040010000	WASHER, LOCK	6	
13B	031110160	WASHER, FLAT .....	6.....	REPLACES P/N 0041210000
14	B0155400204	COVER, FAN	1	
15	0010006030	HEX. HEAD BOLT .....	1.....	REPLACES P/N 0010106030
16	952404470	WASHER, FLAT .....	1.....	REPLACES P/N 0041206000
17	020106050	NUT.....	1.....	REPLACES P/N 0600815000
18	Y0605000409	RUBBER SUSPENSION	2	
19	021112140	SELF-LOCKING NUT .....	2.....	REPLACES P/N 0207010000

# CONTROL BOX 1 ASSY.

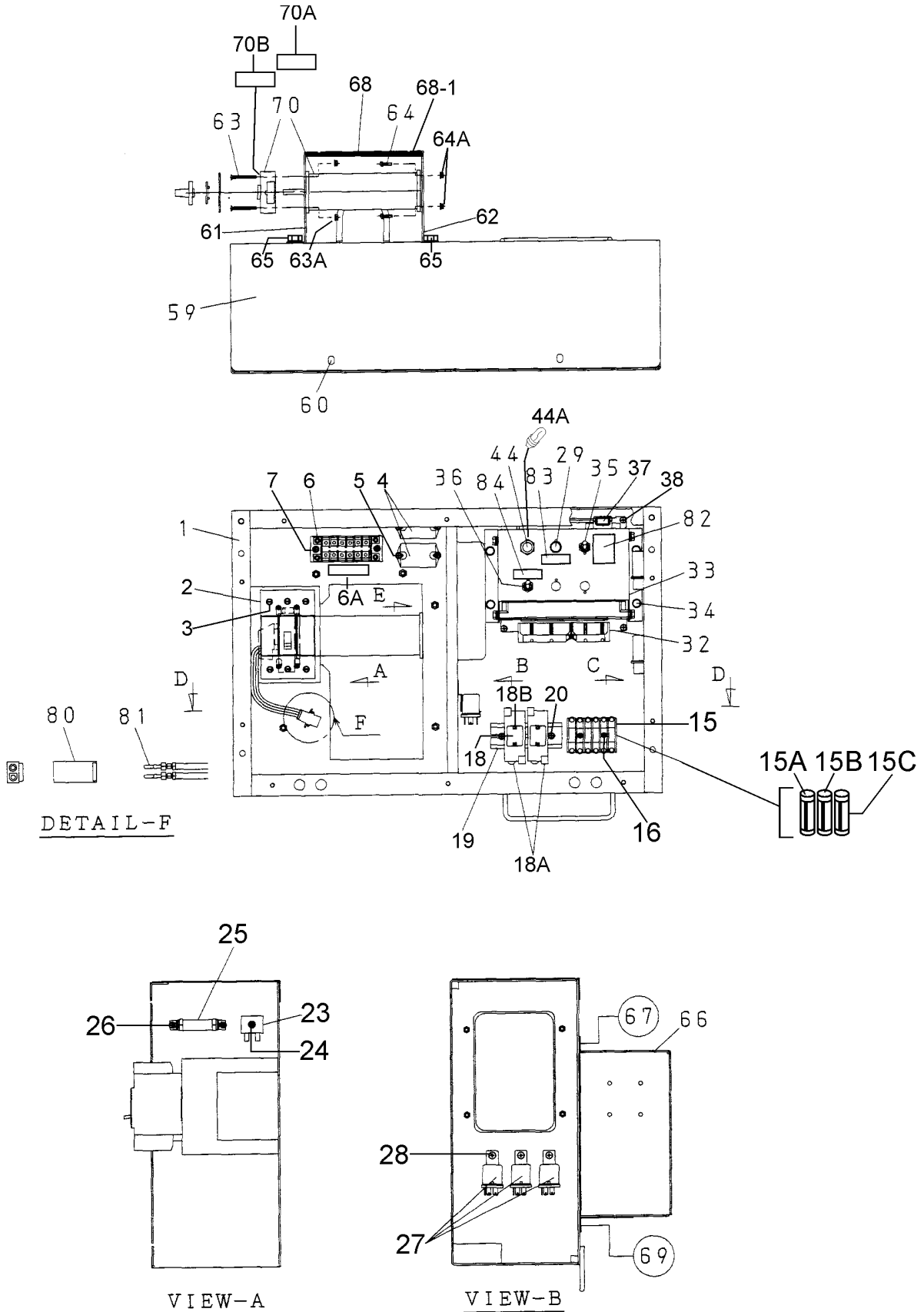

## CONTROL BOX 1 ASSY.

<u>NO.</u>	<u>PART NO.</u>	<u>PART NAME</u>	<u>QTY.</u>	<u>REMARKS</u>
1	M1214000302	CONTROL BOX	1	
2	0601870430	CIRCUIT BREAKER, 3P 60A	1	
3	0021004075	MACHINE SCREW	4	
4	0601823863	RELAY UNIT	2	
5	7538070	MACHINE SCREW .....	4.....	REPLACES P/N 0027104015
6	0601815759	TERMINAL	1	
6A	M9521000004	DECAL: TERMINAL	1	
7	0027104020	MACHINE SCREW	2	
15	Y0601802214	HOLDER, FUSE	1	
15A	0601806671	FUSE, 15A	2	
15B	0601802149	FUSE, 10A	3	
15C	0601802133	FUSE, 5A	1	
16	0027103015	MACHINE SCREW	2	
18	LY2DUS12VDC	RELAY .....	2.....	REPLACES P/N 0601827656
18A	PTF08A	BASE .....	2.....	REPLACES P/N 0601823109
18B	PYCA1	CLIP .....	4.....	REPLACES P/N 0601824400
19	Y0290000100	MOUNTING RAIL	1	
20	7538070	MACHINE SCREW .....	2.....	REPLACES P/N 0027104015
23	0601823240	RECTIFIER	1	
24	0027104020	MACHINE SCREW	1	
25	0601842384	RESISTOR, 20W 50 OHM	1	
26	0027104010	MACHINE SCREW	2	
27	5825500290	RELAY .....	3.....	REPLACES P/N 0602201400
28	0027105010	MACHINE SCREW	3	
29	0601831205	PUSH BUTTON SWITCH	1	
32	8982201570	ENGINE CONTROLLER (ECM) .....	1.....	REPLACES P/N Y0602202699
33	M1214600204	CONTROLLER BRACKET	1	
34	011106015	HEX. HEAD BOLT .....	8.....	REPLACES P/N 0016906015
35	0601830710	DIAGNOSTIC SWITCH	1	
36	0601830762	FUEL PUMP SWITCH	1	
37	8972177780	BAROMETRIC PRESSURE SENSOR .....	1.....	REPLACES P/N 0602130220
38	0027105015	MACHINE SCREW	2	
44	0602103092	ALARM LAMP	1	
44A	0601810277	BULB, 18V	1	
59	M1214500004	CONTROL BOX COVER	1	
60	011106015	HEX. HEAD BOLT .....	4.....	REPLACES P/N 0016906015
61	M1214600804	SWITCH BRACKET	1	
62	M1214600904	SWITCH BRACKET	1	
63	0021104035	MACHINE SCREW	4	
63A	OEMAA8	HEX. NUT .....	4.....	REPLACES P/N 0207004000
64	7538070	MACHINE SCREW .....	4.....	REPLACES P/N 0027104015
64A	OEMAA8	HEX. NUT .....	4.....	REPLACES P/N 0207004000
65	011106015	HEX. HEAD BOLT .....	4.....	REPLACES P/N 0016906015
66	M1214600004	SWITCH COVER	1	
67	011106015	HEX. HEAD BOLT .....	6.....	REPLACES P/N 0016906015
68	M1214600104	SWITCH COVER	1	
68-1	0317700180	WEATHER STRIP	1	

# CONTROL BOX 1 ASSY. (CONTINUED)

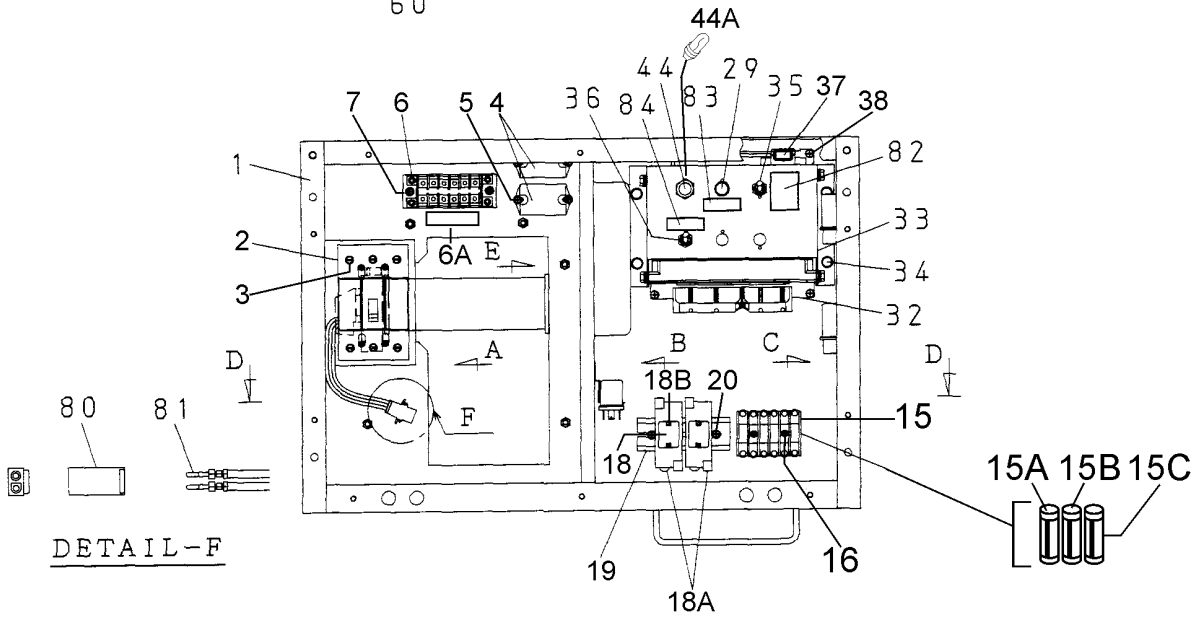
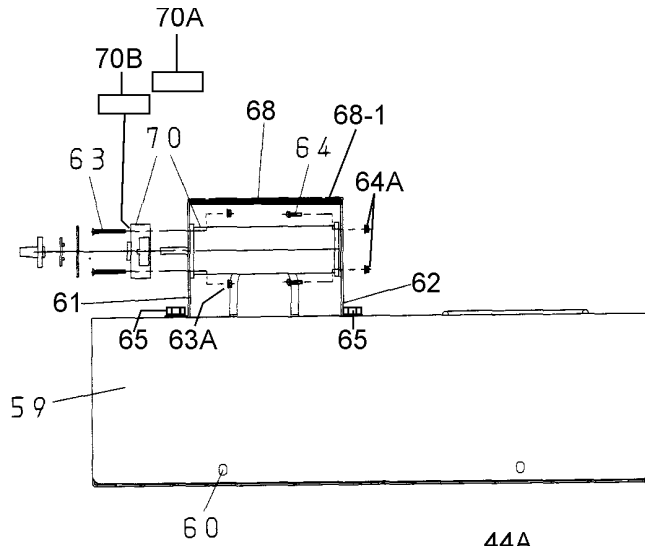

DETAIL-F

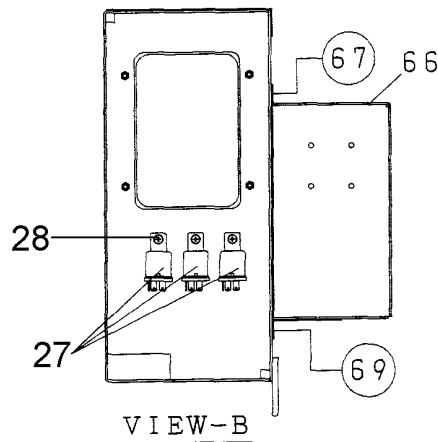
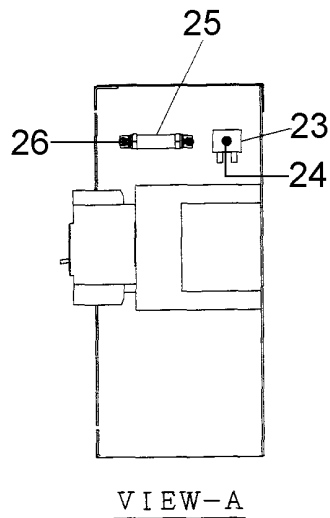

## **CONTROL BOX 1 ASSY. (CONTINUED)**

---

<b><u>NO.</u></b>	<b><u>PART NO.</u></b>	<b><u>PART NAME</u></b>	<b><u>QTY.</u></b>	<b><u>REMARKS</u></b>
69	011106015	HEX. HEAD BOLT .....	4.....	REPLACES P/N 0016906015
70	M1270100004	SELECTOR SWITCH	1	
70A	M1550002704	DECAL: SELECTOR SWITCH NUMBER	1	
70B	M1550002804	DECAL: SELECTOR SWITCH NUMBER	1	
80	0601812626	PLUG	1	
81	0601812712	PINS (MALE)	2	
82	M9520000904	DECAL: DIAGNOSTIC SWITCH	1	
83	M9520001104	DECAL: DIAGNOSTIC BUTTON	1	
84	M9520002104	DECAL: FUEL PUMP SWITCH	1	

# CONTROL BOX 2 ASSY.

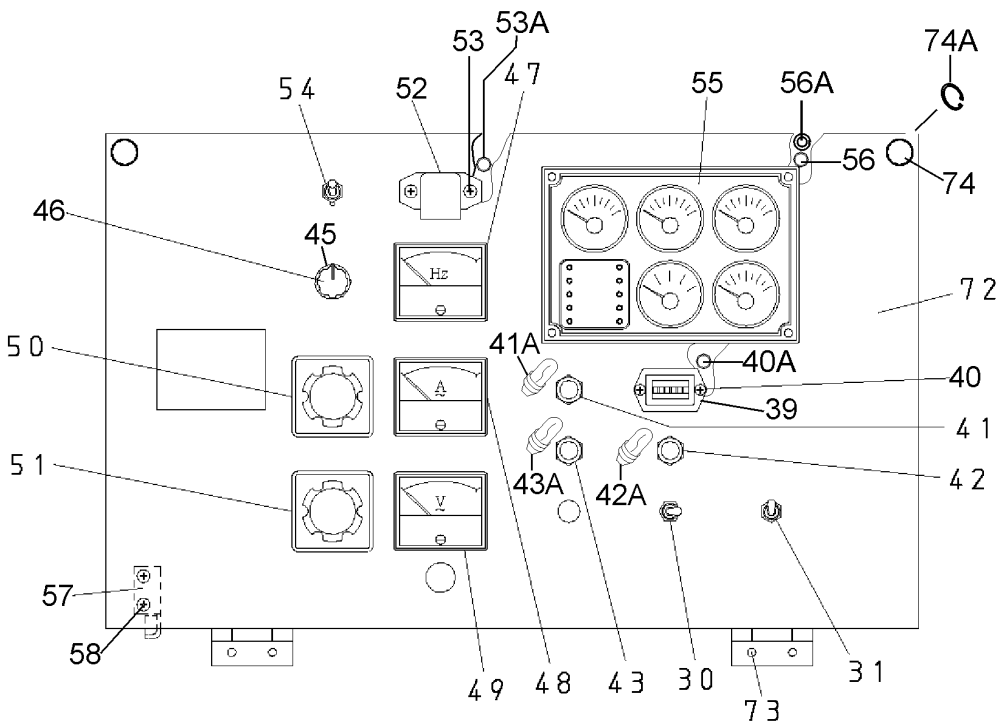
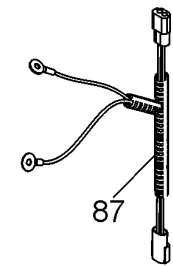
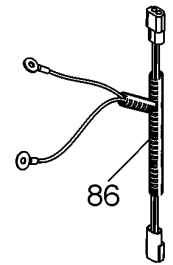
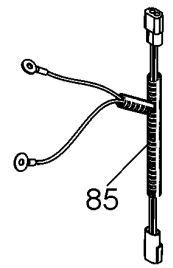
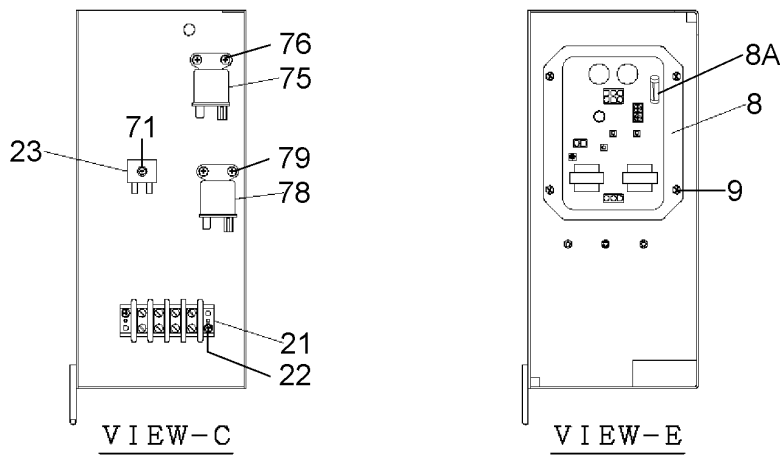
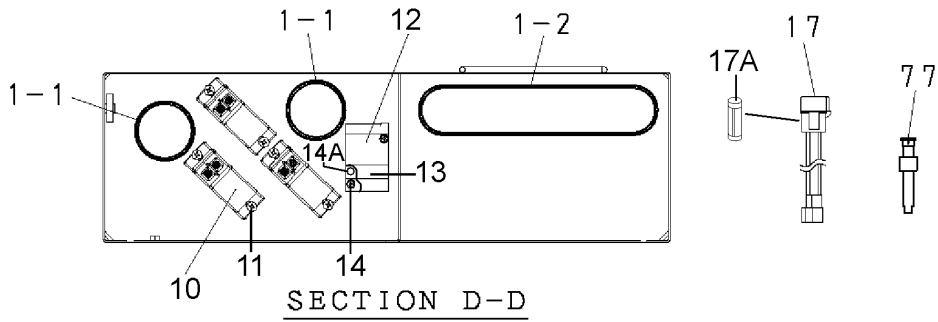

## CONTROL BOX 2 ASSY.

<u>NO.</u>	<u>PART NO.</u>	<u>PART NAME</u>	<u>QTY.</u>	<u>REMARKS</u>
1-1	0330000185	EDGING	2	
1-2	Y0330000550	EDGING	1	
8	0601820608	AUTOMATIC VOLTAGE REGULATOR	1	
8A	Y0601806683	FUSE, 250V 8A	1	
9	0027105015	MACHINE SCREW	4	
10	0601801122	CURRENT TRANSFORMER	3	
11	011808015	MACHINE SCREW .....	6.....	REPLACES P/N 0027106015
12	0601820847	OVER CURRENT RELAY	1	
13	Y0601820848	OVER CURRENT RELAY, 25A	1	
14	0027104020	MACHINE SCREW	2	
14A	OEMAA8	SELF-LOCKING NUT .....	2.....	REPLACES P/N 0207004000
17	C3558201704	HOLDER, FUSE .....	1.....	REPLACES P/N M2357202104
17A	0601806644	FUSE, 30A	1	
21	0601815153	TERMINAL BLOCK	1	
22	7538070	MACHINE SCREW .....	2.....	REPLACES P/N 0027104015
23	0601823240	RECTIFIER	1	
30	82608	AUTO START/STOP SWITCH .....	1.....	REPLACES P/N 0601831340
31	0601830710	ENGINE SPEED SWITCH	1	
39	0601800682	HOUR METER	1	
40	0027103015	MACHINE SCREW	2	
40A	0207003000	SELF-LOCKING NUT	2	
41	0602103092	FUEL LEAK DETECTED ALARM LAMP 18V	1	
41A	0601810277	BULB, 18V	1	
42	0602103092	PREHEAT LAMP 18V	1	
42A	0601810277	BULB, 18V	1	
43	0602103092	WARNING LAMP 18V	1	
43A	0601810277	BULB, 18V	1	
45	0601840073	RHEOSTAT (VR) 2W 1K OHM	1	
46	0601840100	KNOB.....	1.....	REPLACES P/N 0601840121
47	0601807641	FREQUENCY METER, 45-65HZ 240V	1	
48	0601808985	AC AMMETER 0~50A, 0~100A/5A	1	
49	0601806859	AC VOLTMETER 0~600V	1	
50	0601801040	CHANGE-OVER SWITCH, AMMETER	1	
51	0601801041	CHANGE-OVER SWITCH, VOLTMETER	1	
52	Y0601810170	PANEL LIGHT 12V	1	
53	0027104020	MACHINE SCREW	2	
53A	OEMAA8	SELF-LOCKING NUT .....	2.....	REPLACES P/N 0207004000
54	0601830710	PANEL LIGHT SWITCH	1	
55	Y0602202653	CONTROLLER	1	
56	Y0206707000	HEX. NUT	4	
56A	Y0044807000	WASHER, LOCK	4	
57	M1223100104	STOPPER	1	
58	0027105010	MACHINE SCREW	2	

# CONTROL BOX 2 ASSY. (CONTINUED)

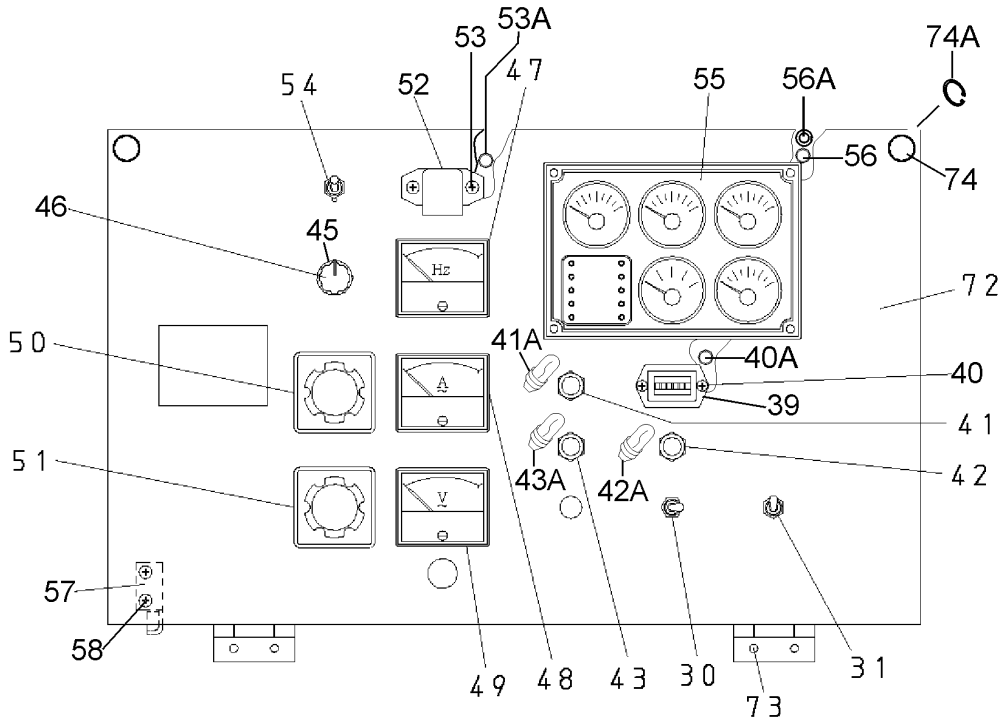
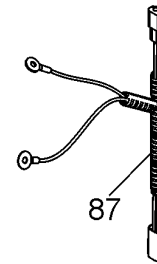
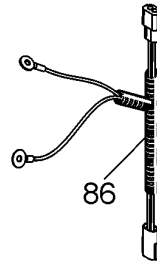
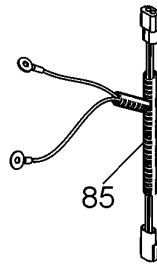
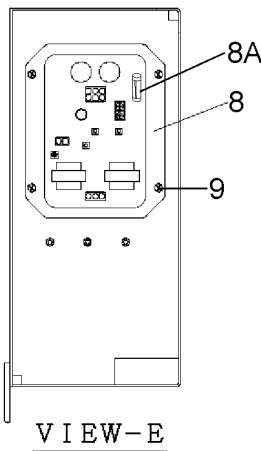
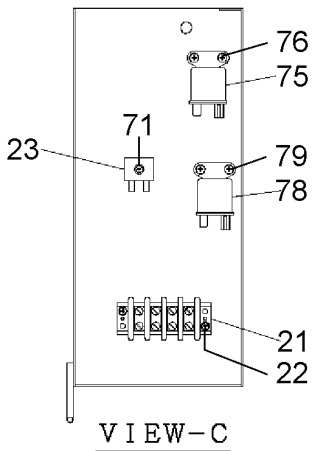
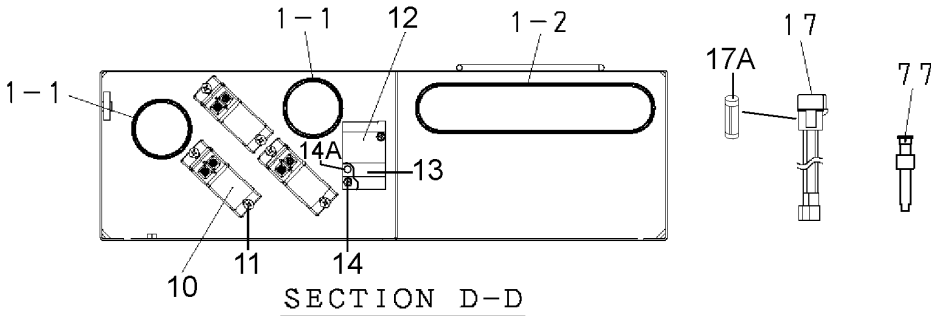



## **CONTROL BOX 2 ASSY. (CONTINUED)**

---

<b><u>NO.</u></b>	<b><u>PART NO.</u></b>	<b><u>PART NAME</u></b>	<b><u>QTY.</u></b>	<b><u>REMARKS</u></b>
71	0027104030	MACHINE SCREW	1	
72	M1224000103	CONTROL PANEL	1	
73	0027105010	MACHINE SCREW	4	
74	M9220100004	SET SCREW	2	
74A	0080200007	E-SNAP RING	2	
75	8944001061	RELAY, STARTER.....	1	REPLACES P/N 0602202502
76	0027105010	MACHINE SCREW	2	
77	0601806640	FUSE, 65A	1	
78	8970119490	GLOW PLUG RELAY.....	1	REPLACES P/N 0602202685
79	0027105010	MACHINE SCREW	2	
85	M1247700604	WIRE HARNESS, GENERATOR	1	
86	M1358200202	WIRE HARNESS, ENGINE	1	
87	M1358200302	WIRE HARNESS, CONTROLLER	1	

# ENGINE AND RADIATOR ASSY.

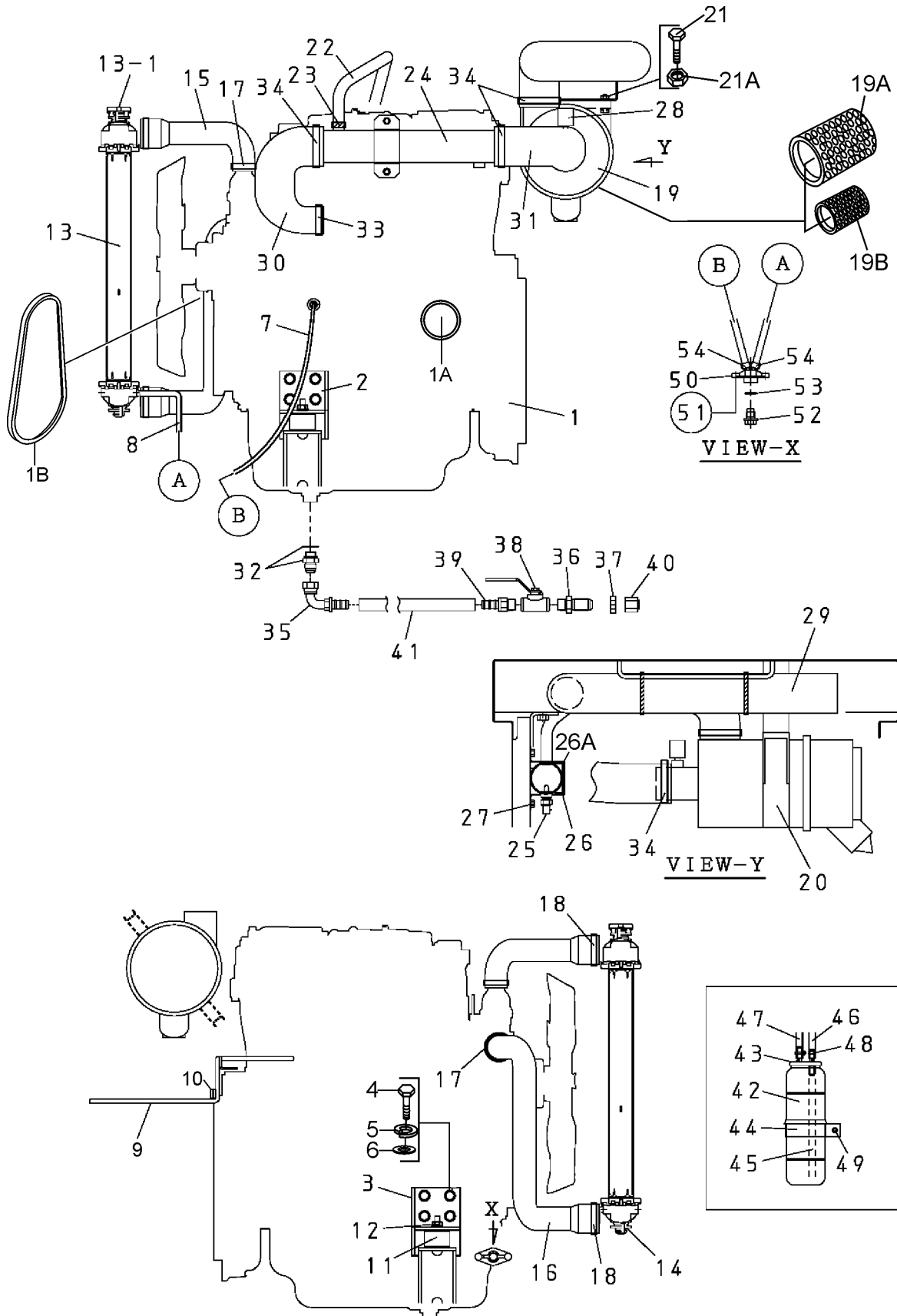

## ENGINE AND RADIATOR ASSY.

<u>NO.</u>	<u>PART NO.</u>	<u>PART NAME</u>	<u>QTY.</u>	<u>REMARKS</u>
1	M1924200074	ENGINE, ISUZU 4LE2T	1	
1A	2944566410	ELEMENT, OIL FILTER	1	
1B	8980490340	FAN BELT	1	
2	M1303200304	ENGINE FOOT	1	
3	M1305200204	ENGINE FOOT	1	
4	0105091025	HEX. HEAD BOLT.....	8.....	REPLACES P/N 0010310025
5	0040010000	WASHER, LOCK	8	
6	031110160	WASHER, FLAT.....	8.....	REPLACES P/N 0041210000
7	0199900900	DRAIN HOSE	1	
8	Y0199900680	DRAIN HOSE	1	
9	M1358300403	CLAMPER ROD	1	
10	012210020	HEX. HEAD BOLT.....	2.....	REPLACES P/N 0017110020
11	Y0605000408	RUBBER SUSPENSION	2	
12	021112140	HEX. NUT.....	2.....	REPLACES P/N 0207010000
13	M1924200054	RADIATOR	1	
13-1	Y0602015700	CAP	1	
14	M9312200104	MOUNT RUBBER	4	
15	M1311500203	RADIATOR HOSE	1	
16	M1311500303	RADIATOR HOSE	1	
17	0605515149	HOSE BAND	2	
18	0605515147	HOSE BAND	2	
19	Y0602046590	AIR CLEANER	1	
19A	PMAF25436	PRIMARY ELEMENT.....	1.....	REPLACES P/N 0602046309
19B	P822769	SAFETY ELEMENT.....	1.....	REPLACES P/N 0602046689
20	Y0602040553	AIR CLEANER BAND	1	
21	011208030	HEX. HEAD BOLT.....	2.....	REPLACES P/N 0016908030
21A	020108060	SELF-LOCKING-NUT.....	2.....	REPLACES P/N 0207008000
22	0269200520	PUSH-LOCK-HOSE	1	
23	0605515198	HOSE BAND	2	
24	M1374000003	AIR CLEANER PIPE	1	
25	8121468300	INLET AIR TEMPERATURE SENSOR.....	1.....	REPLACES P/N 0603210240
26	M1374200204	BRACKET, AIR CLEANER PIPE	1	
26A	Y0222100060	RUBBER SEAL	1	
27	011008020	HEX. HEAD BOLT.....	2.....	REPLACES P/N 0016908020
28	0602040651	INDICATOR, AIR CLEANER	1	
29	M1374100203	AIR CLEANER HOSE	1	
30	M1374100303	AIR CLEANER HOSE	1	
31	M1374100403	AIR CLEANER HOSE	1	
32	0602022581	ADAPTER 10M 24 X 2.0	1	
33	0605515147	HOSE BAND	1	
34	9500202080	HOSE BAND.....	4.....	REPLACES P/N 0605515178
35	0602022561	90 DEG. ELBOW	1	
36	0603306590	CONNECTOR	1	
37	0603300285	LOCKNUT	1	

# ENGINE AND RADIATOR ASSY. (CONTINUED)

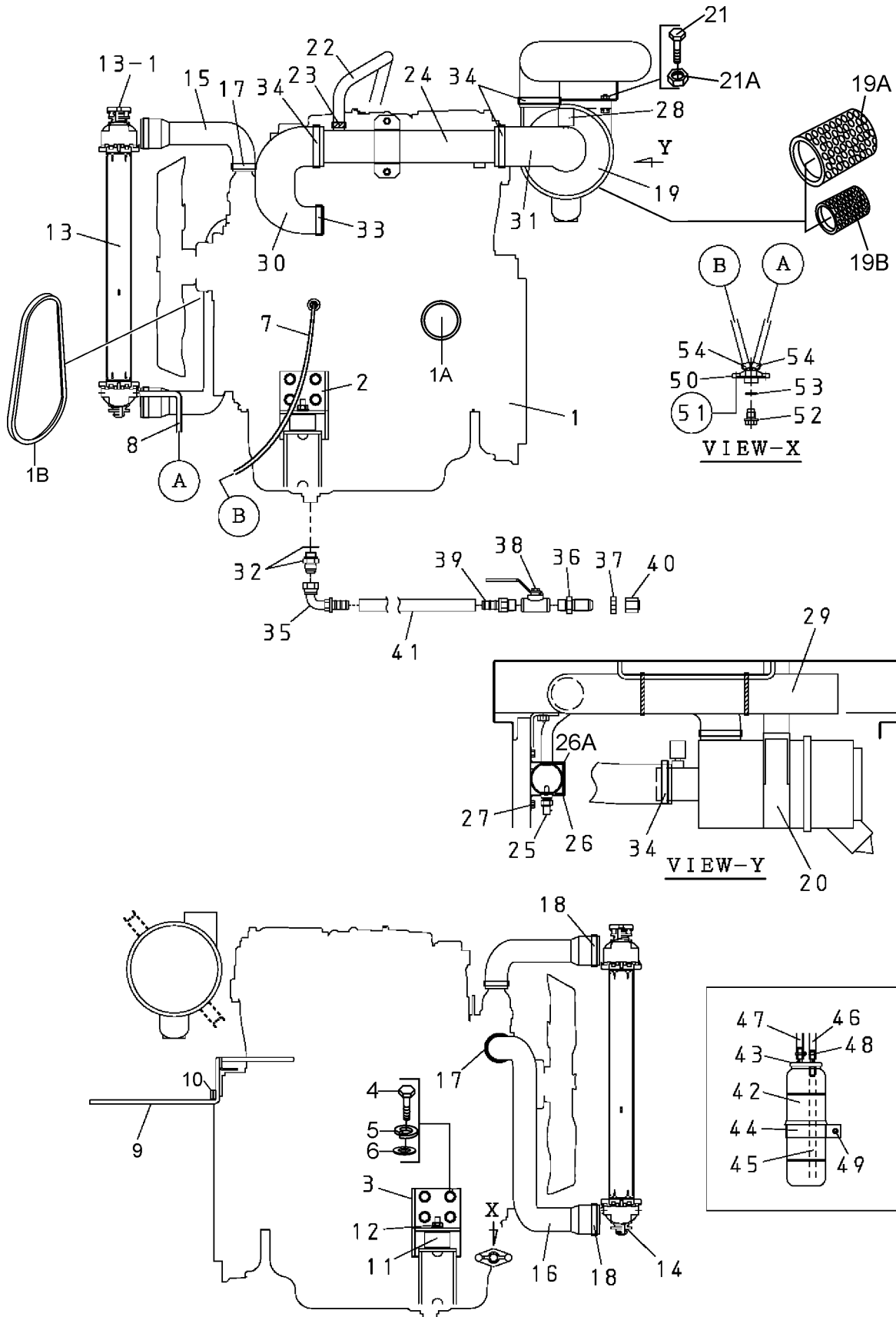

## ENGINE AND RADIATOR ASSY. (CONTINUED)

<u>NO.</u>	<u>PART NO.</u>	<u>PART NAME</u>	<u>QTY.</u>	<u>REMARKS</u>
38	0605511395	VALVE	1	
39	0603306395	HOSE JOINT	1	
40	0602021070	CAP	1	
41	0269200600	DRAIN HOSE	1	
42	0802081403D	RESERVE TANK.....	1	REPLACES P/N M9300000003
43	0802081104	CAP, RESERVE TANK.....	1	REPLACES P/N M9300100003
44	M1317100004	BRACKET, RESERVE TANK	1	
45	0199100215	HOSE	1	
46	Y0199900520	OVER FLOW HOSE	1	
47	0193601000	OVER FLOW HOSE	1	
48	0605515189	HOSE BAND	2	
49	011008020	HEX. HEAD BOLT.....	1	REPLACES P/N 0016908020
50	1622014103	DRAIN JOINT.....	1	REPLACES P/N M9602000003
51	011206020	HEX. HEAD BOLT.....	2	REPLACES P/N 0016906020
52	0802011104	DRAIN BOLT.....	1	REPLACES P/N M9200200004
53	0150000018	O-RING	1	
54	0605515189	HOSE BAND	4	

# OUTPUT TERMINAL ASSY.

ADD THE FOLLOWING DIGITS AFTER THE PART NUMBER WHEN ORDERING ANY PAINTED PANEL TO INDICATE COLOR OF UNIT:

1-ORANGE	6-CATERPILLAR YELLOW
2-WHITE	7-CATO GOLD
3-SPECTRUM GREY	8-RED
4-SUNBELT GREEN	9-DESERT TAN
5-BLACK	

THE SERIAL NUMBER MAY BE REQUIRED.

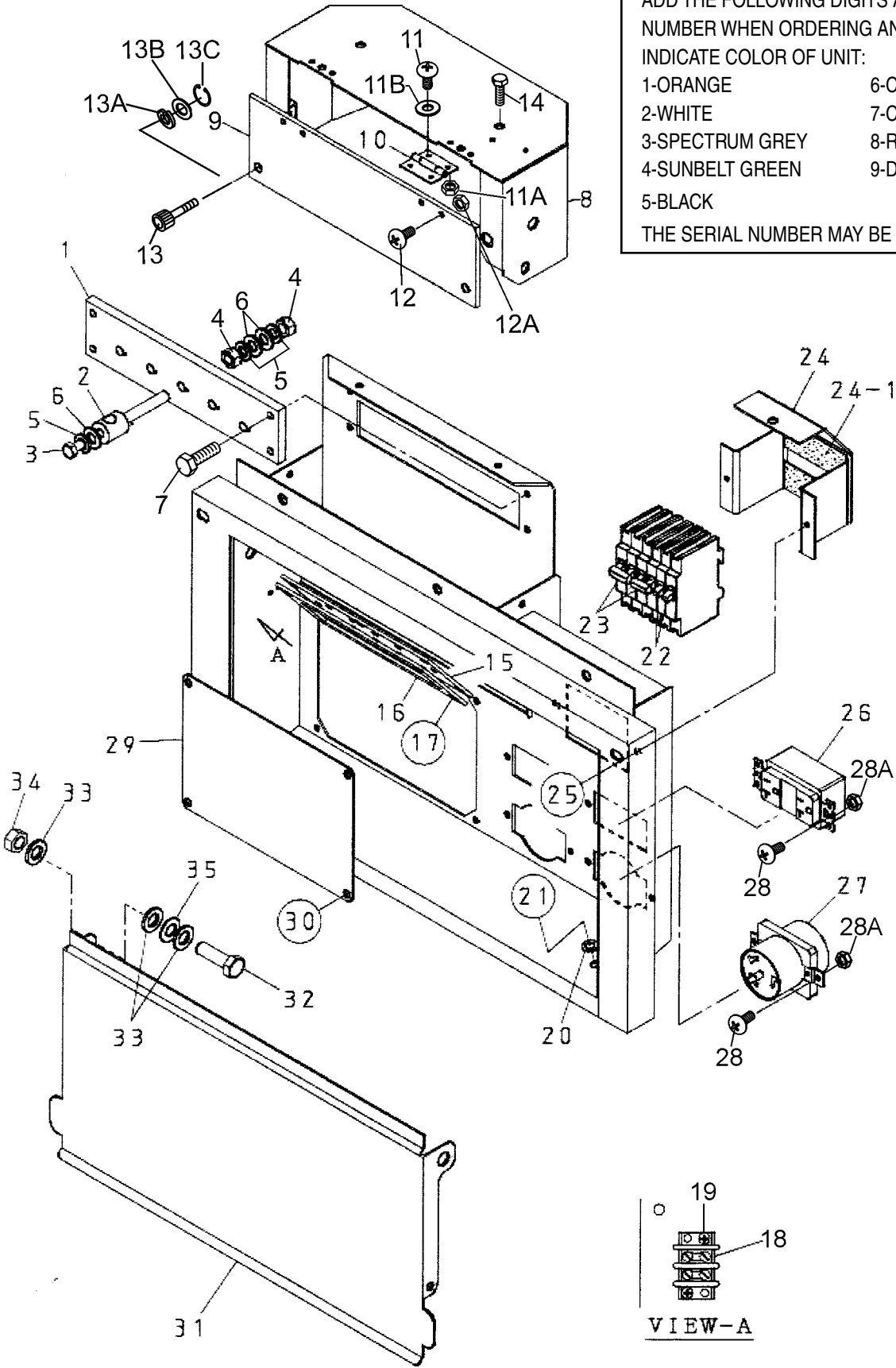

## OUTPUT TERMINAL ASSY.

<u>NO.</u>	<u>PART NO.</u>	<u>PART NAME</u>	<u>QTY.</u>	<u>REMARKS</u>
1	8091860103	TERMINAL PANEL .....	1.....	REPLACES P/N M1230700003
2	0801830104A	OUTPUT TERMINAL BOLT .....	5.....	REPLACES P/N M9220000004
3	0801832204	TIE BOLT .....	5.....	REPLACES P/N M9220000104
4	0039308000	HEX. NUT	10	
5	0040008000	WASHER, LOCK	15	
6	0041408000	WASHER, FLAT	20	
7	011206020	HEX. HEAD BOLT.....	4.....	REPLACES P/N 0016906020
8	M1237100103	3-PHASE OUTPUT TERMINAL COVER	1	
9	M1236100404	OUTPUT WINDOW	1	
10	0605010040	HINGE	2	
11	0027103010	MACHINE SCREW	4	
11A	0207003000	HEX. NUT .....	4.....	REPLACES P/N 0030003000
11B	0041203000	WASHER, FLAT	4	
12	0027103010	MACHINE SCREW	4	
12A	0207003000	HEX. NUT .....	4.....	REPLACES P/N 0030003000
13	M9220100804	SET SCREW	2	
13A	0040006000	WASHER, LOCK	2	
13B	952404470	WASHER, FLAT .....	2.....	REPLACES P/N 0041206000
13C	0080200005	E-SNAP RING	2	
14	011106015	HEX. HEAD BOLT.....	4.....	REPLACES P/N 0016906015
15	M1236400004	CABLE OUTLET COVER	1	
16	M1236300004	SUPPORTER, CABLE OUTLET COVER	1	
17	011206020	HEX. HEAD BOLT.....	6.....	REPLACES P/N 0016906020
18	0601815194	TERMINAL BLOCK	1	
19	7538070	MACHINE SCREW.....	2.....	REPLACES P/N 0027104015
20	0040508000	TOOTHED WASHER	1	
21	0019208020	HEX. HEAD BOLT	1	
22	0601870440	CIRCUIT BREAKER 1P 20A	2	
23	0601870441	CIRCUIT BREAKER 2P 50A	2	
24	M1260700404	BREAKER FITTING COVER	1	
24-1	0222100080	CUSHION RUBBER	2	
25	011206020	HEX. HEAD BOLT.....	2.....	REPLACES P/N 0016906020
26	0601814013	RECEPTACLE 125V @ 20A	2	
27	0601814014	RECEPTACLE 250V @ 50A	2	
28	7538070	MACHINE SCREW.....	8.....	REPLACES P/N 0027104015
28A	OEMAA8	HEX. NUT .....	8.....	REPLACES P/N 0207004000
29	M1236400104	COVER	1	
30	011106015	HEX. HEAD BOLT .....	4.....	REPLACES P/N 0016906015
31	M1237100003	TERMINAL COVER	1	
32	012212045	HEX. HEAD BOLT.....	2.....	REPLACES P/N 0010112045
33	031112230	WASHER, FLAT.....	6.....	REPLACES P/N 0041212000
34	0030012000	HEX. NUT DOUBLE NUT	2	
35	0605050060	CONICAL LOCK WASHER	2	

# BATTERY ASSY.

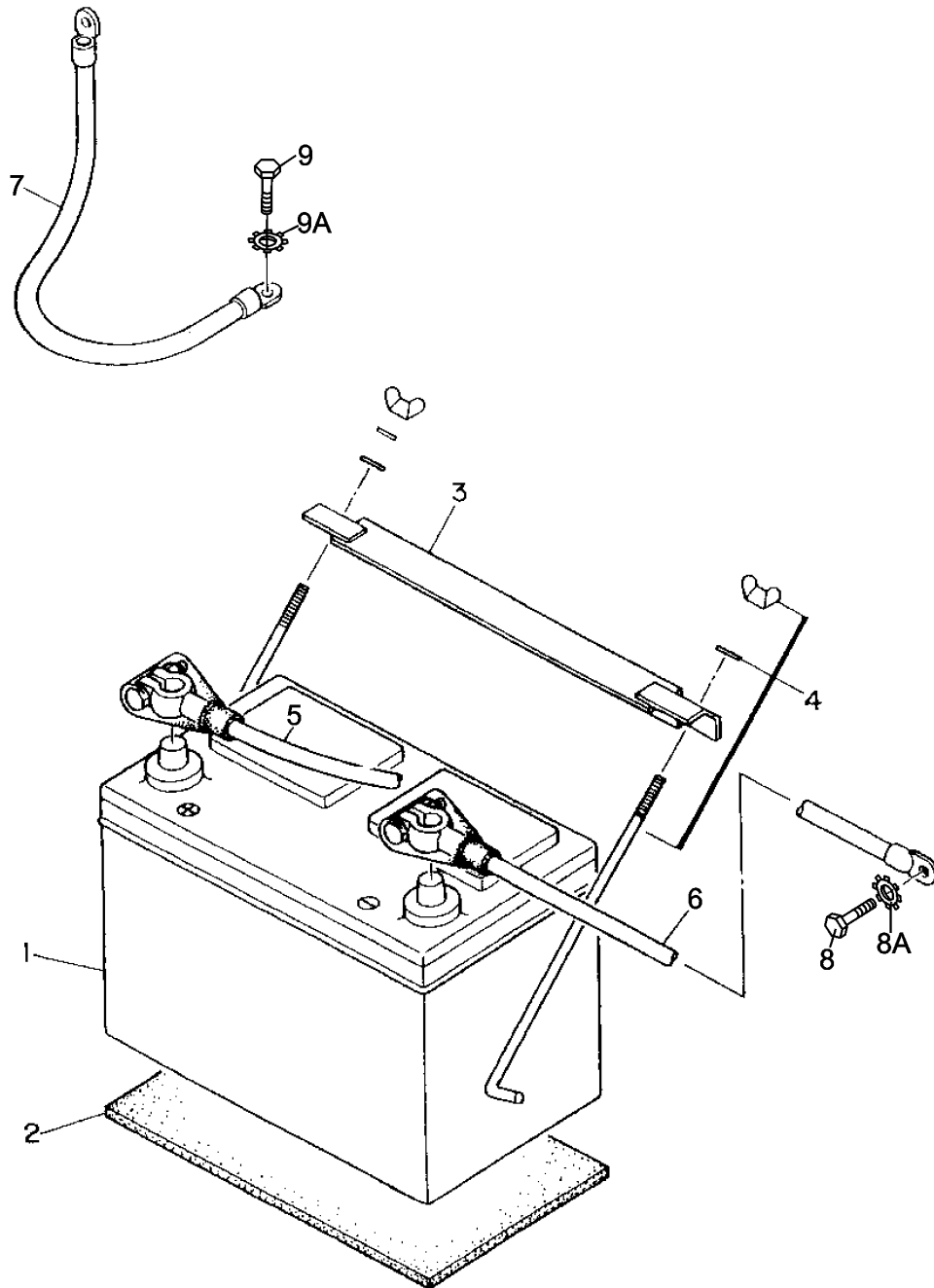



## BATTERY ASSY.

---

<u>NO.</u>	<u>PART NO.</u>	<u>PART NAME</u>	<u>QTY.</u>	<u>REMARKS</u>
1	0602220185	BATTERY	1	
2	M9310500014	BATTERY SHEET	1	
3	M9103000304	BATTERY BAND	1	
4	0602220920	BATTERY BOLT SET 1/4-L10"	2	
5	M1346400004	BATTERY CABLE	1	
6	M2346900304	BATTERY CABLE	1	
7		CABLE .....	1	MAKE LOCALLY
8	0017110025	HEX. HEAD BOLT	1	
8A	0040510000	TOOTHED WASHER	1	
9	0019208020	HEX. HEAD BOLT	1	
9A	0040508000	TOOTHED WASHER	1	

# MUFFLER ASSY.

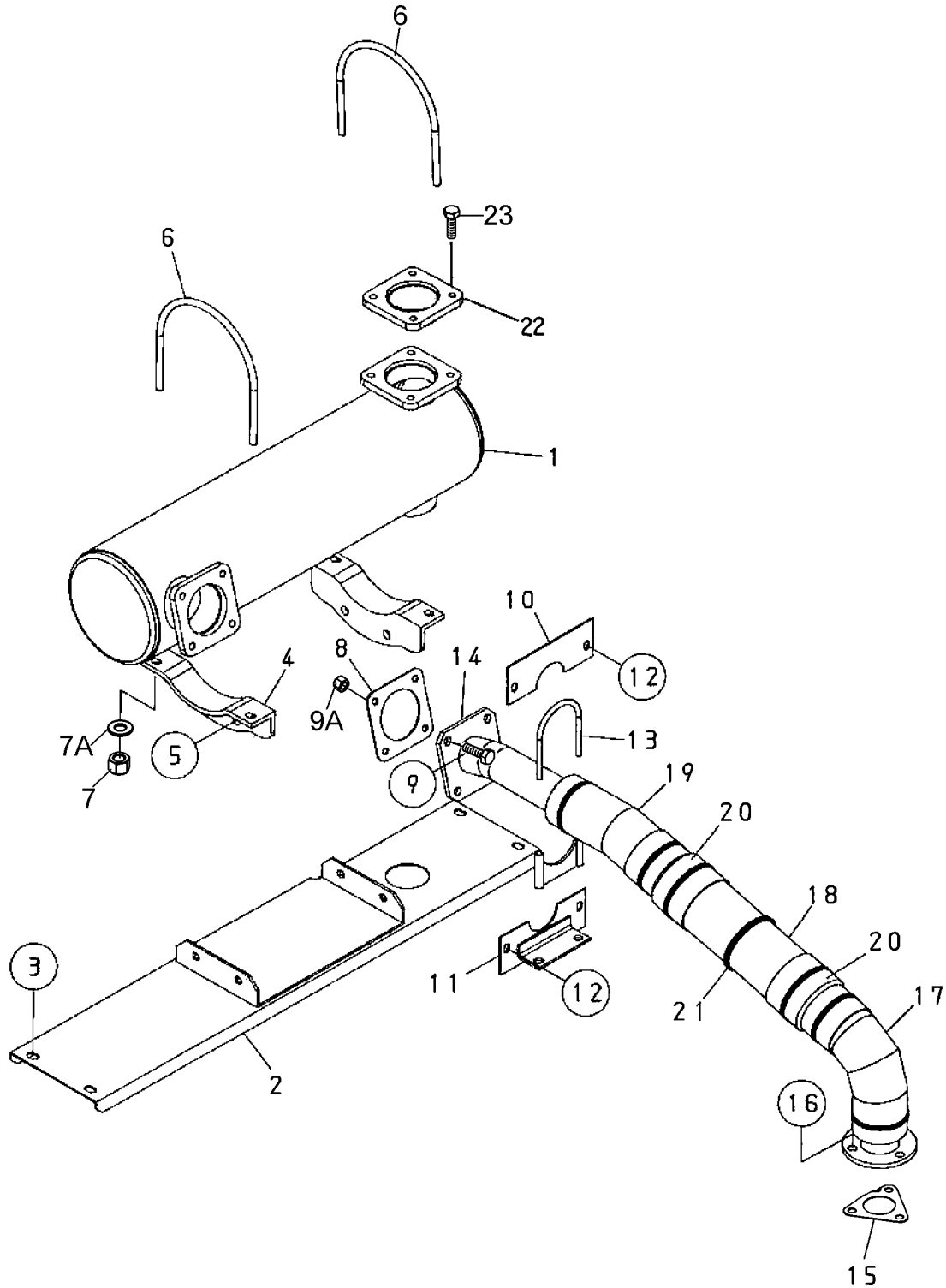

## MUFFLER ASSY.

<u>NO.</u>	<u>PART NO.</u>	<u>PART NAME</u>	<u>QTY.</u>	<u>REMARKS</u>
1	8982353890	DOC .....	1.....	REPLACES P/N Y0602330111
2	M1331400103	DOC BRACKET	1	
3	011008020	HEX. HEAD BOLT .....	4.....	REPLACES P/N 0016908020
4	8982284330	DOC SUPPORT .....	2 .....	REPLACES P/N Y0602330210
5	0016910025	HEX. HEAD BOLT	4	
6	8982103230	U-BOLT .....	2.....	REPLACES P/N Y0602322091
7	020108060	SELF-LOCKING NUT .....	4.....	REPLACES P/N 0037908000
7A	0401450080	WASHER, FLAT .....	4.....	REPLACES P/N 0041208000
8	8973731080	GASKET .....	1.....	REPLACES P/N Y0602320212
9	8980435280	HEX. HEAD BOLT .....	4.....	REPLACES P/N Y0602322090
9A	8971616070	HEX. NUT .....	4.....	REPLACES P/N Y0602323007
10	M1331400204	COVER, EXHAUST PIPE	1	
11	M1331400304	BRACKET, EXHAUST PIPE	1	
12	011106015	HEX. HEAD BOLT .....	4.....	REPLACES P/N 0016906015
13	Y0602326066	U-BOLT	1	
14	M1334000703	EXHAUST PIPE	1	
15	8973679180	GASKET .....	1.....	REPLACES P/N Y0602320211
16	0207108000	SELF-LOCKING NUT	3	
17	M1331400504	EXHAUST HEAT SHIELD (A)	1	
18	M1331400904	EXHAUST HEAT SHIELD (B)	1	
19	M1331401004	EXHAUST HEAT SHIELD (C)	1	
20	Y0272100270	HEAT SHIELD TAPE	2	
21	Y0602325051	METAL CABLE TIE	7	
22	M1334300504	FLANGE.....	1.....	S/N 7150399 AND ABOVE
23	011008020	HEX HEAD BOLT .....	4.....	S/N 7150399 AND ABOVE REPLACES P/N 0016908020

# FUEL TANK ASSY.

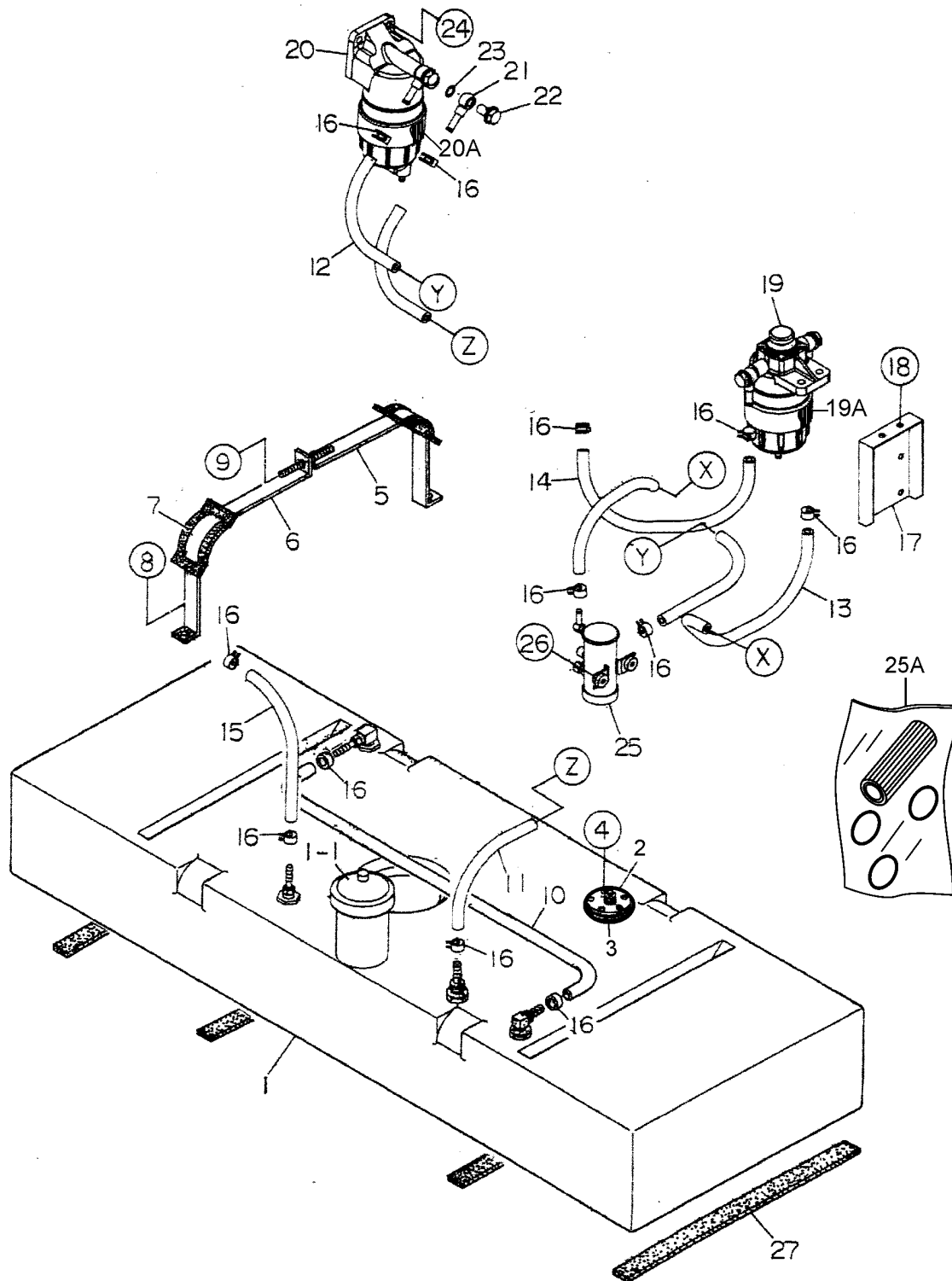

## FUEL TANK ASSY.

<u>NO.</u>	<u>PART NO.</u>	<u>PART NAME</u>	<u>QTY.</u>	<u>REMARKS</u>
1	M1364000302	FUEL TANK	1	
1-1	0605505070	CAP, FUEL TANK	1	
2	0605501071	FUEL SENDER UNIT	1	
3	0605516090	GASKET	1	
4	7538070	MACHINE SCREW .....	5.....	REPLACES P/N 0027104015
5	M1363200304	TANK BAND	2	
6	M1365200204	TANK BAND	2	
7	M9310500104	SUPPORTER SHEET	4	
8	011008020	HEX. HEAD BOLT .....	4.....	REPLACES P/N 0016908020
9	020108060	SELF-LOCKING NUT .....	4.....	REPLACES P/N 0207008000
10	0191301200	VENT HOSE	1	
11	Y0191300820	SUCTION HOSE	1	
12	Y0191300790	SUCTION HOSE	1	
13	0191301150	SUCTION HOSE	1	
14	0191300900	SUCTION HOSE	1	
15	0191301300	RETURN HOSE	1	
16	0605515189	HOSE BAND	12	
17	M1367700104	FUEL FILTER BRACKET	1	
18	011008020	HEX. HEAD BOLT .....	4.....	REPLACES P/N 0016908020
19	8982369900	FUEL FILTER (MAIN) .....	1.....	REPLACES P/N 0602042428
19A	8982402790	ELEMENT, FUEL FILTER (MAIN)	1	
20	8982369910	FUEL FILTER (PRE.).....	1.....	REPLACES P/N 0602042429
20A	8982402800	ELEMENT, FUEL FILTER (PRE)	1	
21	8981263320	JOINT PIPE .....	4.....	REPLACES P/N Y0602042623
22	1096751930	EYE BOLT .....	4.....	REPLACES P/N Y0602042624
23	1096300850	PACKING .....	8.....	REPLACES P/N Y0602021700
24	012210035	HEX. HEAD BOLT .....	4.....	REPLACES P/N 0017110035
25	8980682750	FUEL FEED PUMP.....	1.....	REPLACES P/N 0602023240
25A	8981731650	KIT, FUEL PUMP	1	
26	011606025	HEX. HEAD BOLT .....	2.....	REPLACES P/N 0016906025
27	0222100550	RUBBER SEAL	4	

# ENCLOSURE ASSY.

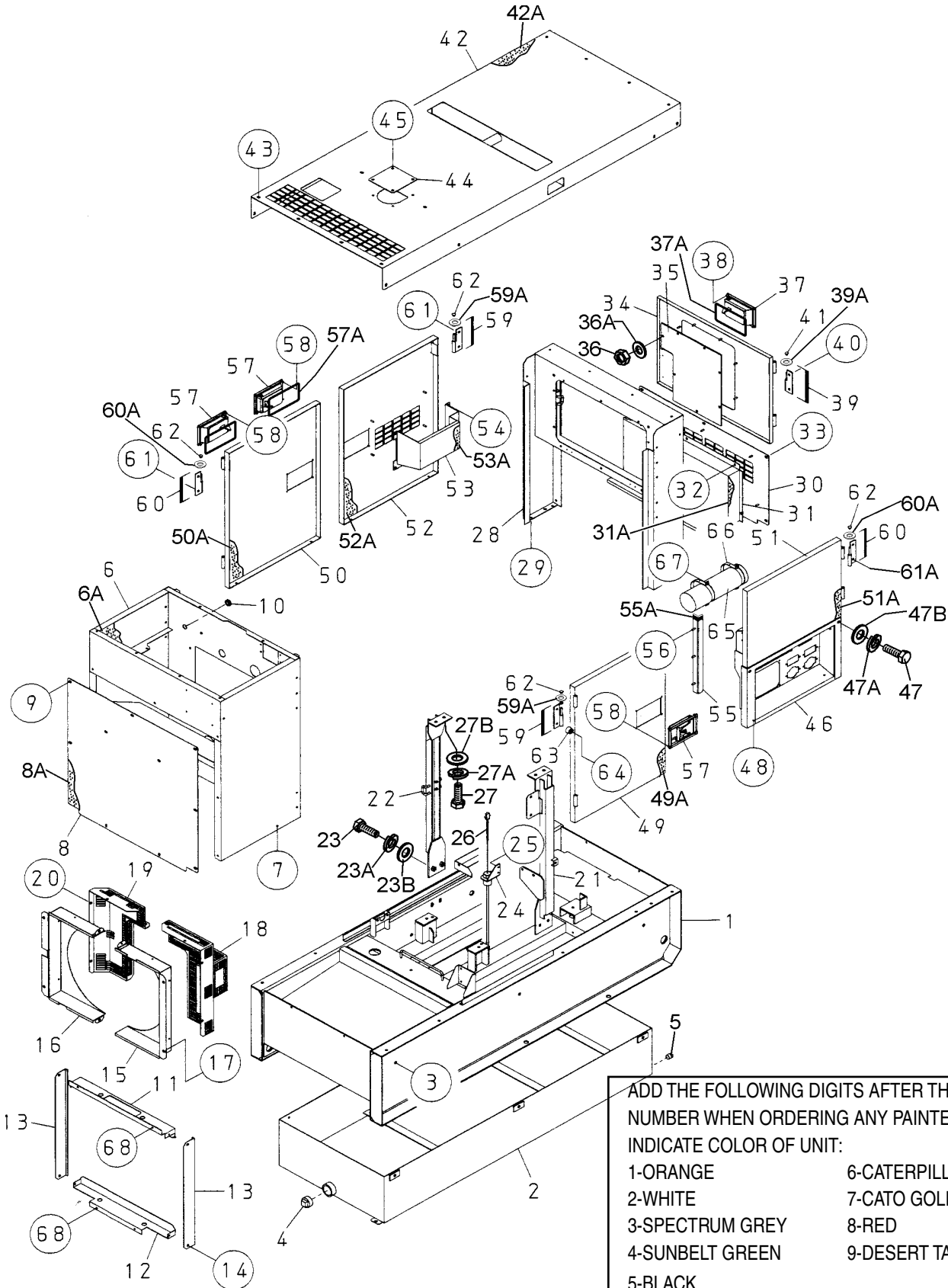

ADD THE FOLLOWING DIGITS AFTER THE PART NUMBER WHEN ORDERING ANY PAINTED PANEL TO INDICATE COLOR OF UNIT:

1-ORANGE	6-CATERPILLAR YELLOW
2-WHITE	7-CATO GOLD
3-SPECTRUM GREY	8-RED
4-SUNBELT GREEN	9-DESERT TAN
5-BLACK	

THE SERIAL NUMBER MAY BE REQUIRED.

## ENCLOSURE ASSY.

<u>NO.</u>	<u>PART NO.</u>	<u>PART NAME</u>	<u>QTY.</u>	<u>REMARKS</u>
1	M1414000502	BASE	1	
2	M1415100202	ENVIRONMENTAL TANK	1	
3	0016910025	HEX. HEAD BOLT	6	
4	0603306797	SQUARE HEAD PIPE PLUG 1-1/2"	1	
5	Y0603306793	SQUARE HEAD PIPE PLUG 1/2"	1	
6	M1424000602	FRONT FRAME	1	
6A	M1494101703	ACOUSTIC SHEET	1	
7	011008020	HEX. HEAD BOLT .....	4	REPLACES P/N 0016908020
8	M1424200903	COVER, FRONT FRAME	1	
8A	M1494101804	ACOUSTIC SHEET	1	
9	0019208020	HEX. HEAD BOLT	11	
10	0601850239	GROMMET	1	
11	M1311200004	RADIATOR BRACKET	1	
12	M1311200104	RADIATOR BRACKET	1	
13	M1311200204	RADIATOR BRACKET	2	
14	011008020	HEX. HEAD BOLT .....	4	REPLACES P/N 0016908020
15	M1311600203	FAN SHROUD	1	
16	M1311600303	FAN SHROUD	1	
17	011008020	HEX. HEAD BOLT .....	6	REPLACES P/N 0016908020
18	M1311300103	FAN GUARD	1	
19	M1311300203	FAN GUARD	1	
20	011008020	HEX. HEAD BOLT .....	6	REPLACES P/N 0016908020
21	M1434000003	CENTER FRAME	1	
22	M1434000103	CENTER FRAME	1	
23	0012312030	HEX. HEAD BOLT .....	4	REPLACES P/N 0013612030
23A	0040012000	WASHER, LOCK	4	
23B	031112230	WASHER, FLAT .....	4	REPLACES P/N 0041212000
24	M1484500104	FUEL LEAK SWITCH BRACKET	1	
25	011206020	HEX. HEAD BOLT .....	2	REPLACES P/N 0016906020
26	0605503066	FUEL LEAK DETECTED SWITCH	1	
27	0012312030	HEX. HEAD BOLT .....	4	REPLACES P/N 0013612030
27A	0040012000	WASHER, LOCK	4	
27B	031112230	WASHER, FLAT .....	4	REPLACES P/N 0041212000
28	M1444000202	REAR FRAME	1	
29	011008020	HEX. HEAD BOLT .....	4	REPLACES P/N 0016908020
30	M1444300103	REAR COVER	1	
31	M1444800303	DUCT, REAR COVER	1	
31A	M1494301103	ACOUSTIC SHEET	1	
32	0176060030	SELF-LOCKING NUT .....	5	REPLACES P/N 0207006000
33	0019208020	HEX. HEAD BOLT	7	
34	M1444200103	REAR DOOR	1	
35	M1444600104	WINDOW PLATE	1	
36	020106050	LOCK NUT .....	7	REPLACES P/N 0037906000
36A	952404470	WASHER, FLAT .....	7	REPLACES P/N 0041206000
37	Y0605012309	DOOR HANDLE ASSY.	1	
37A	C9312500004	SEAL RUBBER	1	

# ENCLOSURE ASSY. (CONT.)

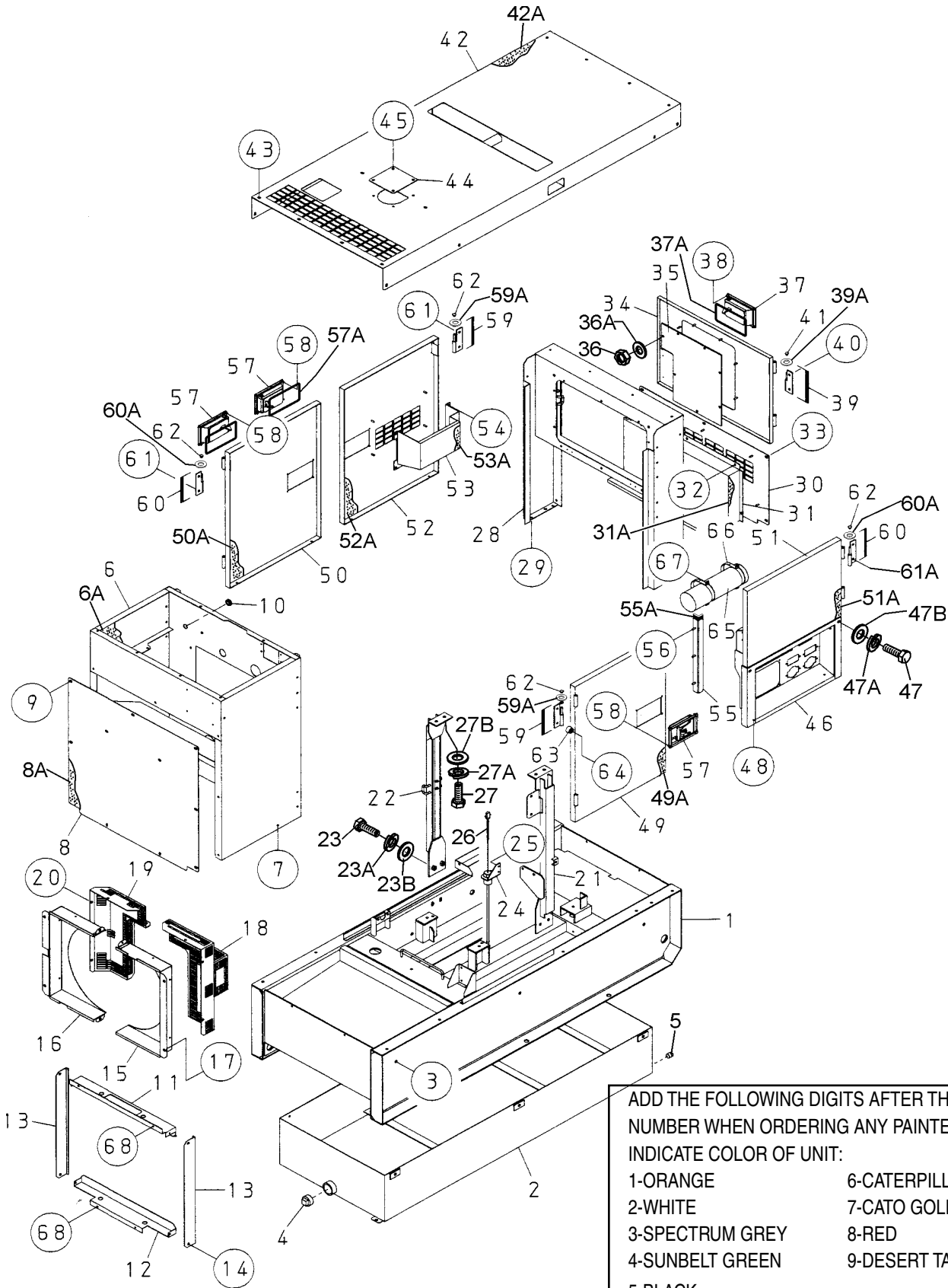

ADD THE FOLLOWING DIGITS AFTER THE PART NUMBER WHEN ORDERING ANY PAINTED PANEL TO INDICATE COLOR OF UNIT:

1-ORANGE	6-CATERPILLAR YELLOW
2-WHITE	7-CATO GOLD
3-SPECTRUM GREY	8-RED
4-SUNBELT GREEN	9-DESERT TAN
5-BLACK	

THE SERIAL NUMBER MAY BE REQUIRED.



## ENCLOSURE ASSY. (CONT.)

<b>NO.</b>	<b>PART NO.</b>	<b>PART NAME</b>	<b>QTY.</b>	<b>REMARKS</b>
38	0176060030	SELF-LOCKING NUT .....	4.....	REPLACES P/N 0207006000
39	M9110100204	HINGE	2	
39A	M9116100004	WASHER	2	
40	0019208020	HEX. HEAD BOLT	3	
41	0845031504	BLIND PLUG.....	2.....	REPLACES P/N M9310000004
42	M1464000102	ROOF PANEL	1	
42A	M1494500703	ACOUSTIC SHEET	1	
43	0019208020	HEX. HEAD BOLT	18	
44	M3310600004	COVER	1	
45	0019208020	HEX. HEAD BOLT	4	
46	M1454200302	SPLASHER PANEL	1	
47	0019108055	HEX. HEAD BOLT	1	
47A	0042308000	WASHER, LOCK	2	
47B	031108160	WASHER, FLAT .....	2.....	REPLACES P/N 0042408000
48	011008020	HEX. HEAD BOLT .....	2.....	REPLACES P/N 0016908020
49	M1454000603	SIDE DOOR	1	
49A	M1494400604	ACOUSTIC SHEET	1	
50	M1454000703	SIDE DOOR	1	
50A	M1494400704	ACOUSTIC SHEET	1	
51	M1454000803	SIDE DOOR	1	
51A	M1494400804	ACOUSTIC SHEET	1	
52	M1454000903	SIDE DOOR	1	
52A	M1494400904	ACOUSTIC SHEET	1	
53	M1454300204	DUCT	1	
53A	M1494401204	ACOUSTIC SHEET	1	
54	0176060030	SELF-LOCKING NUT .....	5.....	REPLACES P/N 0207006000
55	M1454700004	DOOR SUPPORTER	1	
55A	Y0229200400	RUBBER SEAL	1	
56	0176060030	SELF-LOCKING NUT .....	3.....	REPLACES P/N 0207006000
57	Y0605012309	DOOR HANDLE ASSY.	3	
57A	C9312500004	SEAL RUBBER	3	
58	0176060030	SELF-LOCKING NUT .....	12.....	REPLACES P/N 0207006000
59	M9110100204	HINGE	4	
59A	M9116100004	WASHER	4	
60	M9110100304	HINGE	4	
60A	M9116100004	WASHER	4	
61	0019208020	HEX. HEAD BOLT	9	
62	0845031504	BLIND PLUG.....	8.....	REPLACES P/N M9310000004
63	0601850097	DOOR STOPPER	8	
64	0027208025	MACHINE SCREW	8	
65	0600800321	MANUAL PAK	1	
66	M1483600804	CLAMPER, MANUAL-PAK	2	
67	011106015	HEX. HEAD BOLT .....	4.....	REPLACES P/N 0016906015
68	011008020	HEX. HEAD BOLT .....	4.....	REPLACES P/N 0016908020

# RUBBER SEALS ASSY.

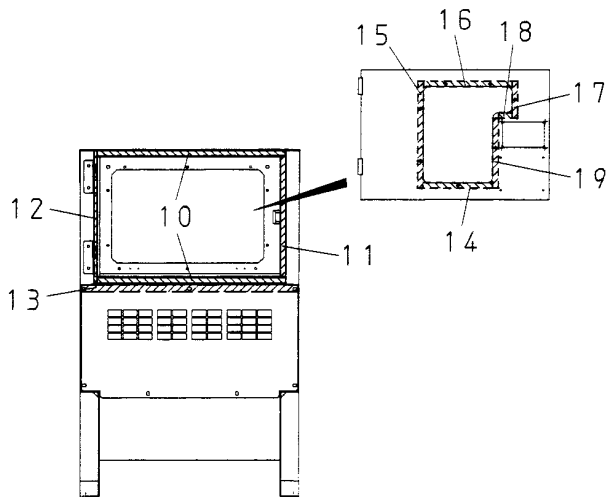
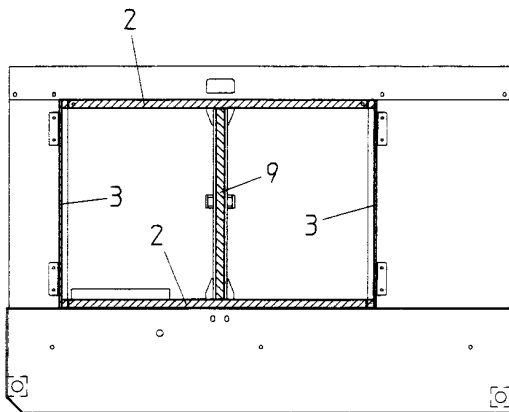
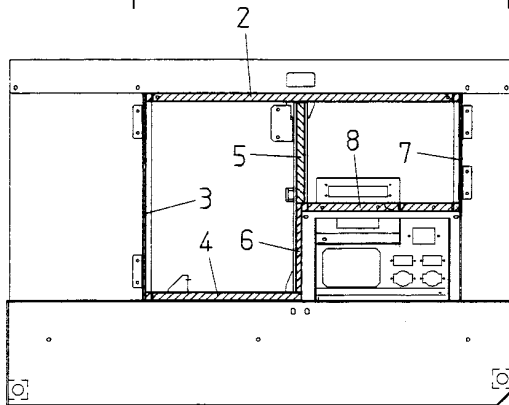
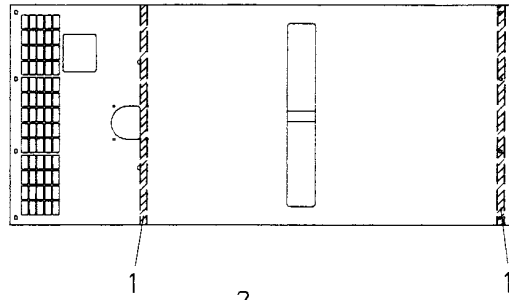

## **RUBBER SEALS ASSY.**

---

<u>NO.</u>	<u>PART NO.</u>	<u>PART NAME</u>	<u>QTY.</u>	<u>REMARKS</u>
1	Y0229200790	RUBBER SEAL	2	
2	Y0228901125	RUBBER SEAL	3	
3	0229400755	RUBBER SEAL	3	
4	0228900560	RUBBER SEAL	1	
5	0228900370	RUBBER SEAL	1	
6	0228800325	RUBBER SEAL	1	
7	0229400430	RUBBER SEAL	1	
8	0228900565	RUBBER SEAL	1	
9	0228900695	RUBBER SEAL	1	
10	Y0228800680	RUBBER SEAL	2	
11	Y0228800440	RUBBER SEAL	1	
12	Y0228800480	RUBBER SEAL	1	
13	Y0229200780	RUBBER SEAL	1	
14	Y0228100250	RUBBER SEAL	1	
15	0228100390	RUBBER SEAL	1	
16	0228100320	RUBBER SEAL	1	
17	Y0228100135	RUBBER SEAL	1	
18	Y0228100050	RUBBER SEAL	1	
19	Y0228100255	RUBBER SEAL	1	

# BATTERY CHARGER ASSY. (OPTION)

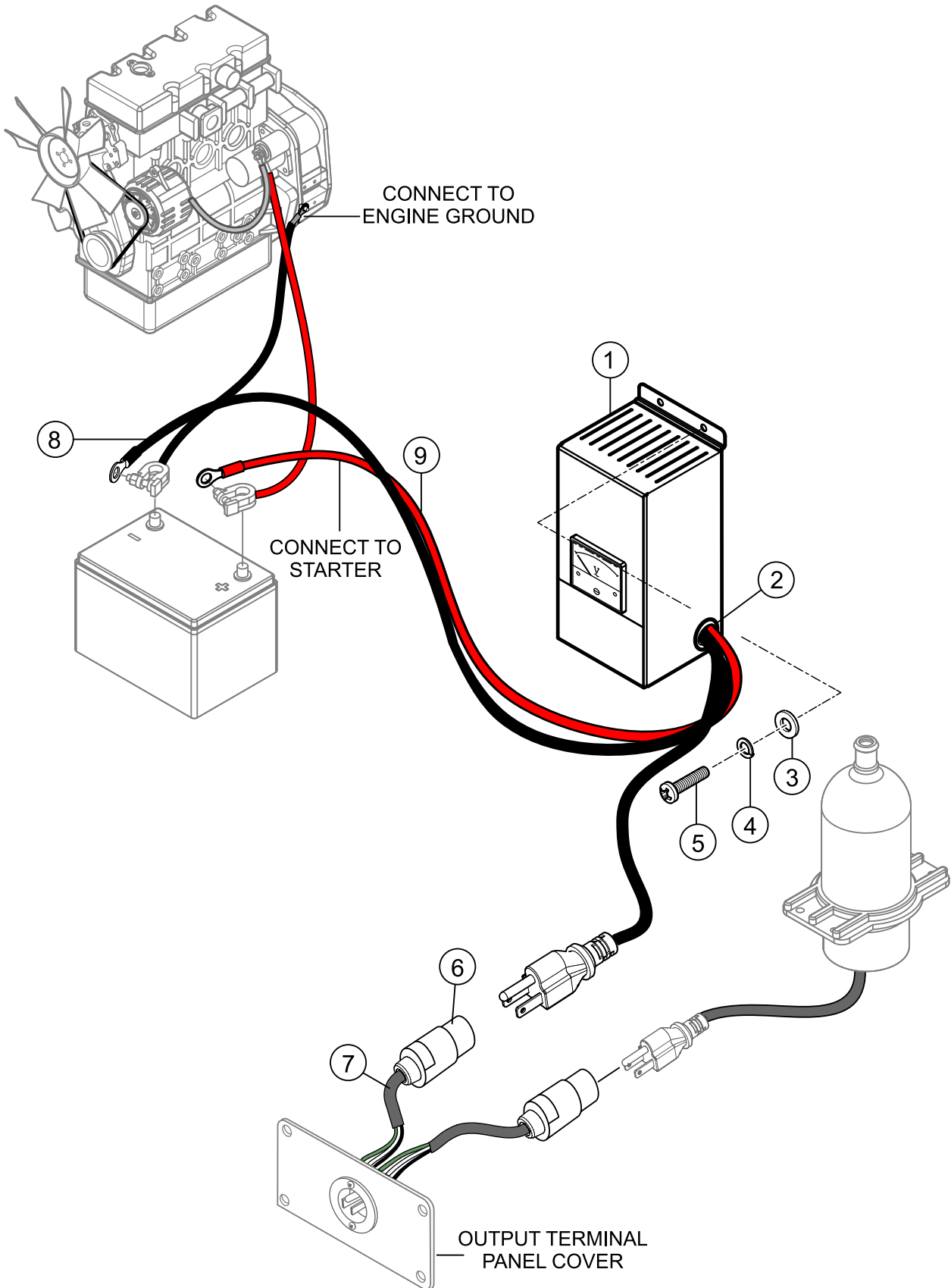

## **BATTERY CHARGER ASSY. (OPTION)**

---

<u>NO.</u>	<u>PART NO.</u>	<u>PART NAME</u>	<u>QTY.</u>	<u>REMARKS</u>
1	LC125002	CHARGER BATTERY, 3 AMP 12V .....	1	
2		GROMMET, 7/8" HOLE SIZE .....	1	OBTAIN LOCALLY
3	EE56557	CORD, 3-CONDUCTOR, 14 AWG .....	6 FT.	1PC=1FT
4		SCREW, M4X10 .....	4	OBTAIN LOCALLY
5		WASHER, LOCK M4.....	4	OBTAIN LOCALLY
6		WASHER, FLAT M4.....	4	OBTAIN LOCALLY
7		WIRE, 16GA, RED .....	9 FT.	OBTAIN LOCALLY
8		WIRE, 16GA, GREEN.....	9 FT.	OBTAIN LOCALLY

# JACKET WATER HEATER ASSY. (OPTION)

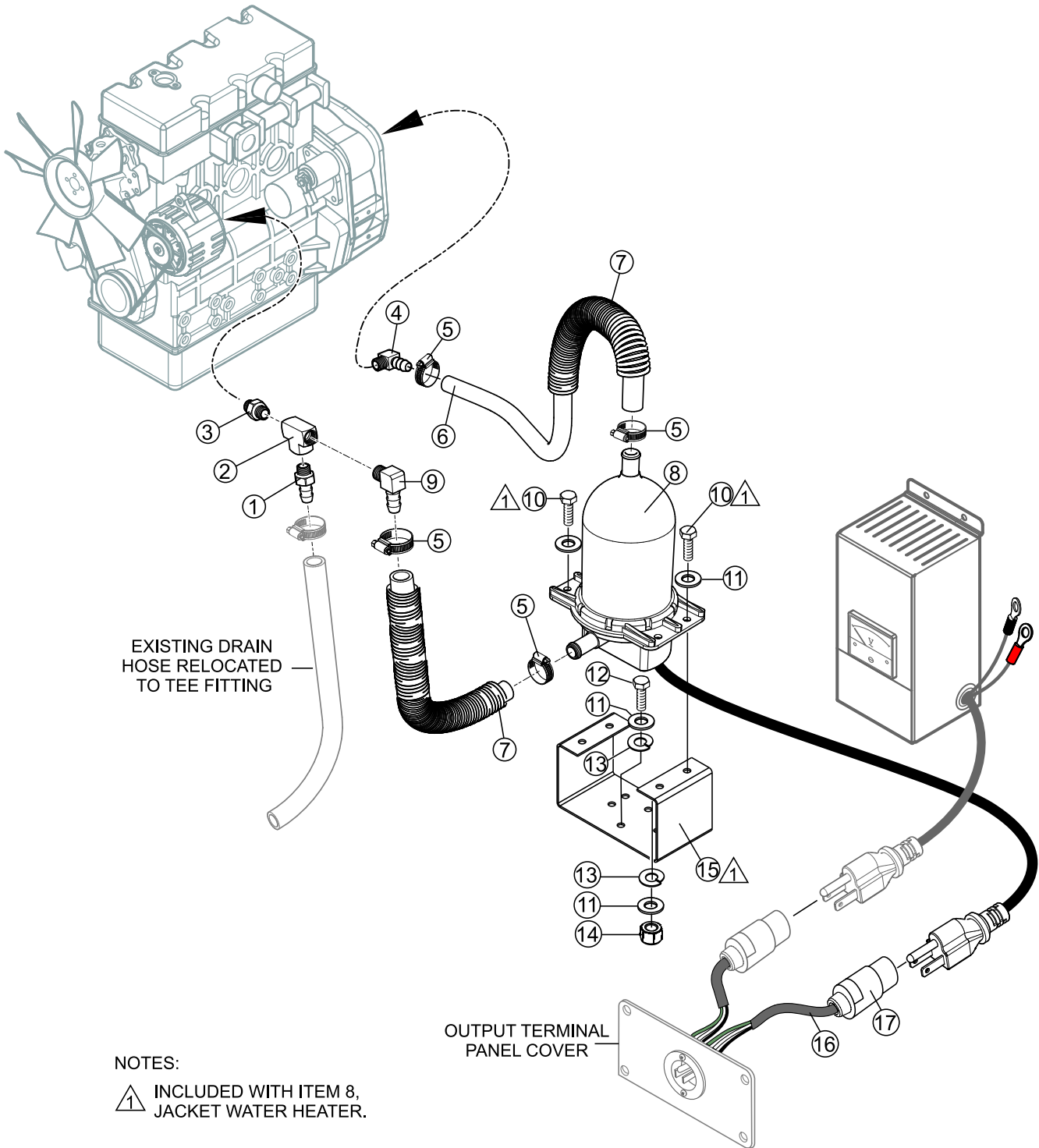

## **JACKET WATER HEATER ASSY. (OPTION)**

<b>NO.</b>	<b>PART NO.</b>	<b>PART NAME</b>	<b>QTY.</b>	<b>REMARKS</b>
1		1/4" MP X 5/16 HB NIPPLE .....	1.....	OBTAIN LOCALLY
2		1/4 X 1/4 1/4" FEMALE PIPE TEE.....	1.....	OBTAIN LOCALLY
3		1/4 X 1/4 MALE TO MALE PIPE NIPPLE .....	1.....	OBTAIN LOCALLY
4		3/8" MP X 5/8 HB 90° ELBOW.....	1.....	OBTAIN LOCALLY
5		HOSE CLAMP #10 .....	4.....	OBTAIN LOCALLY
6		HEATER HOSE, 5/8" ID X 30" LONG.....	1.....	OBTAIN LOCALLY
7		SPLIT LOOM, 1 " X 20" .....	2.....	OBTAIN LOCALLY
8	TPS051GT10000	HEATER, 500W, 120 VAC.....	1.....	INCLUDES ITEMS W/#
9		1/4" MP X 5/8" HB 90° ELBOW .....	1.....	OBTAIN LOCALLY
10#		BOLT, 1/4"-20 X 1" .....	4.....	OBTAIN LOCALLY
11		WASHER, FLAT 1".....	4.....	OBTAIN LOCALLY
12		BOLT, 1/4"-20 X 3/4" .....	6.....	OBTAIN LOCALLY
13		WASHER, LOCK 1/4" .....	6.....	OBTAIN LOCALLY
14		NUT, 1/4" .....	4.....	OBTAIN LOCALLY
15#	EE52911	BRACKET, HOT START	1	
16	EE56557	CORD, 3-CONDUCTOR, 14 AWG, 2 FT.	1	
17	HBL5369C	CONNECTOR, 20 AMP ,125V	1	

# NAMEPLATE AND DECALS ASSY.

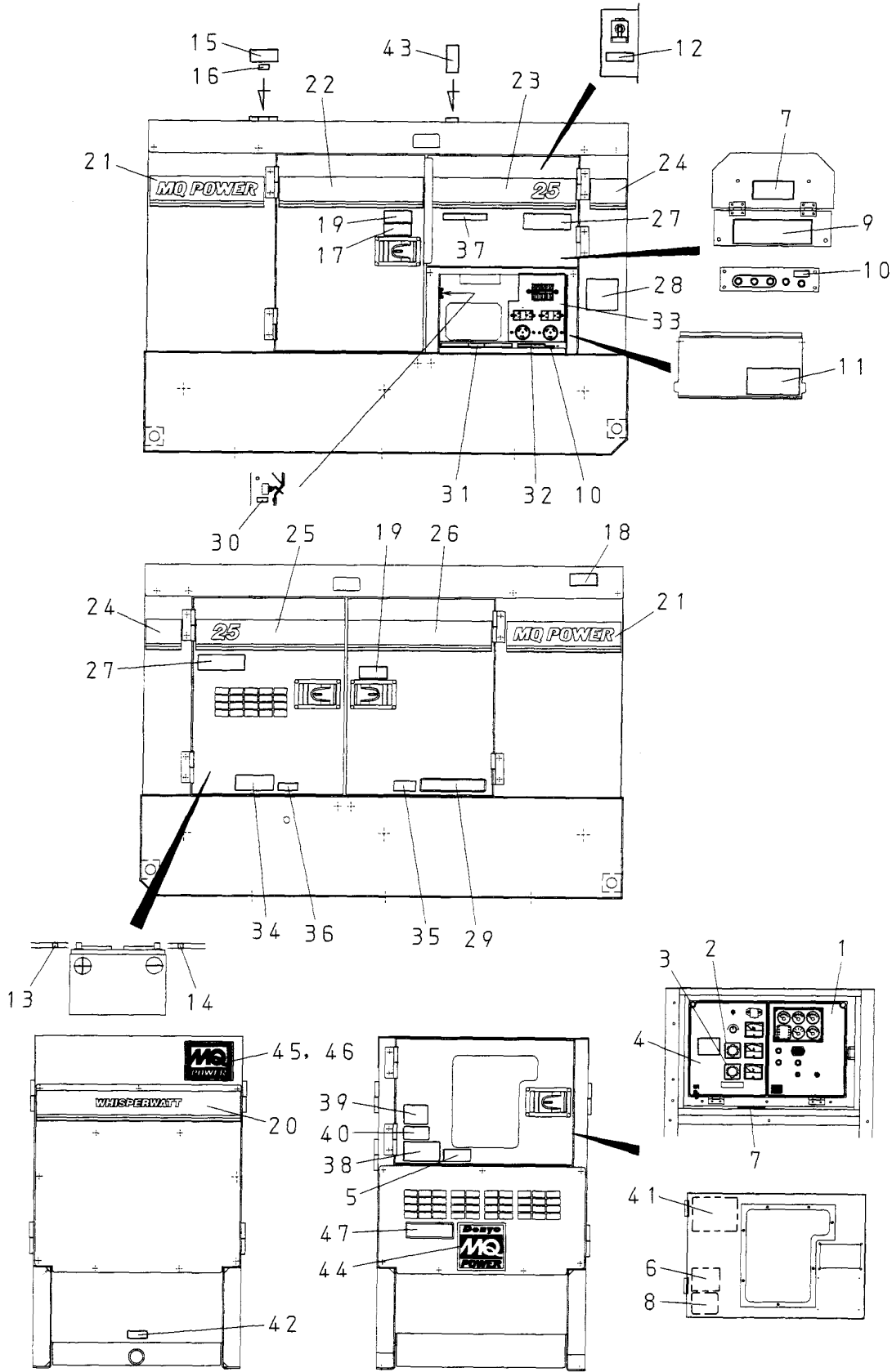



## NAMEPLATE AND DECALS ASSY.

<b>NO.</b>	<b>PART NO.</b>	<b>PART NAME</b>	<b>QTY.</b>	<b>REMARKS</b>
1	M1551000103	DECAL: ENGINE OPERATING.....	1.....	M15100010
2	M9520000104	DECAL: AMMETER CHANGE-OVER SW.....	1.....	M92000010
3	M9520000204	DECAL: VOLTMETER CHANGE-OVER SW.....	1.....	M92000020
4	M1551000003	DECAL: GENERATOR CONTROL .....	1.....	M15100000
5	M9520100704	DECAL: WARNING ARC FLASH.....	1.....	M92010070
6	M9520100304	DECAL: GENERAL CAUTIONS.....	1.....	M92010030
7	M9520100004	DECAL: WARNING ELECTRICAL SHOCK.....	2.....	M92010000
8	M9520200404	DECAL: O.C.R. RESET.....	1.....	M92020040
9	M9520200003	DECAL: CONNECTION OF OUTPUT CABLE ..	1.....	M92020000
10	M9520000004	DECAL: GROUNDING.....	2.....	M92000000
11	M9520100404	DECAL: DANGER HIGH VOLTAGE .....	1.....	M92010040
12	M9520100204	DECAL: CAUTION CHANGE-OVER SW. ....	1.....	M92010020A
13	M9500300104	DECAL: + .....	1.....	M90030010
14	M9500300004	DECAL: - .....	1.....	M90030000
15	M9503100004	DECAL: WARNING RADIATOR CAP.....	1.....	M90310000
16	M9500100004	DECAL: WATER.....	1.....	M90010000
17	M9510100004	DECAL: CAUTION HIGH TEMP. ....	1.....	M91010000
18	M9503200004	DECAL: WARNING EXHAUST GAS.....	1.....	M90320000
19	M9503000004	DECAL: WARNING ROTATING PART .....	2.....	M90300000
20	M1561100703	STRIPE	1	
21	M1561101604	STRIPE	2	
22	M1561100804	STRIPE	1	
23	M1561100903	STRIPE	1	
24	M1561101004	STRIPE	2	
25	M1561101803	STRIPE	1	
26	M1561101904	STRIPE	1	
27	M9520100603	DECAL: WARNING AUTO START .....	2.....	M92010060
28	M1551000404	DECAL: NOTE LOAD SHARING .....	1.....	M15100040
29	M9503000103	DECAL: DAILY CHECK WATER AND OIL .....	1.....	M90300010
30	M9520000504	DECAL: START CONTACT .....	1.....	M92000050
31	M9520100503	DECAL: WARNING .....	1.....	M92010050
32	M9511100104	DECAL: NOTE RECEPTACLE.....	1.....	M91110010
33	M1551001003	DECAL: AUXILIARY OUTPUT.....	1.....	M15100100
34	M9510100403	DECAL: WARNING BATTERY CONNECT .....	1.....	M91010040
35	M9501500004	DECAL: DIESEL FUEL .....	1.....	M90150000
36	M9500000004	DECAL: OIL DRAIN .....	1.....	M90000000
37	M9510000104	DECAL: DOCUMENT BOX LOCATED .....	1.....	M91000010
38	M9511100004	DECAL: WARNING ENVIRONMENTAL.....	1.....	M91110000
39	M9503200104	DECAL: DANGER EX. GAS (INDOOR).....	1.....	M90320010
40	920214100	DECAL: WARNING START FIRES .....	1.....	REPLACES P/N M9504200004
41	M2550002303	OPERATING PRECAUTIONS .....	1.....	M25000230
42	M9510000004	DECAL: FLUID DRAIN.....	1.....	M91000000
43	M1550001404	CAUTION: LIFTING CAPACITY.....	1.....	M15000140
44	M9510200002	STICKER: MQ.....	1.....	M91020000
45	0600500092	EMBLEM	1	
46	0021106015	MACHINE SCREW	4	
47	M9511200103	TIER 4F.....	1.....	M91120010

# TERMS AND CONDITIONS OF SALE — PARTS

## PAYMENT TERMS

Terms of payment for parts are net 30 days.

## FREIGHT POLICY

All parts orders will be shipped collect or prepaid with the charges added to the invoice. All shipments are F.O.B. point of origin. Multiquip's responsibility ceases when a signed manifest has been obtained from the carrier, and any claim for shortage or damage must be settled between the consignee and the carrier.

## MINIMUM ORDER

The minimum charge for orders from Multiquip is \$15.00 net. Customers will be asked for instructions regarding handling of orders not meeting this requirement.

## RETURNED GOODS POLICY

Return shipments will be accepted and credit will be allowed, subject to the following provisions:

1. A Returned Material Authorization must be approved by Multiquip prior to shipment.
2. To obtain a Return Material Authorization, a list must be provided to Multiquip Parts Sales that defines item numbers, quantities, and descriptions of the items to be returned.
  - a. The parts numbers and descriptions must match the current parts price list.
  - b. The list must be typed or computer generated.
  - c. The list must state the reason(s) for the return.
  - d. The list must reference the sales order(s) or invoice(s) under which the items were originally purchased.
  - e. The list must include the name and phone number of the person requesting the RMA.
3. A copy of the Return Material Authorization must accompany the return shipment.
4. Freight is at the sender's expense. All parts must be returned freight prepaid to Multiquip's designated receiving point.

5. Parts must be in new and resalable condition, in the original Multiquip package (if any), and with Multiquip part numbers clearly marked.
6. The following items are not returnable:
  - a. Obsolete parts. (If an item is in the price book and shows as being replaced by another item, it is obsolete.)
  - b. Any parts with a limited shelf life (such as gaskets, seals, "O" rings, and other rubber parts) that were purchased more than six months prior to the return date.
  - c. Any line item with an extended dealer net price of less than \$5.00.
  - d. Special order items.
  - e. Electrical components.
  - f. Paint, chemicals, and lubricants.
  - g. Decals and paper products.
  - h. Items purchased in kits.
7. The sender will be notified of any material received that is not acceptable.
8. Such material will be held for five working days from notification, pending instructions. If a reply is not received within five days, the material will be returned to the sender at his expense.
9. Credit on returned parts will be issued at dealer net price at time of the original purchase, less a 15% restocking charge.
10. In cases where an item is accepted, for which the original purchase document can not be determined, the price will be based on the list price that was effective twelve months prior to the RMA date.
11. Credit issued will be applied to future purchases only.

## PRICING AND REBATES

Prices are subject to change without prior notice. Price changes are effective on a specific date and all orders received on or after that date will be billed at the revised price. Rebates for price declines and added charges for price increases will not be made for stock on hand at the time of any price change.

Multiquip reserves the right to quote and sell direct to Government agencies, and to Original Equipment Manufacturer accounts who use our products as integral parts of their own products.

## SPECIAL EXPEDITING SERVICE

A \$35.00 surcharge will be added to the invoice for special handling including bus shipments, insured parcel post or in cases where Multiquip must personally deliver the parts to the carrier.

## LIMITATIONS OF SELLER'S LIABILITY

Multiquip shall not be liable hereunder for damages in excess of the purchase price of the item with respect to which damages are claimed, and in no event shall Multiquip be liable for loss of profit or good will or for any other special, consequential or incidental damages.

## LIMITATION OF WARRANTIES

No warranties, express or implied, are made in connection with the sale of parts or trade accessories nor as to any engine not manufactured by Multiquip. Such warranties made in connection with the sale of new, complete units are made exclusively by a statement of warranty packaged with such units, and Multiquip neither assumes nor authorizes any person to assume for it any other obligation or liability whatever in connection with the sale of its products. Apart from such written statement of warranty, there are no warranties, express, implied or statutory, which extend beyond the description of the products on the face hereof.

Effective: February 22, 2006



# OPERATION AND PARTS MANUAL

## HERE'S HOW TO GET HELP

PLEASE HAVE THE MODEL AND SERIAL  
NUMBER ON-HAND WHEN CALLING

### UNITED STATES

#### ***Multiquip Corporate Office***

18910 Wilmington Ave.  
Carson, CA 90746  
Contact: mq@multiquip.com

Tel. (800) 421-1244  
Fax (310) 537-3927

#### ***Service Department***

800-421-1244  
310-537-3700

Fax: 310-537-4259

#### ***Technical Assistance***

800-478-1244

Fax: 310-943-2238

#### ***MQ Parts Department***

800-427-1244  
310-537-3700

Fax: 800-672-7877  
Fax: 310-637-3284

#### ***Warranty Department***

800-421-1244  
310-537-3700

Fax: 310-943-2249

---

### CANADA

#### ***Multiquip***

4110 Industriel Boul.  
Laval, Quebec, Canada H7L 6V3  
Contact: jmartin@multiquip.com

Tel: (450) 625-2244  
Tel: (877) 963-4411  
Fax: (450) 625-8664

---

### UNITED KINGDOM

#### ***Multiquip (UK) Limited Head Office***

Unit 2, Northpoint Industrial Estate,  
Globe Lane,  
Dukinfield, Cheshire SK16 4UJ  
Contact: sales@multiquip.co.uk

Tel: 0161 339 2223  
Fax: 0161 339 3226

© COPYRIGHT 2015, MULTIQUIP INC.

Multiquip Inc, the MQ logo and the MQ Power logo are registered trademarks of Multiquip Inc. and may not be used, reproduced, or altered without written permission. All other trademarks are the property of their respective owners and used with permission.

This manual MUST accompany the equipment at all times. This manual is considered a permanent part of the equipment and should remain with the unit if resold.

The information and specifications included in this publication were in effect at the time of approval for printing. Illustrations, descriptions, references and technical data contained in this manual are for guidance only and may not be considered as binding. Multiquip Inc. reserves the right to discontinue or change specifications, design or the information published in this publication at any time without notice and without incurring any obligations.

Your Local Dealer is:

Manufactured for  
Multiquip Inc.  
by  
DENYO CO., LTD, JAPAN

