



Installation manual

**CM20-25 commercial mobile
diesel generator sets with PCC 1302**

Manufactured in De Pere, Wisconsin

CALIFORNIA

Proposition 65 Warning

Diesel engine exhaust and some of its constituents are known to the State of California to cause cancer, birth defects, and other reproductive harm.

This manual contains proprietary information to equipment produced by Cummins Inc. and is being supplied solely for the purpose of installing the diesel generator set purchased from the Cummins facility in De Pere, Wisconsin. For warranty information, please visit our website at cummins.com.



This product has been manufactured under the controls established by a Bureau Veritas Certification approved management system that conforms with ISO 9001:2015.

Table of Contents

1 - IMPORTANT SAFETY INSTRUCTIONS

1.1 Warning, caution, and note styles used in this manual	1
1.2 General information	1
1.3 Electrical cautions.	3
1.4 Fuel hazards.	3
1.5 Battery hazards	3
1.6 Personal safety.	4
1.7 Exhaust gas precautions	4
1.8 Carbon monoxide hazards	5

2 - Introduction

2.1 About this manual.	7
2.2 Related literature	7
2.3 Before installation	8
2.4 Model specifications	8

3 - Pre-installation considerations

3.1 Installation codes and standards for safety	13
3.2 Required Items for Installation	14

4 - Installation

4.1 Introduction.	15
4.2 Site assessment and preparation	15
4.2.1 Choosing a location	15
4.2.2 Providing for clearance	15
4.2.3 Lifting and moving the generator set.	16
4.2.4 Mounting the generator set.	16
4.3 Fuel connections	16
4.3.1 Fuel lines routing.	17
4.3.2 Diesel fuel piping requirements.	17
4.3.3 Generator set fuel connections.	19
4.3.4 Fuel tank connections.	19
4.4 Exhaust connections	20
4.5 Electrical connections.	20
4.5.1 AC Connections	20
4.5.2 Battery connections	22
4.5.3 HMI connection.	23

5 - Startup and configuration

5.1 Installation checklist	25
5.2 Startup	26

6 - Outline and system drawings

This page is intentionally left blank.

1 - IMPORTANT SAFETY INSTRUCTIONS



SAVE THESE INSTRUCTIONS. These important instructions should be followed during installation, operation and maintenance of the generator set and batteries.

Safe and efficient operation can be achieved only if the equipment is properly operated and maintained. Many accidents are caused by failure to follow fundamental rules and precautions.

1.1 Warning, caution, and note styles used in this manual

The following safety styles and symbols found throughout this manual indicate potentially hazardous conditions to the operator service personnel, or equipment.

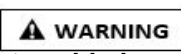
  
Indicates a hazardous situation that, if not avoided, will result in death or serious injury.

  
Indicates a hazardous situation that, if not avoided, could result in death or serious injury.

  
Indicates a hazardous situation that, if not avoided, could result in minor or moderate injury.

NOTE: *Indicates information considered important, but not hazard-related (e.g., messages relating to property damage).*



1.2 General information

This manual should form part of the documentation package supplied by Cummins Inc. with specific generator sets. If this manual has been supplied in isolation, please contact your authorized dealer.

NOTE: *It is in the operator's interest to read and understand all warnings and cautions contained in the documentation relevant to the generator set operation and daily maintenance.*

General safety precautions:

  
Hot Pressurized Liquid - Contact with hot liquid can cause severe burns. Do not open the pressure cap while the engine is running. Let the engine cool down before removing the cap. Turn the cap slowly and do not open it fully until the pressure has been relieved.

  
Moving Parts - Moving parts can cause severe personal injury. Use extreme caution around moving parts. All guards must be properly fastened to prevent unintended contact.

  
Toxic Hazard - Used engine oils have been identified by some state and federal agencies to cause cancer or reproductive toxicity. Do not ingest, breathe the fumes, or contact used oil when checking or changing engine oil. Wear protective gloves and face guard.

IMPORTANT SAFETY INSTRUCTIONS

⚠ WARNING

Electrical Generating Equipment - Incorrect operation and maintenance can result in severe personal injury or death. Do not operate equipment when fatigued, or after consuming any alcohol or drug. Make sure that only suitably trained and experienced service personnel perform electrical and/or mechanical service.

⚠ WARNING

Toxic Gases - Substances in exhaust gases have been identified by some state and federal agencies to cause cancer or reproductive toxicity. Do not breathe in or come into contact with exhaust gases.

⚠ WARNING

High Noise Level - Generator sets in operation emit noise, which can cause hearing damage. Wear appropriate ear protection at all times.

⚠ WARNING

Hot Surfaces - Contact with hot surfaces can cause severe burns. The unit is to be installed so that the risk of hot surface contact by people is minimized. Wear appropriate PPE when working on hot equipment and avoid contact with hot surfaces.

⚠ WARNING

Toxic Hazard - Ethylene glycol, used as an engine coolant, is toxic to humans and animals. Wear appropriate PPE. Clean up coolant spills and dispose of used coolant in accordance with local environmental regulations.

⚠ WARNING

Combustible Liquid - Ignition of combustible liquids is a fire or explosion hazard which can cause severe burns or death. Do not store fuel, cleaners, oil, etc., near the generator set. Do not use combustible liquids like ether.

⚠ WARNING

Combustible Gases - Generator sets in operation have combustible gases under pressure, which if ignited can cause eye and ear damage. Wear appropriate eye and ear protection at all times.

⚠ WARNING

Combustible Gases - Generator sets in operation have combustible gases under pressure, which if ignited can cause severe injury. Do not operate the generator set with any doors open.

⚠ WARNING

Fire Hazard - Materials drawn into the generator set, as well as accumulated grease and oil, are a fire hazard. Fire can cause severe burns or death. Keep the generator set and the surrounding area clean and free from obstructions. Make sure the generator set is mounted in a manner to prevent combustible materials from accumulating under the unit.

⚠ WARNING

Automated Machinery - Accidental or remote starting of the generator set can cause severe personal injury or death. Isolate all auxiliary supplies and use an insulated wrench to disconnect the starting battery cables (negative [-] first).

NOTE: Keep multi-type ABC fire extinguishers close by. Class A fires involve ordinary combustible materials such as wood and cloth. Class B fires involve combustible and flammable liquid fuels and gaseous fuels. Class C fires involve live electrical equipment. (Refer to NFPA No. 10 in the applicable region.)

NOTE: Before performing maintenance and service procedures on enclosed generator sets, make sure the service access doors are secured open.

NOTE: Stepping on the generator set can cause parts to bend or break, leading to electrical shorts, or to fuel, coolant, or exhaust leaks. Do not step on the generator set.

1.3 Electrical cautions

GenSet voltage is deadly. Generator set output connections must be made by a trained and experienced electrician in accordance with all applicable codes.



Improper connections can lead to electrocution of utility workers and damage to equipment. Make sure that the connections are installed properly by a trained technician.

Use caution when working on live electrical equipment. Remove jewelry, and make sure clothing and shoes are dry. Stand on a dry wooden platform.

1.4 Fuel hazards

Fuel and fumes are flammable. Fire, explosion, and personal injury or death can result from improper practices. To prevent an accident:

- Do not fill fuel tanks while the engine is running unless the tanks are outside the engine compartment. Fuel contact with hot engine or exhaust is a potential fire hazard.
- Do not permit any flame, cigarette, pilot light, spark, arcing equipment, or other ignition source near the generator set or fuel tank.
- Fuel lines must be adequately secured and free of leaks. Fuel connection at the generator set should be made with a flexible line approved for use with diesel fuel. Do not use copper piping on flexible lines as copper will become brittle if continuously vibrated or repeatedly bent.

1.5 Battery hazards

Batteries can explode, causing severe skin and eye burns and can release toxic electrolytes. Practice good safety with regard to batteries:

- Wear safety glasses.
- Do not smoke.
- Do not charge frozen batteries.
- Make sure the battery area has been well-ventilated prior to servicing near it. Lead-acid batteries emit a highly explosive hydrogen gas that can be ignited by arcing, sparking, smoking, etc.



Combustible Gases - Batteries can explode, causing severe skin and eye burns, and can release toxic electrolytes. Do not dispose of the battery in a fire, because it is capable of exploding. Do not open or mutilate the battery. Do not charge frozen batteries.

IMPORTANT SAFETY INSTRUCTIONS

 **WARNING**

Electric Shock Hazard - Batteries present the risk of high short circuit current. When servicing the generator set: remove watches, rings, or other metal objects. Use tools with insulated handles.

NOTE: Servicing of batteries must be performed or supervised by personnel knowledgeable of batteries and the required precautions. Keep unauthorized personnel away from batteries.

To prevent arcing when disconnecting the battery:

- a. Press the **Off** switch from the display.
- b. Disconnect AC power from any battery chargers.
- c. Remove the negative (-) battery cable.
- d. Remove the positive (+) battery cable.

To prevent arcing when connecting the battery:

- a. Connect the positive (+) cable.
- b. Connect the negative (-) cable.
- c. Connect the battery charger to AC power supply.

When replacing the generator set battery, always replace it with a battery as specified in this manual.

1.6 Personal safety

Moving parts can cause severe personal injury or death. Ensure personal safety when in the area of moving parts:

- Do not wear loose clothing or jewelry near moving parts, such as cooling fans.
- Keep hands away from moving parts.
- Keep guards in place over fans.

1.7 Exhaust gas precautions

Exhaust gases are deadly. Expel discharged gases away from enclosed or sheltered areas, and areas where individuals are likely to congregate. Visually and audibly inspect the exhaust system daily for leaks per the maintenance schedule. Make sure that exhaust manifolds are secured and not warped. Do not use exhaust gases to heat a compartment.

Make sure the unit is well-ventilated.

 **WARNING**

Hot Exhaust Gases - Contact with hot exhaust gases can cause severe burns. Wear personal protective equipment when working on equipment.

⚠ WARNING

Hot Surfaces - Contact with hot surfaces can cause severe burns. The unit is to be installed so that the risk of hot surface contact by people is minimized. Wear appropriate PPE when working on hot equipment and avoid contact with hot surfaces.

⚠ WARNING

Toxic Gases - Inhalation of exhaust gases can cause asphyxiation and death. Pipe exhaust gas outside and away from windows, doors, or other inlets to buildings. Do not allow exhaust gas to accumulate in habitable areas.

⚠ WARNING

Fire Hazard - Contaminated insulation is a fire hazard. Fire can cause severe burns or death. Remove any contaminated insulation and dispose of it in accordance with local regulations.

The exhaust outlet may be sited at the top or bottom of the generator set. Make sure that the exhaust outlet is not obstructed. Personnel using this equipment must be made aware of the exhaust position. Position the exhaust away from flammable materials - in the case of exhaust outlets at the bottom, make sure that vegetation is removed from the vicinity of the exhaust.

The exhaust pipes may have some fitted insulating covers. If these covers become contaminated they must be replaced before the generator set is run.

To minimize the risk of fire, make sure that the engine is allowed to cool thoroughly before performing maintenance or operation tasks.

1.8 Carbon monoxide hazards

Carbon monoxide (CO) is hazardous. CO is an odorless, colorless, tasteless and non-irritating gas. You cannot see it or smell it. Red blood cells, however, have a greater affinity for CO than for oxygen. Therefore, exposure even to low levels of CO for a prolonged period can lead to asphyxiation (lack of oxygen) resulting in death. Mild effects of CO poisoning include eye irritation, dizziness, headaches, fatigue and the inability to think clearly. More extreme symptoms include vomiting, seizures and collapse.

Engine-driven generator sets produce harmful levels of carbon monoxide that can injure or kill you.

⚠ WARNING

Toxic Gases - Carbon monoxide (CO) gas can cause nausea, fainting, or death. Depending on air temperature and wind, CO can accumulate in the vicinity. To protect yourself and others from the dangers of CO poisoning, it is recommended that reliable, approved, and operable CO detector alarms are installed in proper locations as specified by their manufacturer.

To protect yourself from CO poisoning:

- Locate the generator set in an area where there are no windows, doors, or other access points into an occupied area.
- Make sure all CO detectors are installed and working properly.
- Pay attention for signs of CO poisoning.
- Check the exhaust system for corrosion, obstruction, and leaks every time you start the generator set and every eight hours when you run it continuously.

This page is intentionally left blank.

2 - Introduction

2.1 About this manual



Improper installation can result in severe personal injury, death and damage to equipment. The installation must comply with all applicable building codes (including project permits and inspections). The installer should be properly trained and licensed to perform electrical and mechanical equipment installations.

NOTE: *Manuals are updated from time to time to reflect changes in the equipment and its specifications. The most up-to-date version of this manual is found on the QuickServe website (<https://quickserve.cummins.com/info/index.html>).*

This manual is a guide for the installation of the generator set models listed on the front cover. Proper installation is essential for top performance, reliable operation, and safety. Read through this manual before starting the installation. This manual covers outdoor applications only; for other installations, refer to the T-030: Liquid-Cooled Generator Set Application manual available from your Cummins distributor.

See the generator set's specific operator manual for operation and maintenance and specific service manual for service.

Refer to the Model Specifications section for specific information about the system and its components.

Refer to the Outline and System Drawings appendix and the Wiring Diagrams appendix for specific information about installation and wiring connections.

2.2 Related literature

A generator set must be operated and maintained properly if you are to expect safe and reliable operation. The operator manual includes a maintenance schedule and a troubleshooting guide. The health and safety manual must be read in conjunction with the operator manual for the safe operation of the generator set. The literature provided with the generator set is as follows:

- Warranty statement (A042E778)
- Emissions component defect warranty statement (A048K395)
- Generator set installation manual (A058M278)
- Generator set operator manual (A058M279)

The relevant manuals appropriate to your generator set are also available. The documents below are in English:

- Kubota V2403-CR-TIE4 engine service manual (A058M772)
- Kubota V2403-CR-TIE4 engine operators manual (A058M771)
- Kubota V2403-CR-TIE4 engine diagnosis manual (A058M770)
- Kubota V2403-CR-TIE4 service specifications (A058M773)

- Kubota V2403-CR-TIE4 parts manual (A058M769)
- PowerCommand® 1302 controller owner's manual (900-0661)
- Application manual T-030 - for application information (A040S369)

2.3 Before installation

Before beginning the installation of the generator set, verify that the unit was correctly selected. Check the following features:

- Model
- Specifications
- Options
- Fuel supply

2.4 Model specifications

Table 2-1. MODEL VARIATIONS

	CM20	CM25
Engine	Kubota V2403-CR-TIE4	
Cylinder	4	
Hz	60	
RPM	1800	

Table 2-2. GENSET SIZE SPECIFICATIONS

Configuration	CM20	CM25
Open set	58 x 26 x 34 in. (1467 x 658 x 868 mm)	
Closed set	59 x 27 x 35 in. (1499 x 686 x 889 mm)	

Table 2-3. GENSET WEIGHT SPECIFICATIONS

Configuration	CM20	CM25
Open set	1228 pounds	
Closed set	1450 pounds	

Table 2-4. OIL RECOMMENDATIONS

	CM20	CM25
Temperature range	Oil specification: Oil viscosity changes in cold temperature as crystallization of the wax element contained in oil proceeds, and fluidity is finally lost. Wrong selection of oil cannot only increase resistance for cold starting but also affect lubrication of each part. Oils for low temperature, containing additives for lowering the pour point, should be used. Oil used in the engine should have API classification and proper SAE engine oil viscosity according to the ambient temperatures where the engine is operated. NOTE: The use of synthetic oil is not recommended. Lubricating oil recommendation - CJ-4 or CK-4	
Above 77 °F (25 °C)	10W-30 or 10W-40 or 15W-40	
Between 14 and 77 °F (-10 to 25 °C)	10W-30 or 10W-40 or 15W-40	
Below 14 °F (-10 °C)	10W-30 or 10W-40	

Table 2-5. ALTERNATOR SPECIFICATIONS 60 HZ, 1800 RPM

	CM20	CM25
Generator	Cummins, brushless, drip proof construction - double-sealed, pre-lubricated ball bearing	
Power (kVA) 1-phase/3-phase-prime	20	25
Rated voltages (V)	120/240, 1-Ph	
	120/208, 3-Ph	
	277/480, 3-Ph	

Table 2-6. FUEL CONSUMPTION

	CM20	CM25
Full load	1.75 gal/hr (6.62 L/hr)	2.18 gal/hr (8.25 L/hr)

Table 2-7. ENGINE SPECIFICATIONS

	CM20	CM25
Engine	Kubota V2403-CR-TIE4	
Aspiration	Turbocharged	
Displacement	2434 cm ³ (149 in ³)	
Compression ratio	16:1	
Lube oil capacity	10 qt. (9.5 L)	
Fuel	Diesel fuel: Meeting European Norm (EN) 590 or American Society of Testing and Materials (ASTM) D975 recommended.	
	Cetane Rating: Minimum recommended is 45. A rating greater than 50 is preferred, especially in low ambient temperatures below -4 °F (-20 °C) and elevations above 5000 ft (1500 m).	
	DO NOT USE fuels that have sulfur content greater than 0.0015% (15 ppm).	
	The use of ultra-low sulfur diesel fuel is mandatory for Interim Tier 4 and/or later standards compliant engines, when operated in US EPA regulated areas. Therefore, use No. 2-D S15 diesel fuel as an alternative to No.2-D, and use No. 1-D S15 diesel fuel as an alternative to No. 1-D for ambient temperature below 14 °F (-10 °C).	
	If the engine is to be operated within the European Union on diesel or non-road gas-oil, a fuel with sulfur content not greater than 10 mg/kg (20 mg/kg at point of final distribution), a cetane number not less than 45 and a fatty acid methyl ester (FAME) content not greater than 7% volume per volume (v/v) shall be used.	
Cooling system	2.75 gal. (10 L)	
Coolant	50/50 coolant solution (50% distilled or de-ionized water and 50% ethylene glycol)	
Exhaust	Maximum allowable back pressure at the turbocharger 51 in. H ₂ O (12.7 kPa)	
	Exhaust flow at rated load: 155 cfm (4.4 m ³ /min.)	
	Exhaust temperature: 932 °F (500 °C)	

Table 2-7. ENGINE SPECIFICATIONS

	CM20	CM25
Fuel connections	Fuel Supply: 1/4 in. female npt	
	Fuel Return: 1/4 in. female npt	
	See fuel restriction calculators in 4.3 Fuel connections .	

Table 2-8. GENERATOR SET DERATING GUIDELINES

	CM20	CM25
Prime	Engine power available up to 9514 ft (2900 m) and ambient temperatures up to 77 °F (25 °C). Above these conditions, derate at 1% per 100 m (328 ft) and 7% per 18 °F (10 °C).	Engine power available up to 8200 ft (2500 m) and ambient temperatures up to 77 °F (25 °C). Above these conditions, derate at 1% per 100 m (328 ft) and 7% per 18 °F (10 °C).

Table 2-9. DC SYSTEM SPECIFICATIONS

	CM20	CM25
Nominal battery voltage	12 VDC	
Minimum cold crank amps	830	

Table 2-10. COLD WEATHER STARTING SPECIFICATIONS

	CM20	CM25
Temperature range	Starting specifications	
Above -4 °F (-20 °C)	No starting aids required.	
Below -4 °F (-20 °C)	Coolant heater required. Factory option available.	

This page is intentionally left blank.

3 - Pre-installation considerations

Before installation begins, certain items must be considered. Prior coordination reduces delays and the amount of time power has to be interrupted. Areas of consideration include:

- Mounting area
- Physical location
- Fuel supply
- Adequate space for air movement
- Exhaust location
- Electrical connections
- Tools and materials required
- Access to serviceable items

NOTE: Depending on the locality and use of the generator set, it may be necessary to obtain an air quality emissions permit before installation begins. Check with local pollution control or air quality authority to determine permit requirements.

3.1 Installation codes and standards for safety

The following list of codes and standards may apply to the installation and operation of the generator set. This list is for reference only and not intended to be inclusive of all applicable codes and standards. The address of each agency is listed so that copies of the codes may be obtained for reference. Installation codes and recommendations are subject to change, and may vary by location or over time.

Table 3-1. INSTALLATION CODES AND STANDARDS FOR SAFETY RECOMMENDATIONS

Type	Code or Standard	Title	Organization
US	Code	NFPA 70 - National Electrical Code	National Fire Protection Association 470 Atlantic Avenue Boston, MA 02210
Canada	Code	CSA 22.1 Canadian Electrical Code	Canadian Standards Association Housing and Construction Materials Section 178 Rexdale Blvd. Rexdale, Ontario, Canada M9Q 1R3
California	Code	California Administrative Code - Title 25 Chapter 3	State of California Documents Section P.O.Box1015 North Highlands, CA 95660

NOTE: *The generator set installer bears sole responsibility for following all applicable local codes and regulations.*

3.2 Required Items for Installation

Along with this manual, the following documents and loose parts were included in the generator set shipment:

A042J775	EXHAUST TUBE
A057W108	REMOTE HMI HARNESS
900-0661	CONTROL MANUAL
300-6014	REMOTE HMI
A057W017	GENSET INSTALLATION REVIEW FORM
MISC	MISC PAPERWORK/KUBOTA BOM
A062Z711	ALTERNATOR MANUAL A040J847

NOTE: *Refer to local codes and standards, which may affect the material requirements.*

The installation requires:

- Four base 1/2"-13 (for threaded mounting holes) or 3/8" (for thru holes) tie-down bolts (see [6 - Outline and system drawings](#)). The length of the bolts to be determined by the mounting structure.
- Flexible fuel lines and fittings
- Battery and battery cables

4 - Installation

4.1 Introduction

NOTE: *The installer is responsible for complying with all applicable installation codes and safety requirements. See the Installation Codes and Standards for Safety section of this manual for more information.*

The following sections cover a step-by-step overview of a typical generator set installation.

Review these sections to become familiar with specific procedures and important safety precautions before beginning the installation.

4.2 Site assessment and preparation

Proper component location and site preparation have a very important impact on completing a successful installation. The major components needed for installation include the following items:

- Generator set
- Fuel source (diesel)
- Batteries and battery cables
- Accessories (may be required based on certain conditions)

4.2.1 Choosing a location



Exhaust gas is deadly. Locate the generator set away from doors, windows, and other openings.

Support the generator set on a structure able to resist the dynamic weight of the generator set: ± 3 g-force vertical and ± 3 g-force horizontal. Refer to [Table 2-3. GENSET WEIGHT SPECIFICATIONS](#) for the weight of the generator set. Use four Grade 5 bolts to secure the generator set frame to the mounting structure. Torque the bolts to SAE standards. Generator set location is critical for safety and performance:

- The installation must comply with applicable codes (NFPA, NEC, etc.).
- This manual only covers outdoor installations with and without Cummins factory installed enclosures.

4.2.2 Providing for clearance

Adhere to the following clearance guidelines:

- Position the generator set so that cooling air is free to enter and leave the area. Ensure a minimum of 2" clearance around the generator set with the mounting area able to support 4000 cfm of fresh air flow to/from the generator set.
- The generator set must be located to ensure ventilation openings are not blocked.
- The exhaust side of the generator set must be located at a minimum of 5 feet from combustible materials (NFPA 37) and any opening in a wall (window, door, vent, etc.).

- The generator set must be located such that the exhaust is not able to accumulate in an occupied area.
- The generator set must have enough room for installation, service, and maintenance.

4.2.3 Lifting and moving the generator set

Lift the generator set by all four designated lifting points only.

⚠ WARNING

Heavy Load - The generator set is heavy. Handle with care. Dropping the generator set can cause severe personal injury or death. Use appropriate lifting techniques to move the generator set. Keep feet and hands clear when lifting the generator set.

⚠ CAUTION

The generator set is shipped with oil in the engine crankcase. Keep the generator set upright.

4.2.4 Mounting the generator set

Mount the generator set on a substantial and level base. A non-combustible material must be used for the pad. Verify that the mounting pad is level by length, by width, and diagonally. Level the generator set from side-to-side within ± 1 in. (25 mm), and end-to-end within ± 1 in. (25 mm).

4.3 Fuel connections

In all fuel system installations, cleanliness is of the utmost importance. Make every effort to prevent entrance of moisture, dirt, or contaminants of any kind into the fuel system. Clean all fuel system components before installing. Make every effort to prevent fuel contamination from:

- Moisture
- Dirt
- Excess thread sealant
- Contaminants of any kind

Clean all fuel system components before installing.

NOTE: *Never use galvanized or copper fuel lines, fittings, or fuel tanks. Condensation in the tank and lines combines with the sulfur in diesel fuel to produce sulfuric acid. The molecular structure of the copper or galvanized lines or tanks reacts with the acid and contaminates the fuel, resulting in engine damage.*

It is recommended that a positive fuel shutoff valve (ball) be installed on the fuel supply tank.

NOTE: *Never install a shutoff device in fuel return line(s). If fuel return line(s) is blocked or exceeds fuel restriction limit, engine damage can occur.*

For fuel specifications, see [2.4 Model specifications](#).

NOTE: *Improper installation presents hazards of fire and improper operation, resulting in severe personal injury or property damage.*

⚠ WARNING

Do not mix gasoline, alcohol, or gasohol with diesel fuel. This can cause an explosion.

CAUTION

Due to the precise tolerances of diesel injection systems, it is extremely important that the fuel be kept clean and free from dirt or water. Dirt or water in the system can cause severe damage to both the fuel pump and fuel injectors.

4.3.1 Fuel lines routing

WARNING

Explosive hazard - Fuel leaks create fire and explosion hazards which can result in severe personal injury or death. Always use flexible tubing between the engine and fuel supply to avoid line failure and leaks due to vibration. The fuel system must meet all application codes.

WARNING

Sparks and hot surfaces - Sparks and hot surfaces can ignite fuel, leading to severe personal injury or death. Do not route fuel lines near electrical wiring or hot exhaust parts.

NOTE: Fuel lines must be routed and secured to maintain a 12.7 mm (½ inch) minimum clearance from electrical wiring and a 51 mm (2 inch) minimum clearance from hot exhaust parts.

A flexible fuel hose(s) or section of flexible fuel hose(s) must be used between the generator set's fuel supply and return connection(s) to protect the fuel system from damage caused by vibration, expansion, and contraction. Flexible lines for connecting between the generator set and the fuel tank are NOT included as standard equipment.

4.3.2 Diesel fuel piping requirements

Diesel fuel lines, if used, should be constructed from black iron or stainless steel pipe. Cast iron, brass, and aluminum pipe and fittings must not be used because they are porous and can leak fuel. Galvanized fuel lines, fittings, and tanks must not be used because the galvanized coating is attacked by the sulfuric acid that forms when the sulfur in the fuel combines with tank condensate, resulting in debris that can clog fuel pumps and filters. Copper lines should not be used because fuel polymerizes (thickens) in copper tubing during long periods of disuse and can clog fuel injectors. Also, copper lines are less rugged than black iron, and thus more susceptible to damage.

NOTE: Never use galvanized or copper fuel lines, fittings or fuel tanks. Condensation in the tank and lines combines with the sulfur in the diesel fuel to produce sulfuric acid. The molecular structure of the copper or galvanized lines or tanks reacts with the acid and contaminates the fuel.

Approved flexible fuel hose - compatible with diesel fuel - must be used for connections at the generator set fuel supply and return connections to take up generator set movement and vibration.

Fuel system plumbing should be properly supported to prevent vibration and breakage due to vibration. The plumbing should not run close to heating pipes, electrical wiring, or engine exhaust system components. The plumbing system design should include valves at appropriate locations to allow isolation of system components for repair without draining the entire fuel system.

Fuel plumbing systems should be regularly inspected for leaks and general condition. The plumbing system should be flushed before operation of the generator set to remove dirt and other impurities that could damage the engine.

The maximum fuel supply and restriction limits should not exceed the limits established within the calculation tables included in this manual - fuel supply and return hose and pipe sizes used within the fuel system should be sized accordingly, as engine performance and fuel system durability can be compromised if the restriction limits are not adhered to.

Installation

If the calculated restriction value exceeds the published limits, adjust the plumbing system as-needed to comply with the limits, or contact Cummins Sales and Service.

Fuel return lines must not contain a shutoff device, as engine damage (or personal injury) can result if the engine is run with the fuel return line blocked or restricted.

Fuel supply lines must be at least ¼ inch (6.35mm) ID. The restriction limit between the fuel supply (tank) and the genset fuel supply connection is **1.75 in. Hg**. Use the calculation table below to calculate the restriction of the fuel supply system for a particular installation:

Generator set fuel system SUPPLY restriction calculator

Input	Value	Units	Restriction per unit value	Total restriction
Vertical height from bottom of fuel tank to fuel supply connection on genset (on unit base) ¹		ft.	0.736 in Hg	____ in. Hg
Length of 1/4" fuel line		ft.	0.022 in Hg	____ in. Hg
Length of 5/16" fuel line		ft.	0.007 in Hg	____ in. Hg
Length of 3/8" fuel line		ft.	0.003 in Hg	____ in. Hg
Quantity of 1/4", 90° fittings		each	0.033 in Hg	____ in. Hg
Quantity of 5/16", 90° fittings		each	0.010 in Hg	____ in. Hg
Quantity of 3/8", 90° fittings		each	0.004 in Hg	____ in. Hg
Quantity of 1/4" straight fittings		each	0.022 in Hg	____ in. Hg
Quantity of 5/16" straight fittings		each	0.007 in Hg	____ in. Hg
Quantity of 3/8" straight fittings		each	0.002 in Hg	____ in. Hg
Supply line shutoff valve or check valve (if installed) ²		in. Hg	N/A	____ in. Hg
Sum of total restrictions = total system supply restriction ->				____ in. Hg

¹ The vertical height calculation assumes that the fuel tank is mounted under the generator set. If the fuel tank is mounted above the generator set, contact Cummins Sales and Service, as additional installation requirements may apply.

² Obtain the restriction value for the automatic shutoff valve or check valve from the component supplier. The restriction value should be based on a fuel flow rate of 0.34 gallons/minute (gpm).

Fuel return lines must be at least ¼ inch (6.35mm) ID. The restriction limit between the genset fuel return connection and the fuel tank is **6.0 in. Hg**. Use the calculation table below to calculate the restriction of the fuel return system for a particular installation:

Generator set fuel system RETURN restriction calculator

Input	Value	Units	Restriction per unit value	Total restriction
Vertical height from bottom of fuel tank to fuel return connection on genset (on unit base)*		ft.	-0.736 in Hg	____ in. Hg
Length of 1/4" fuel line		ft.	0.016 in Hg	____ in. Hg
Length of 5/16" fuel line		ft.	0.005 in Hg	____ in. Hg
Length of 3/8" fuel line		ft.	0.002 in Hg	____ in. Hg
Quantity of 1/4", 90° fittings		each	0.024 in Hg	____ in. Hg
Quantity of 5/16", 90° fittings		each	0.007 in Hg	____ in. Hg
Quantity of 3/8", 90° fittings		each	0.003 in Hg	____ in. Hg
Quantity of 1/4" straight fittings		each	0.016 in Hg	____ in. Hg
Quantity of 5/16" straight fittings		each	0.005 in Hg	____ in. Hg
Quantity of 3/8" straight fittings		each	0.002 in Hg	____ in. Hg
Sum of total restrictions = total system return restriction ->				____ in. Hg

* The vertical height calculation assumes that the fuel tank is mounted under the generator set. If the fuel tank is mounted above the generator set, contact Cummins Sales and Service, as additional installation requirements may apply.

4.3.3 Generator set fuel connections

The fuel supply line and fuel return line connections are identified on the generator set. All models require fuel supply and return lines from the generator set to the tank.

4.3.4 Fuel tank connections

The fuel tank should be located as closely as possible to the generator set and the "high" level of the fuel tank should be below the generator set fuel supply connection point. The fuel tank should have sufficient capacity to allow the generator set to operate continuously at full rated load for the planned period of operation.

▲ WARNING

Fuel spillage - Spilled fuel presents the hazard of fire or explosion which can result in severe personal injury or death.

4.4 Exhaust connections

The exhaust system for this generator set is complete and was designed specifically for this generator set. The only modification that may be made to the exhaust system is to install the optional 90° exhaust elbow that was included in the loose parts with the generator set shipment.

▲ WARNING

Exhaust gas is deadly. Make sure that the exhaust system terminates away from building vents, windows, doors, and sheltered spaces that may not have ample fresh air ventilation.

▲ WARNING

Engine discharge air and exhaust carry carbon monoxide gas (odorless and invisible) which can cause asphyxiation and death. Never use engine discharge air or exhaust for heating a room or enclosed space.

4.5 Electrical connections

▲ WARNING

Improper installation can lead to electrocution and damage to property. Electrical connections must be made by a licensed electrician.

▲ WARNING

Automatic startup of the generator set during installation can cause severe personal injury or death. Make sure the generator set is shut down and disabled.

NOTE: Refer to regional codes and the National Electrical Code (NFPA 70) for all electrical installation requirements.

4.5.1 AC Connections

▲ WARNING

Accidental or remote starting of the generator set can cause severe personal injury or death. Isolate all auxiliary supplies and use an insulated wrench to disconnect the starting battery cables, negative (-) cable first.

To terminate the AC connections at the circuit breaker:

1. Ensure the generator set is shut down and disabled.
2. Disconnect the negative (-) cable from the battery and secure it from contacting the battery terminals to prevent accidental starting.
3. Remove the enclosure rear panel (if applicable) and the rear breaker box panel to access the main circuit breaker box.
4. Place the circuit breaker handle in the **OFF** position.
5. Remove the four bolts holding the circuit breaker cover.

6. Locate and drill a hole in the access plate.

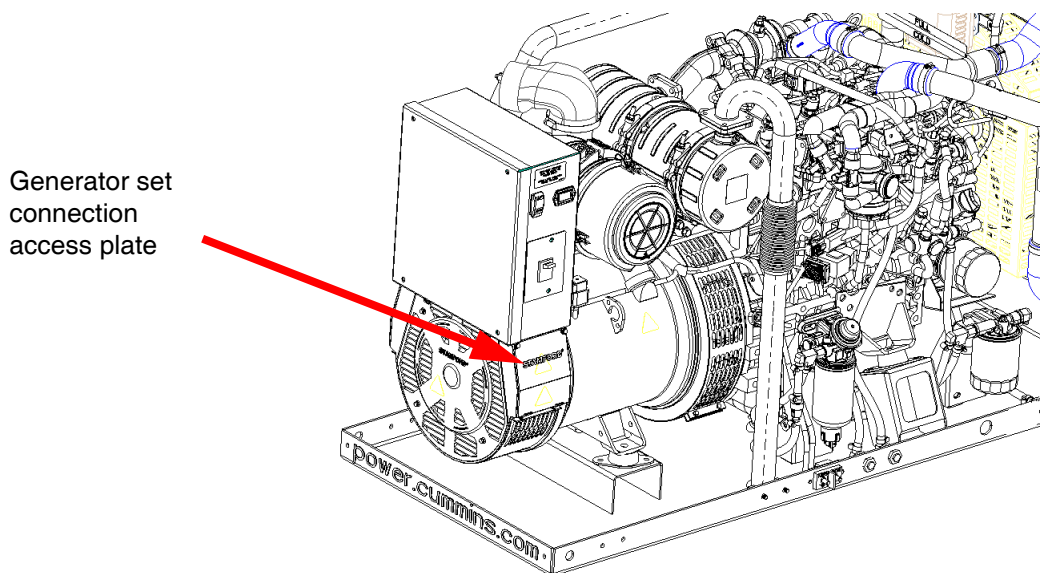

Figure 4-1 Location of hole in the access plate

7. Feed and connect the conductors to the circuit breaker load-side terminals, neutral lug, and equipment grounding lug. The grounding lug is identified with a decal and the neutral connection point is identified with a "N" on the generator connection block.

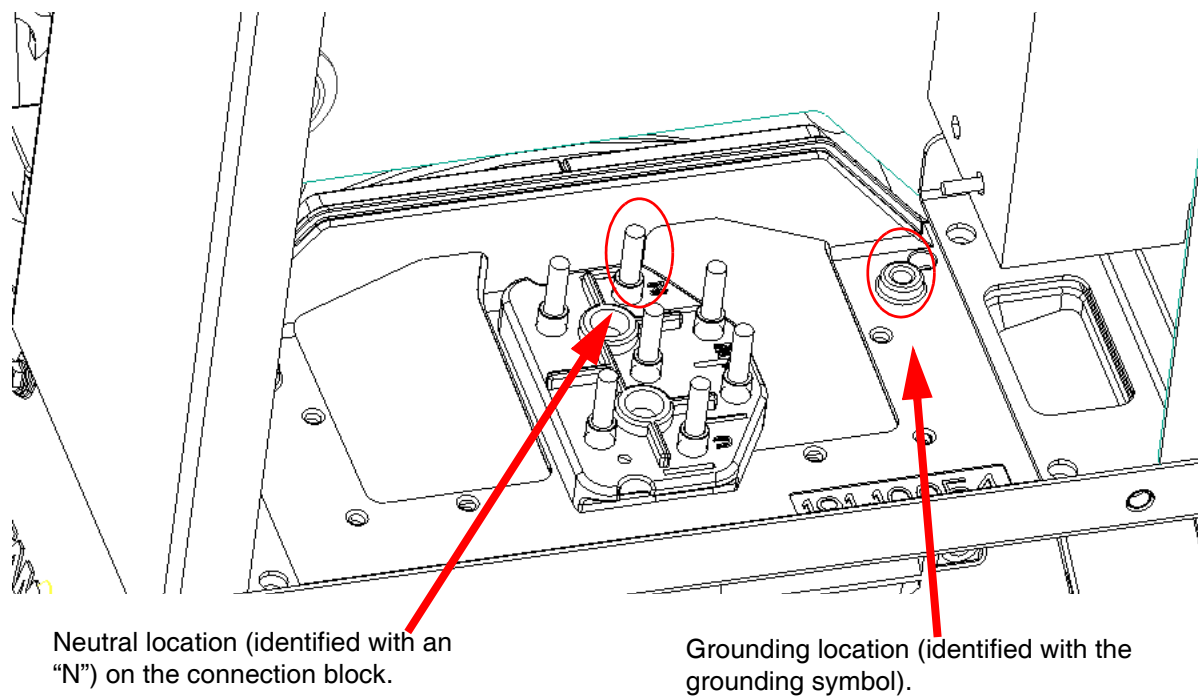

Figure 4-2 Circuit breaker AC load connections location (symbols shown at the bottom)

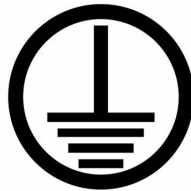

Figure 4-3 Grounding symbol

NOTE: *The generator set is shipped from the factory with the neutral and equipment ground not bonded together. Refer to local codes and standards for grounding procedures.*

8. Torque the circuit breaker terminals per specifications on the circuit breaker label.
9. Tighten the neutral lug.
10. Tighten the equipment grounding lug.
11. Install the circuit breaker cover, breaker box cover and the generator set enclosure rear panel (if applicable).

4.5.2 Battery connections

The generator set requires 12V battery (negatively-grounded) power for engine cranking and powering the electronic control system. When the generator set is running, the battery will be charged from the engine-driven alternator. Connect the 12V positive and negative battery connections to the battery connection block on the generator set and torque the connections to 70 in. lbs. Follow the table below for battery cable length requirements:

Table 4-1. Battery cable size for ambient temperatures to -20 °F (-29 °C)

Total cable length in feet (meters)	Cable size in AWG (mm ²)
0 to 15 (0 to 4.5)	1/0 (53)
16 to 25 (4.5 to 7.6)	3/0 (85)

Refer to the Model Specifications for battery specifications.

To prevent injury due to accidental startup, do not connect the battery cables to the battery until the installation has been completed; tools, rags, and body parts are away from any rotating parts or electrically live parts; and it is time to start the set.



Electrolyte is a dilute sulphuric acid that is harmful to the skin and eyes. It is electrically conductive and corrosive. Wear full eye protection and protective clothing. If electrolyte contacts the skins, wash it off immediately with water. If electrolyte contacts the eyes, flush thoroughly and immediately with water and seek medical attention. Wash spilled electrolyte with an acid neutralizing agent.

The battery connections are shown below. To connect the battery:

1. Connect the positive battery terminal.
2. Connect the negative battery terminal.

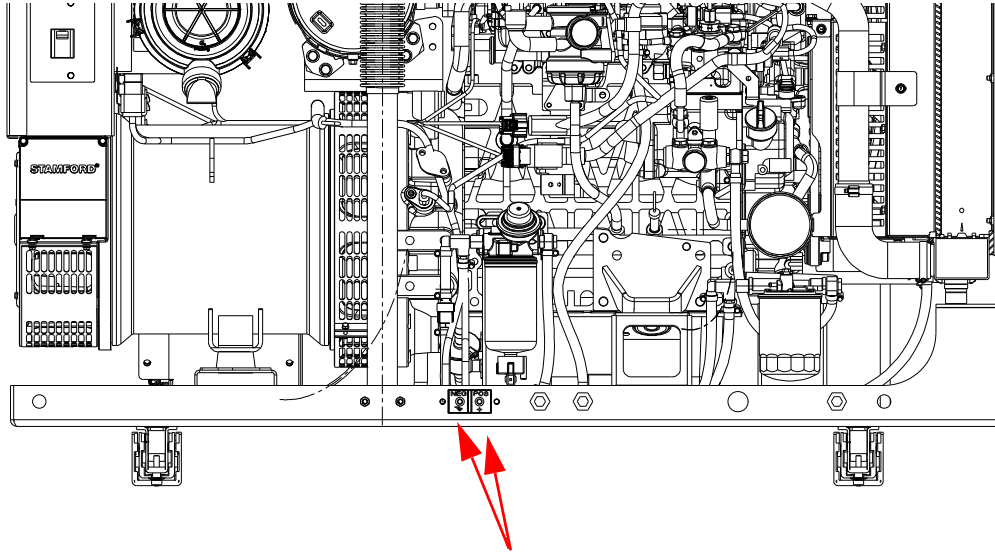

Figure 4-4 Battery connections

NOTE: *Wear proper safety protection when working around batteries. Keep open flames and sparks away from the equipment.*

NOTE: *Only personnel knowledgeable of batteries and required precautions should perform or supervise battery servicing.*

4.5.3 HMI connection

To connect the remote HMI:

1. Locate and determine the placement of the HMI to verify the cable length shipped with the generator set is adequate.
2. Install the HMI display (reference PowerCommand 1302 controller owner's manual (900-0661).
3. Feed the (generator set) end of the harness through the front of the generator set breaker box. Remove the rear breaker panel and connect the HMI harness to the HMI connector on the generator set.
4. Plug the other end of the harness into the HMI.

This page is intentionally left blank.

5 - Startup and configuration

Complete the installation checklist below prior to starting the generator set for the first time.

5.1 Installation checklist

Table 5-1. Installation checklist

Tick	
General items	
	Generator set wattage capacity is sufficient to handle maximum anticipated load.
	Adequate clearance is provided around the entire generator set for service and ventilation.
	The generator set is located in an area not subject to flooding.
	All operating personnel have read and are familiar with the generator set operator manual, all health and safety procedures, warnings, cautions, precautions, and the other documentation supplied with the generator set.
	All operators have been thoroughly briefed on preventative maintenance procedures.
	All operators have read and understand all important safety instructions.
Generator Set Support	
	The floor, roof, or earth on which the generator set rests is strong enough and will not allow shifting or movement. Observe local codes on soil bearing capacity due to freezing and thawing.
	The generator set is properly supported and retained to an approved base
Diesel Fuel System	
	Fuel tanks meet or exceed all local, state, or national codes (if applicable).
	Fuel lines are properly installed, supported, and protected against damage.
	No shutoff valves are installed on engine fuel return line.
	Fuel tanks are filled with the correct grade of fuel.
	Fuel system is properly primed.
	No fuel leaks are found in supply line or engine fuel system.
Exhaust System	
	Operators are thoroughly briefed on the dangers of carbon monoxide gas.
	Areas around generator set are well ventilated. No possibility of exhaust fumes entering building doors, windows, or intake fans.
	Exhaust gases are piped safely outside and away from doors, windows and openings.

Table 5-1. Installation checklist

Tick	
AC and DC Wiring	
	Wire sizes, insulation, conduits and connection methods all meet applicable codes.
	AC and DC wires are separated in their own conduit to prevent electrical induction.
	All load, line and generator connections are well made and correct.
Generator Set Pre-Start	
	Generator set engine is properly serviced with oil and coolant.
	Batteries are properly installed, serviced and charged.
	Engine coolant heater is connected and operational (if applicable).
	All generator set covers and safety shields are installed correctly.

⚠ WARNING

Automated Machinery - Accidental or remote starting of the generator set can cause severe personal injury or death. Isolate all auxiliary supplies and use an insulated wrench to disconnect the starting battery cables, negative (-) cable first.

5.2 Startup

After verifying that the installation was completed correctly, start and test the system.

With the fuel supply and return lines connected from the fuel tank to the generator set, and with all fuel shutoff valves (if equipped) in the "open" position, prime the fuel system to vent the air. Prime the system by using the priming bulb located on the fuel/water separator and vent the air by opening the vent screw on the top of the fuel filter.

IMPORTANT: *This procedure may need to be conducted by simultaneously cranking the engine and may need to be repeated several times in order remove all the air from the system.*

Contact your local Cummins service representative if you encounter a fault code.

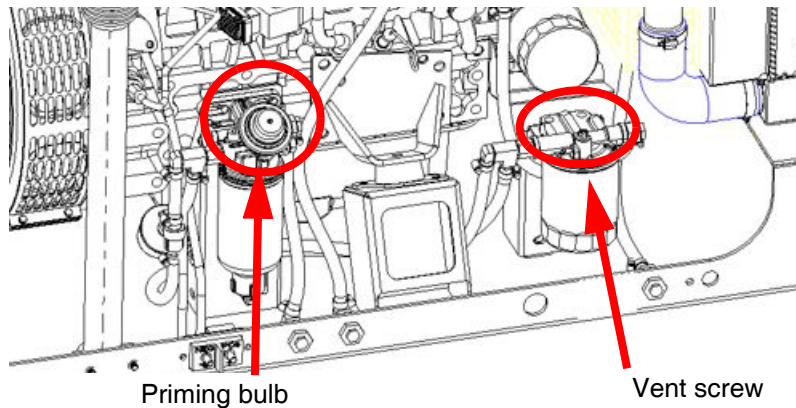

Figure 5-1 Generator set priming bulb and vent screw

6 - Outline and system drawings

Generator set diagram	Drawing No.
General assembly, GenSet open-set, w/slides, CM20-25	CM20_25-01
General assembly, GenSet closed-set, w/slides, CM20-25	CM20_25-02
Schematic, Controls Interface Commercial Mobile 20-25 kW w/PCC 1302	A042F537

This page is intentionally left blank.

GENSET MODELS		
UNIT	NEWAGE GENERATOR FRAME SIZE	TOTAL WEIGHT OF UNIT
CM20-1	P1144H	1228 lbs
CM20-2		
CM20-3		
CM25-1		
CM25-2		
CM25-3		

LEGACY GENSET MODELS			
UNIT	NEWAGE GENERATOR FRAME SIZE	DIMENSION "A"	TOTAL WEIGHT OF UNIT
CM20-1	P1144E	54.35"	1145 lbs
CM20-2	P1144E	54.35"	1145 lbs
CM20-3	P1144E	54.35"	1145 lbs
CM25-1	P1144F	54.94"	1164 lbs
CM25-2	P1144H	57.49"	1228 lbs
CM25-3	P1144F	54.94"	1164 lbs

FUEL SUPPLY	1/4" FNPT
FUEL RETURN	1/4" FNPT
COOLANT DRAIN	1/4" FNPT
POSITIVE BATTERY CONNECTION	5/16"-18 UNC
NEGATIVE BATTERY CONNECTION	5/16"-18 UNC
EXHAUST CONNECTION (ON ENGINE)	Ø 1.91"OD (48.6mm)
EXHAUST 90° OUTLET (SHIPPED LOOSE)	Ø 1.75"OD
ENGINE OIL CAPACITY	10 QUARTS
TOTAL COOLANT CAPACITY	5 GALLON

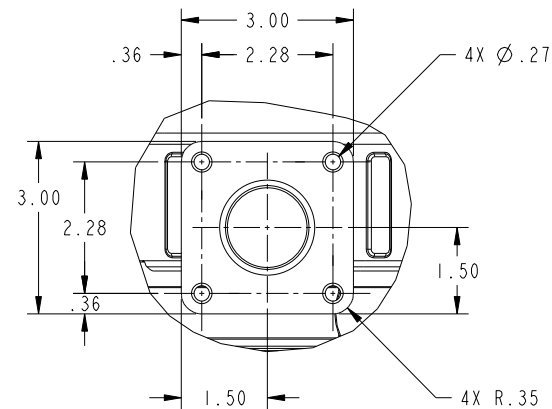

EXHAUST CONNECTION
DETAIL A
SCALE .625

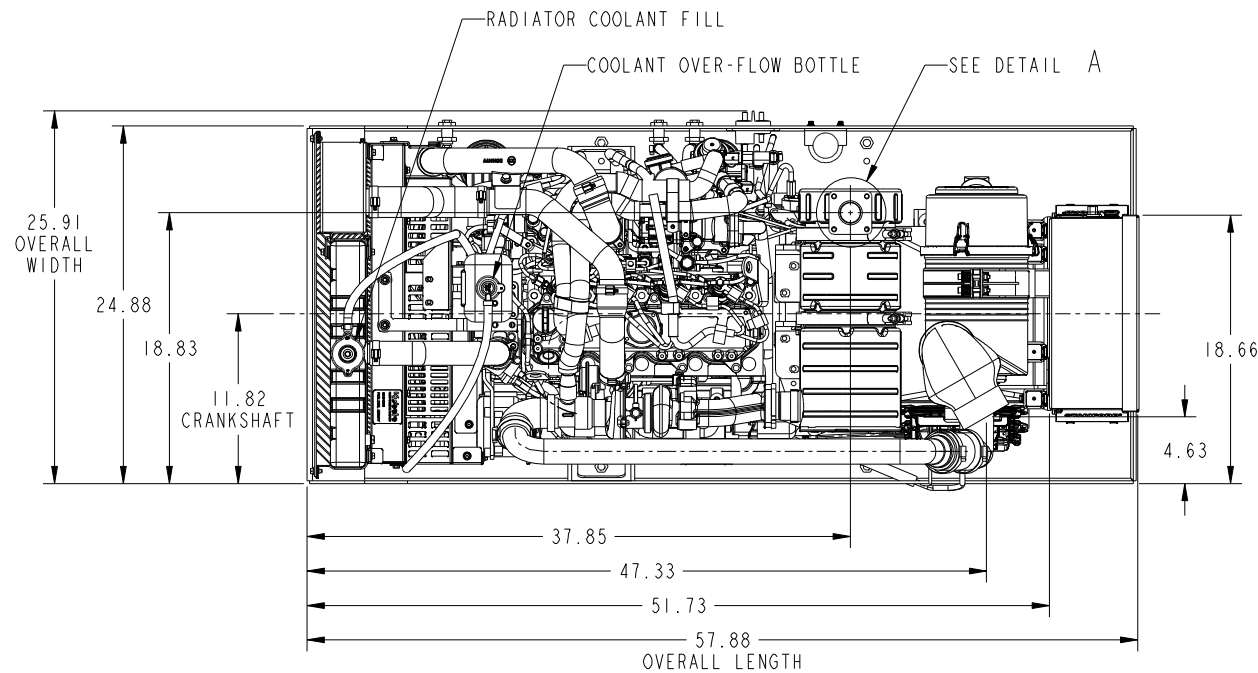
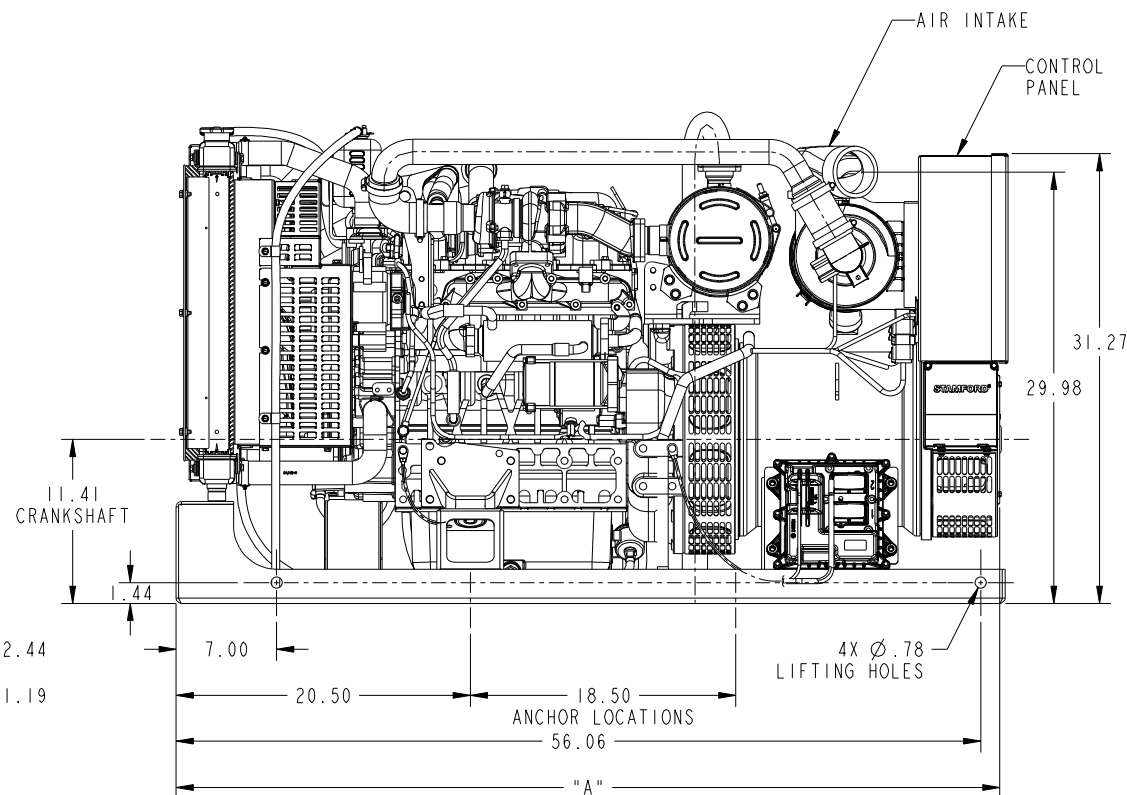
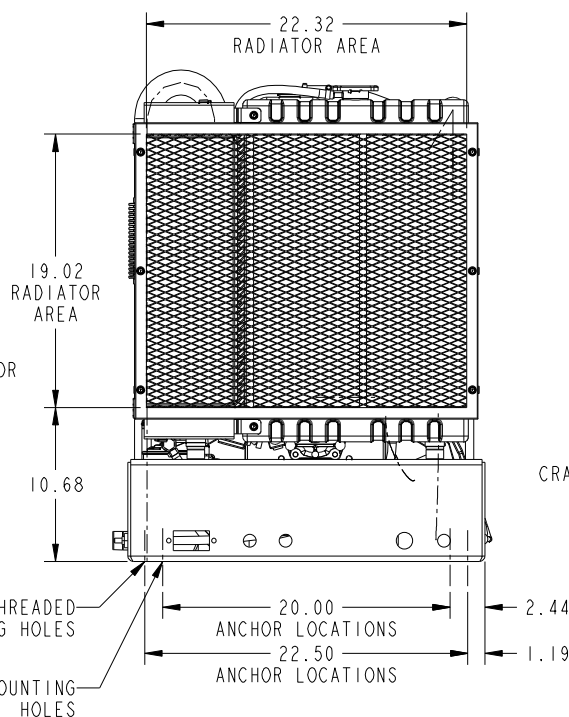
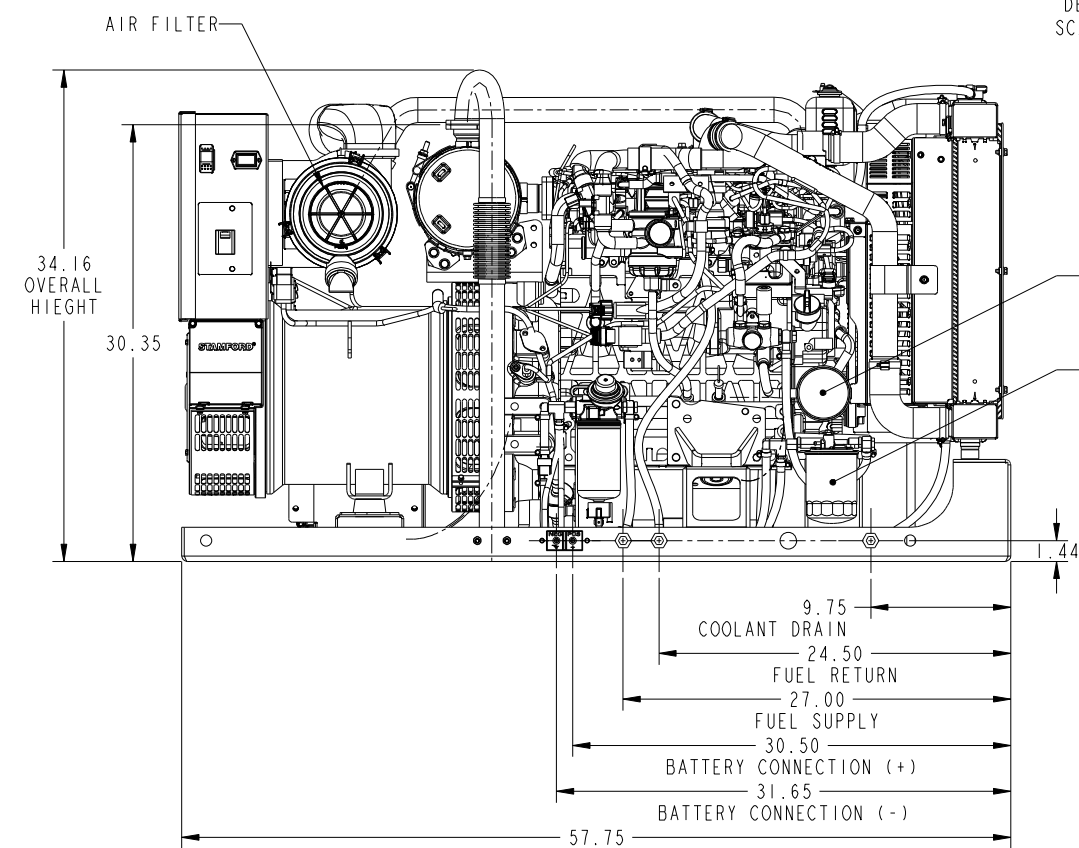

NOTES:
1. ALL WEIGHTS & DIMENSIONS ARE APPROXIMATE
2. SEE SHEET 2 FOR CM20-25 OPEN-SET UNIT W/ SLIDES

DIMENSIONS ARE IN: INCHES () ARE IN: MILLIMETERS	DO NOT SCALE PRINT	CMI DATA CLASSIFICATION Cummins Confidential		Cummins Inc.	
DRAWING TOLERANCES UNLESS OTHERWISE SPECIFIED: X: ± 1/16 OR 4 mm X.L: ± 1/16 OR 4 mm X.H: ± .010 IN OR 0.25 mm X.X: ± .010 IN OR 0.25 mm ANGULAR TOLERANCES: ± 1°	SCALE: .156	DWN: NO134 CKD: - APVD: LG956 DATE: 23AUG2018		ITEM NAME GENERAL ASSEMBLY, GENSET OPEN-SET, W/ SLIDES, CM20-25	ITEM NUMBER CM20_25-01
<small>THIS DOCUMENT AND THE INFORMATION SHOWN THEREON IS CONFIDENTIAL AND PROPRIETARY AND SHALL NOT BE DISCLOSED TO OTHERS IN HARD COPY OR ELECTRONIC FORM, REPRODUCED BY ANY MEANS, OR USED FOR ANY PURPOSE WITHOUT WRITTEN CONSENT OF CUMMINS INC.</small>			<small>MUST CONFORM TO CES 10903</small>		

REV	REL NO	REVISION	DWN	CKD	APVD	DATE
-	N/A	RELEASED TO PRODUCTION	NO134	-	LG956	15JUN17
A	2018-467	UPDATED PER GENSET REDESIGN	NO134	-	LG956	23AUG18

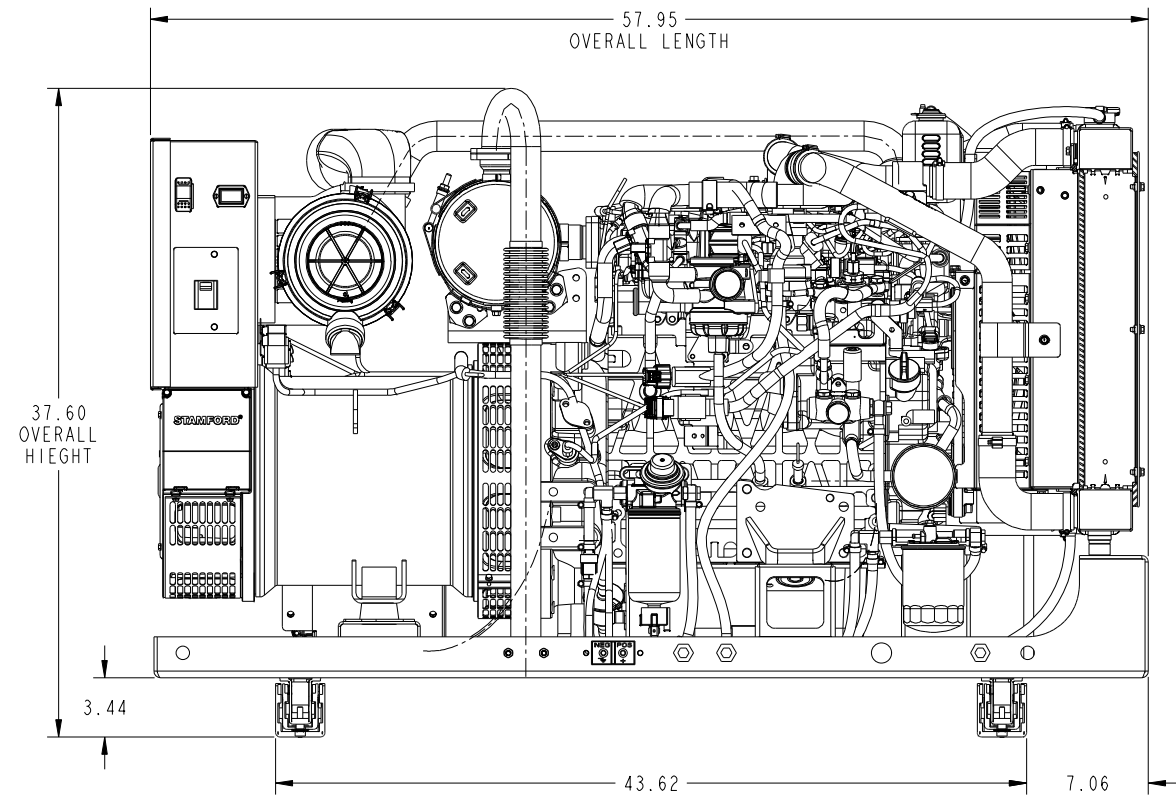

2X LOCKING LEVERS:
LOCKS AT THE FULLY CLOSED &
FULLY EXTENDED POSITIONS

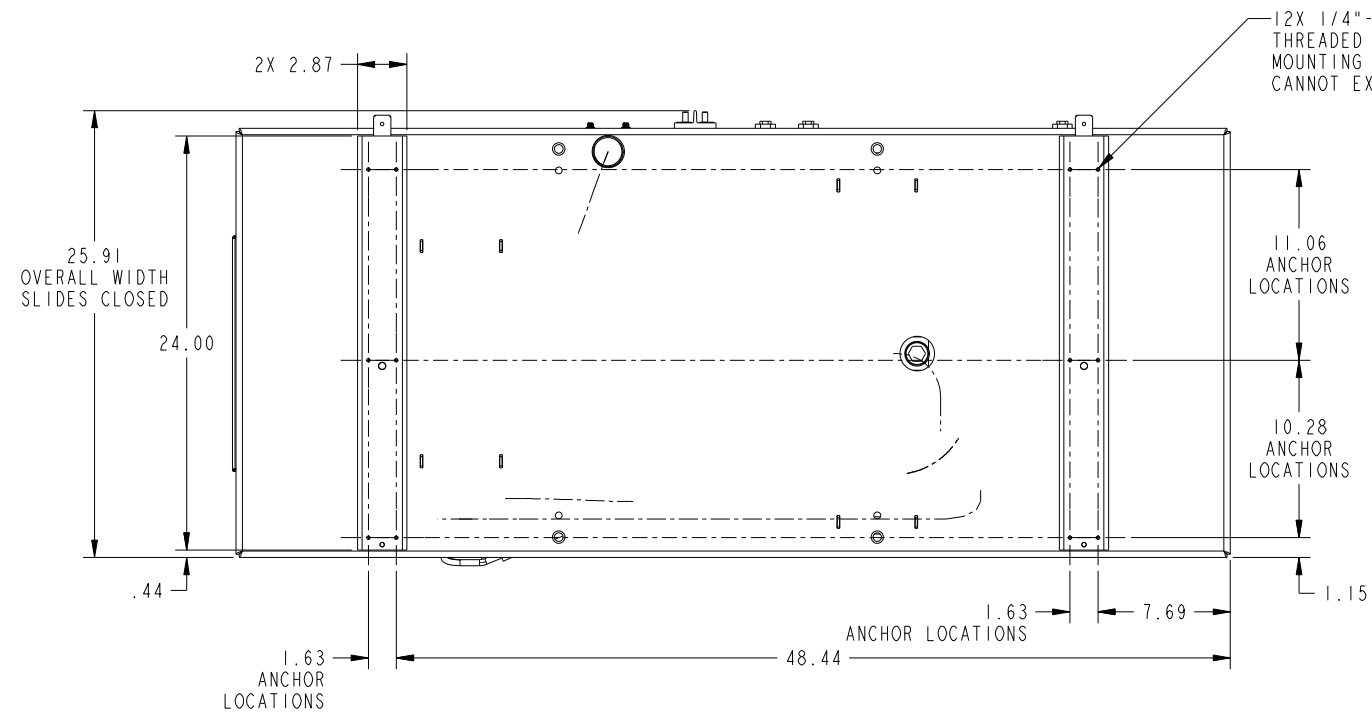
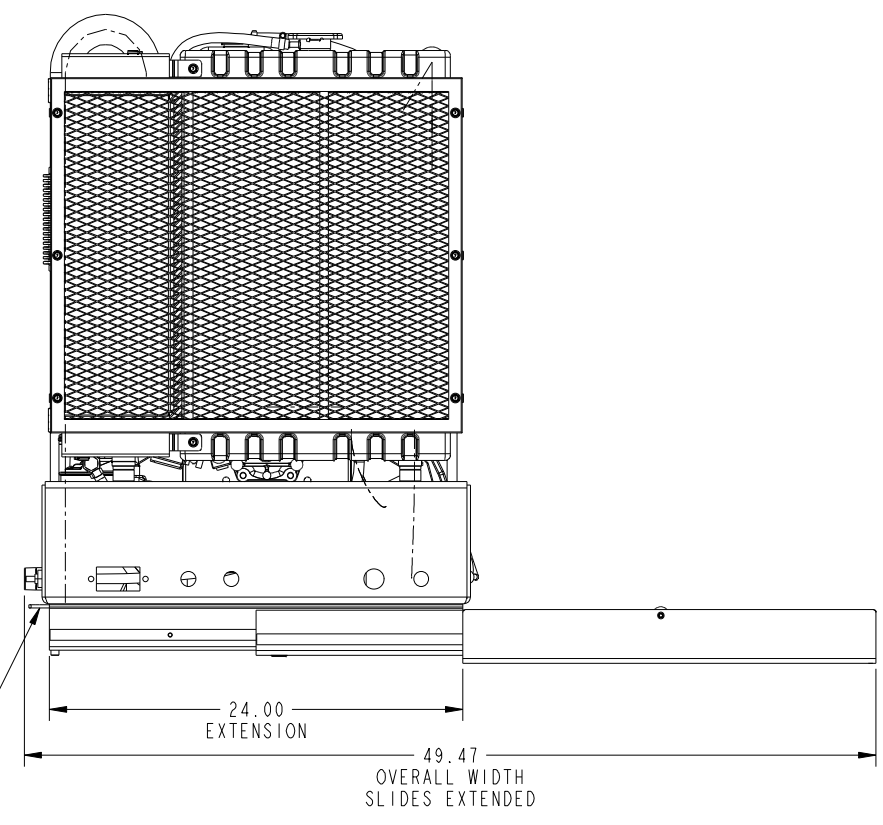

NOTES:
1. ALL DIMENSIONS ARE APPROXIMATE

DIMENSIONS ARE IN: INCHES [] ARE IN: MILLIMETERS DRAWING TOLERANCES UNLESS OTHERWISE SPECIFIED: X: ± .1 IN OR 4 mm X.L: ± .1 IN OR 4.2 mm X.H: ± .01 IN OR 0.25 mm X.XX: ± .01 IN OR 0.15 mm ANGULAR TOLERANCES: ± 1°	DO NOT SCALE PRINT SCALE: .188 	CMI DATA CLASSIFICATION Cummins Confidential DWN: NO134 CKD: - APVD: LG956 DATE: 23AUG2018	Cummins Inc. ITEM NAME GENERAL ASSEMBLY, GENSET OPEN-SET, W/ SLIDES, CM20-25 ITEM NUMBER CM20_25-01 CAD SHEET 2 OF 2
	FOR INTERPRETATION OF DIMENSIONING AND TOLERANCING, SEE ASME Y14.5-2009	MUST CONFORM TO CES 10903	

REV	REL NO	REVISION	DWN	CKD	APVD	DATE
-	2018-467	RELEASED TO PRODUCTION	NO134	-	LG956	23AUG18
A	2019-208	UPDATED PER A060R071; 49.64 WAS 49.69, 27.29 WAS 27.38, 1.64 WAS 1.69	OY256	NO134	LG956	26APR19

UNIT	NEWAGE GENERATOR FRAME SIZE	TOTAL WEIGHT OF UNIT
CM20-1	P1144H	1450 lbs
CM20-2		
CM20-3		
CM25-1		
CM25-2		
CM25-3		

FUEL SUPPLY	1/4" FNPT
FUEL RETURN	1/4" FNPT
COOLANT DRAIN	1/4" FNPT
POSITIVE BATTERY CONNECTION	5/16"-18 UNC
NEGATIVE BATTERY CONNECTION	5/16"-18 UNC
EXHAUST 90° OUTLET (SHIPPED LOOSE)	Ø 1.75"OD
ENGINE OIL CAPACITY	10 QUARTS
TOTAL COOLANT CAPACITY	5 GALLON

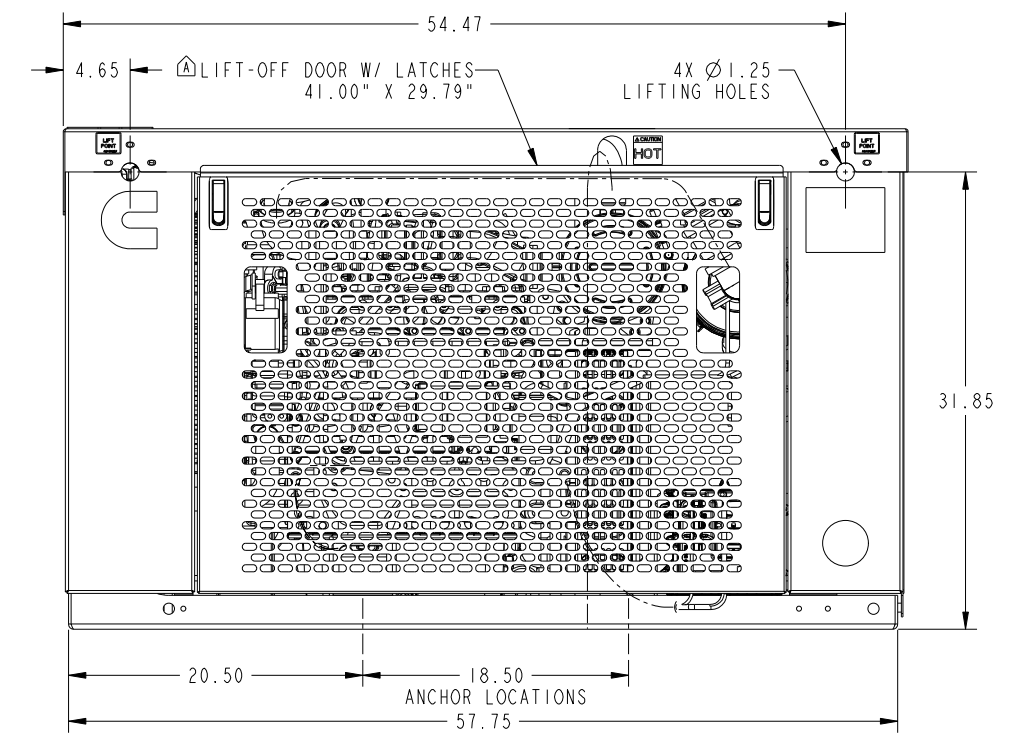
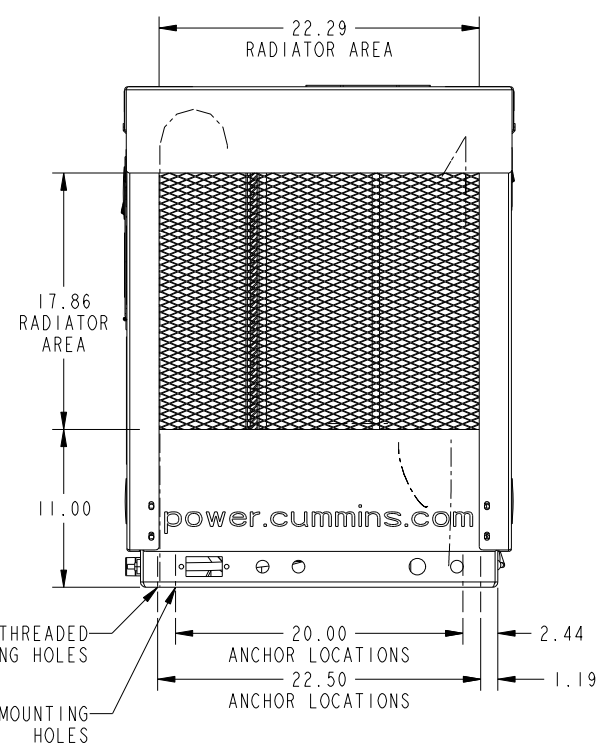
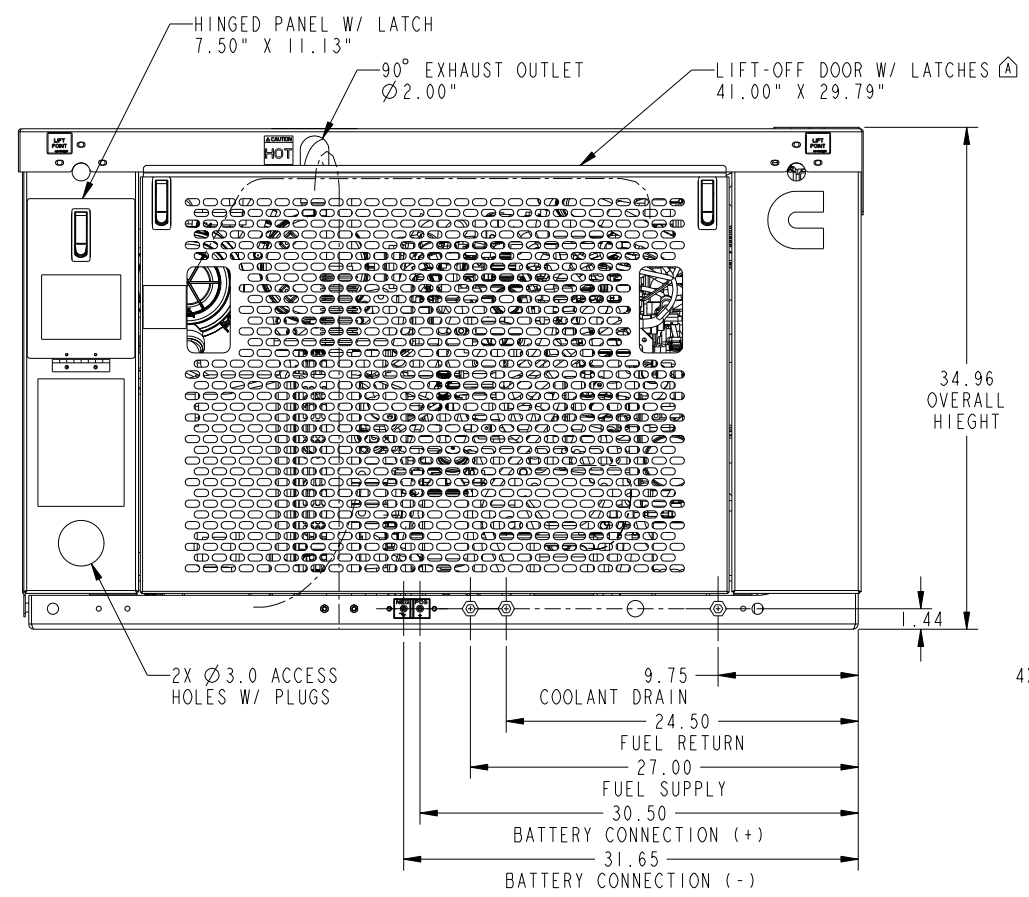
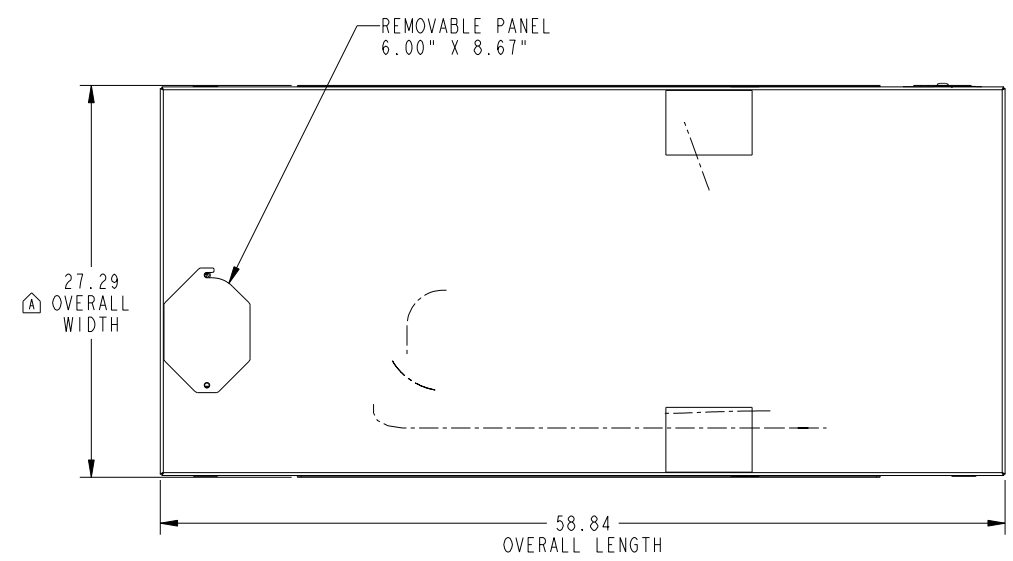
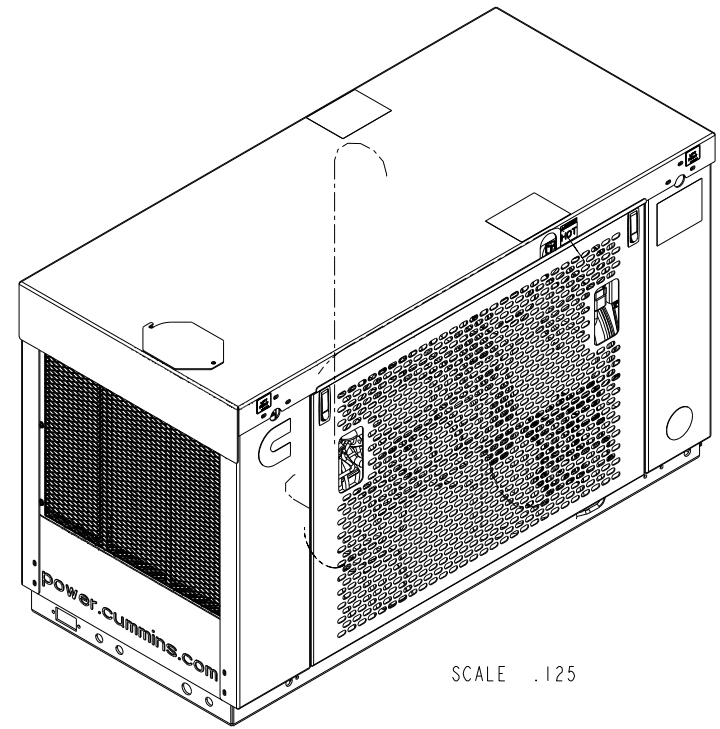

NOTES:
 1. ALL WEIGHTS & DIMENSIONS ARE APPROXIMATE
 2. SEE SHEET 2 FOR CM20-25 CLOSED-SET UNIT W/ SLIDES

DIMENSIONS ARE IN: INCHES [] ARE IN: MILLIMETERS	DO NOT SCALE PRINT	CMI DATA CLASSIFICATION Cummins Confidential		Cummins Inc.	
DRAWING TOLERANCES UNLESS OTHERWISE SPECIFIED: X: ± .1 IN OR 4 mm Y: ± .1 IN OR 4 mm Z: ± .001 IN OR 0.25 mm X: ± .010 IN OR 0.25 mm ANGULAR TOLERANCES: ±	SCALE: .156	DWN: NO134		ITEM NAME GENERAL ASSEMBLY, GENSET CLOSED-SET, W/ SLIDES, CM20-25	ITEM NUMBER CM20_25-02
THIS DOCUMENT AND THE INFORMATION SHOWN THEREON IS CONFIDENTIAL AND PROPRIETARY AND SHALL NOT BE DISCLOSED TO OTHERS IN HARD COPY OR ELECTRONIC FORM, REPRODUCED BY ANY MEANS, OR USED FOR ANY PURPOSE WITHOUT WRITTEN CONSENT OF CUMMINS INC.			FOR INTERPRETATION OF DIMENSIONING AND TOLERANCING, SEE ASME Y14.5-2009	MUST CONFORM TO CES 10903	

REV	REL NO	REVISION	DWN	CKD	APVD	DATE
-	2018-467	RELEASED TO PRODUCTION	NO134	-	LG956	23AUG18
A	2019-208	UPDATED PER A060R071; 49.64 WAS 49.69, 27.29 WAS 27.38, 1.64 WAS 1.69	OY256	NO134	LG956	26APR19

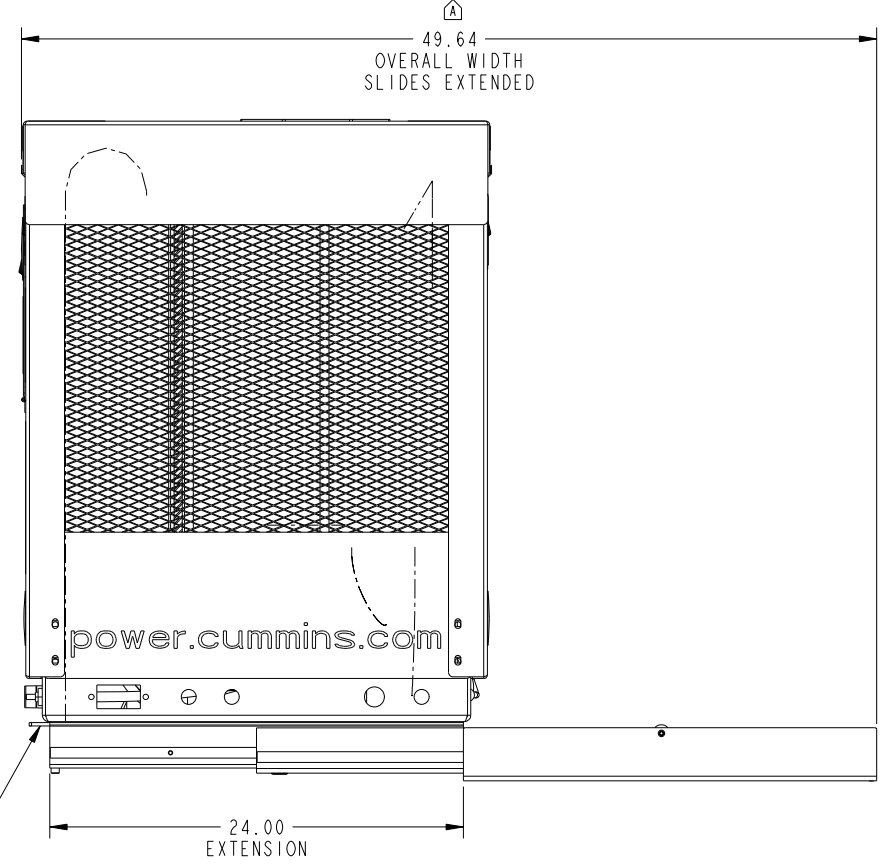
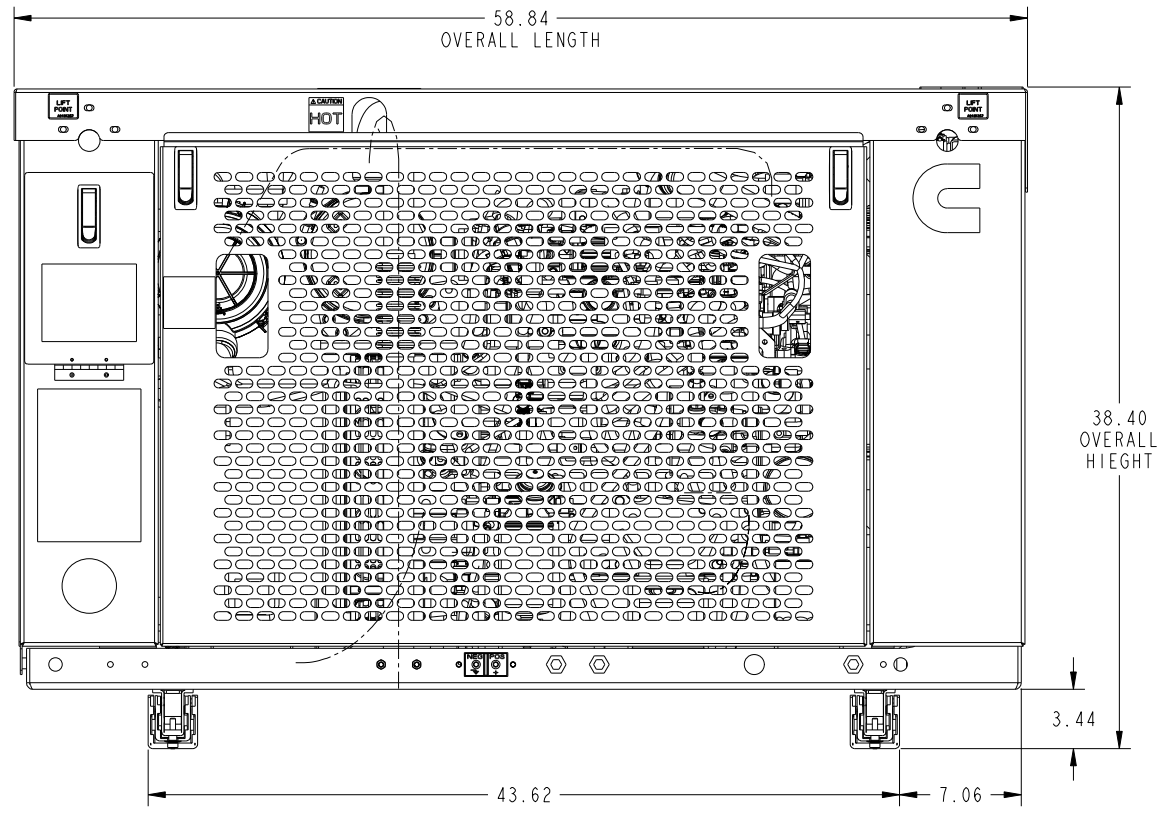

2X LOCKING LEVERS:
LOCKS AT THE FULLY CLOSED &
FULLY EXTENDED POSITIONS

12X 1/4"-20 UNC-2B
THREADED MOUNTING HOLES:
MOUNTING HARDWARE PENETRATION
CANNOT EXCEED 0.42"

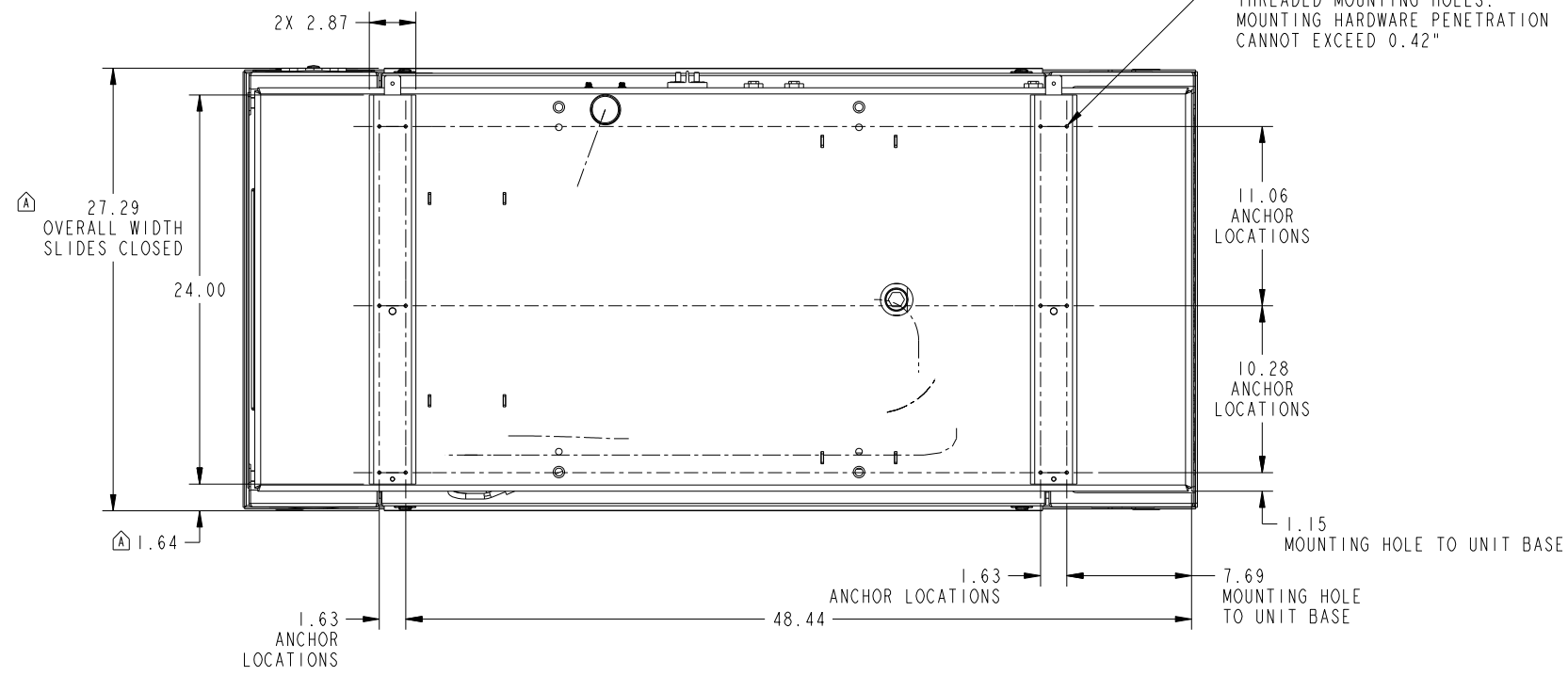

NOTES:
1. ALL DIMENSIONS ARE APPROXIMATE

DIMENSIONS ARE IN: INCHES [] ARE IN: MILLIMETERS DRAWING TOLERANCES UNLESS OTHERWISE SPECIFIED: X: ± 1/16 IN OR 1.6 mm Y: ± 1/32 IN OR 0.75 mm Z: ± 0.01 IN OR 0.25 mm ANGULAR TOLERANCES: ± 1°	DO NOT SCALE PRINT SCALE: .188 	CMI DATA CLASSIFICATION Cummins Confidential			Cummins Inc. ITEM NAME GENERAL ASSEMBLY, GENSET CLOSED-SET, W/ SLIDES, CM20-25	
		DWN: NO134 CKD: - APVD: LG956 DATE: 23AUG2018	MUST CONFORM TO CES 10903		ITEM NUMBER CM20-25-02	CAD SHEET 2 OF 2

REV	REL NO	REVISION	DWN	CKD	APVD	DATE
-	2017-166	RELEASED TO PRODUCTION	DP610	HV937	HV937	02FEB17
I	2019-003	ADDED REMOTE HMI CONNECTION. ADDED SHEET 2 FOR CUSTOMER CONNECTION VIEWS.	HV937	HV937	HV937	04JAN19
J	2019-201	REMOVED L2 AND ADDED L3 ON SINGLE PHASE 12 LEAD GEN.	DZ710	HV937	HV937	24APR19

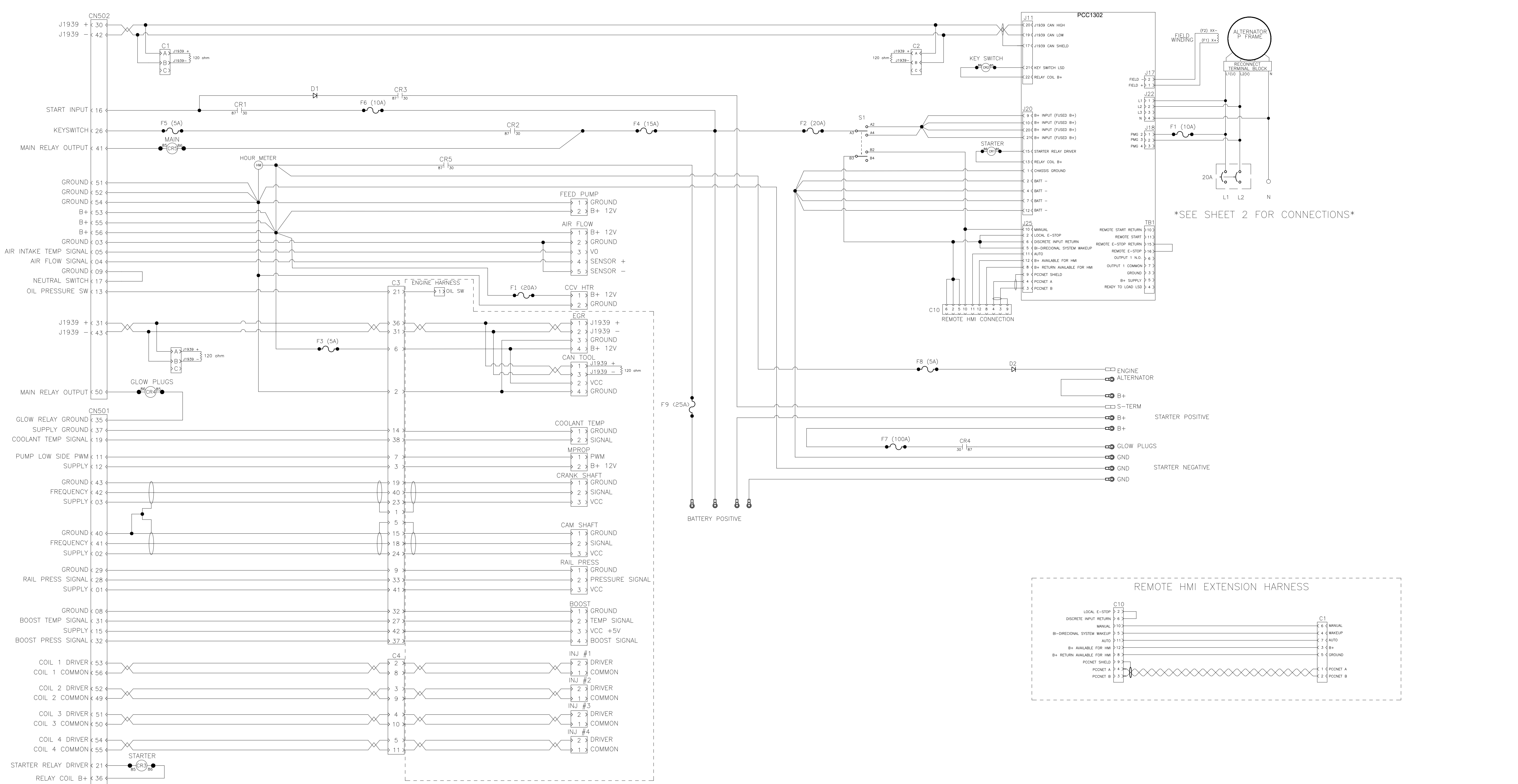

SEE SHEET 2 FOR CONNECTIONS



DIMENSIONS ARE IN: INCHES () ARE IN: MILLIMETERS DIMENSION TOLERANCES XX: ±0.0000 OR 2.5mm XXX: ±0.0000 OR 0.76mm XXXX: ±0.0150 OR 0.381mm ANGULAR TOLERANCES: 1°	DO NOT SCALE PRINT SCALE 1.00	OEM DATA CLASSIFICATION Cummins Confidential	ITEM NAME SCHEMATIC, OVERALL COMMERCIAL MOBILE 20/25KW
THIS DOCUMENT AND THE INFORMATION SHOWN THEREIN IS CONFIDENTIAL AND PROPRIETARY TO CUMMINS INC. IT IS TO BE USED FOR THE PURPOSE AND IN ACCORDANCE WITH THE TERMS AND CONDITIONS OF THE APPLICABLE CUMMINS INC. SUPPLY AGREEMENT.	FOR INTERPRETATION OF DIMENSIONS AND TOLERANCES, SEE ASME Y14.5-2009.	MUST CONFORM TO CES 10993	Cummins Inc. ITEM NUMBER A042F537 ACAD SHEET 1 OF 2

REV	REL NO	REVISION	DWN	CKD	APVD	DATE
-	2017-166	RELEASED TO PRODUCTION	DP610	HV937	HV937	02FEB17
I	2019-003	SEE SHEET 1 FOR LATEST REVISION	HV937	HV937	HV937	04JAN19
J	2019-201	SEE SHEET 1 FOR LATEST REVISION	DZ710	HV937	HV937	24APR19

12 LEAD GENERATOR

4 LEAD GENERATOR

3 PHASE

1 PHASE

1 PHASE

240 VOLTS L-L
120 VOLTS L-N

208 VOLTS L-L
120 VOLTS L-N

480 VOLTS L-L
277 VOLTS L-N

240 VOLTS L-L
120 VOLTS L-N

240 VOLTS L-L
120 VOLTS L-N

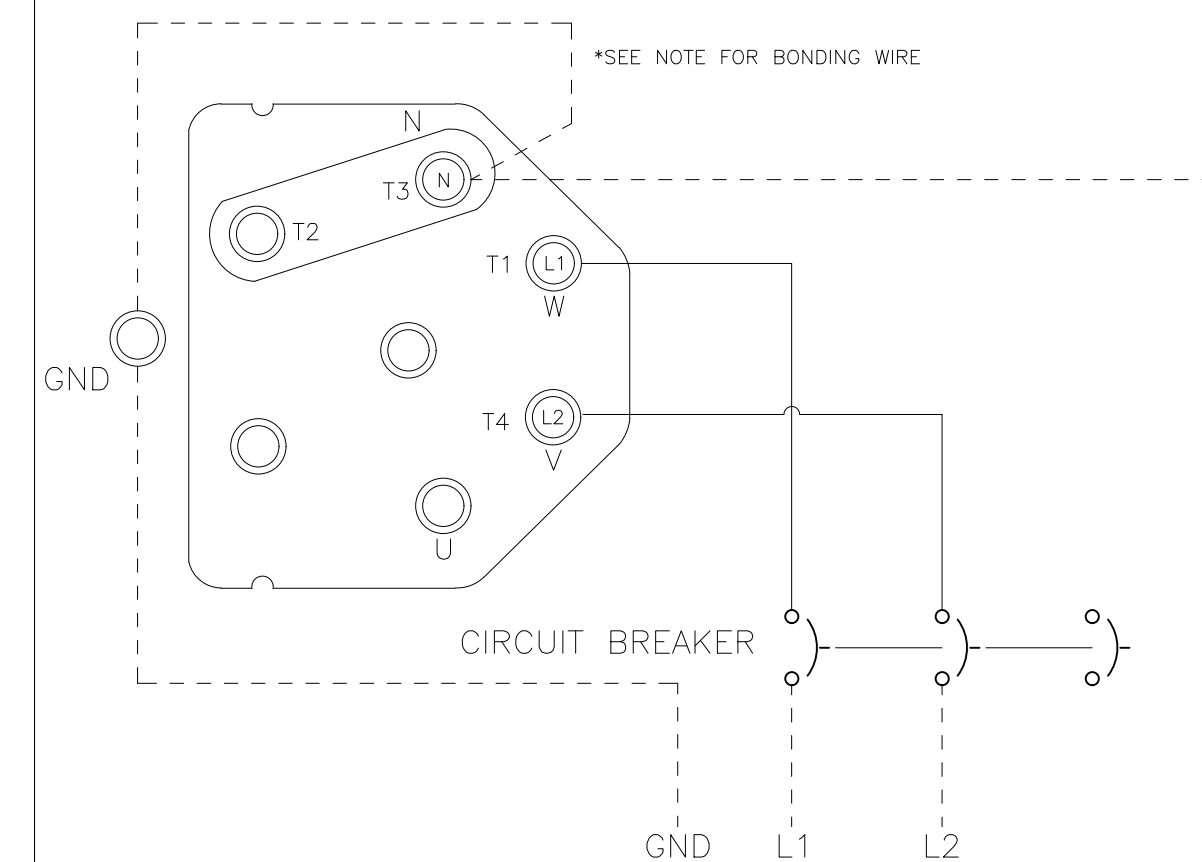
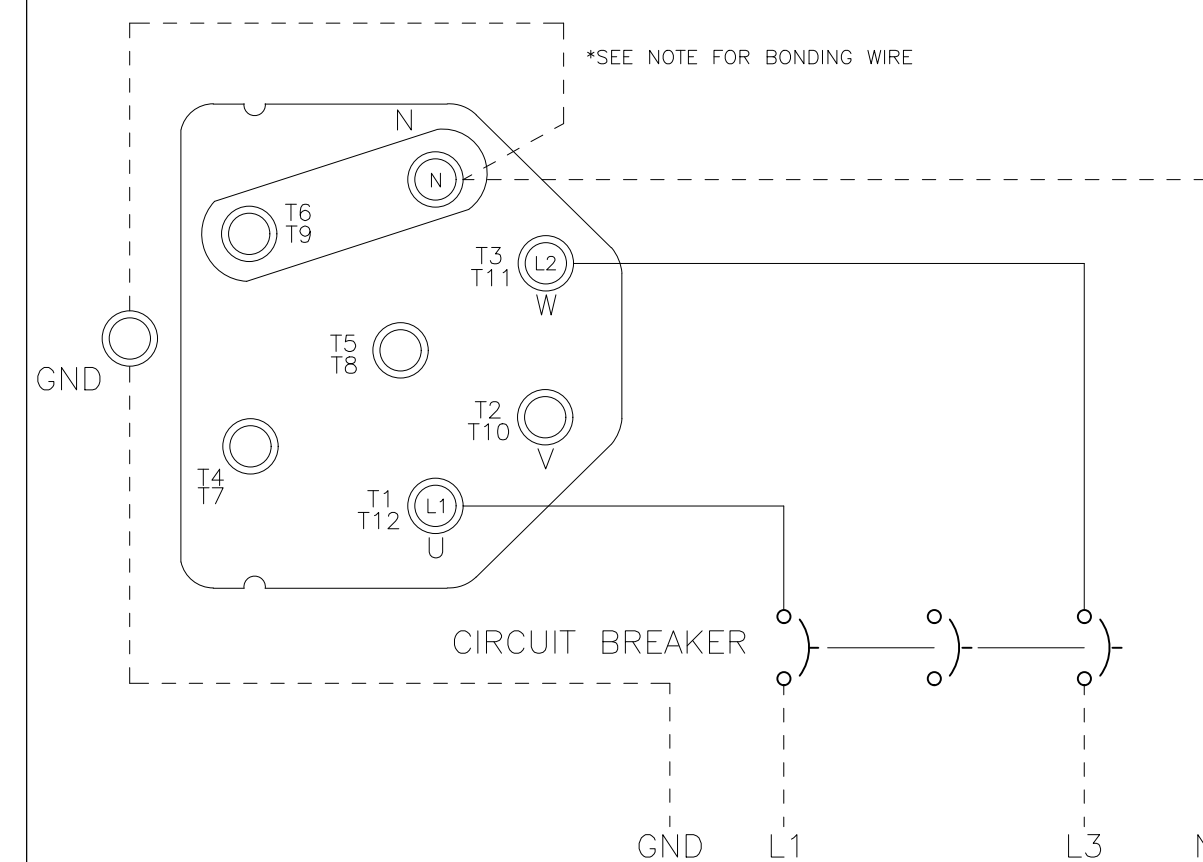
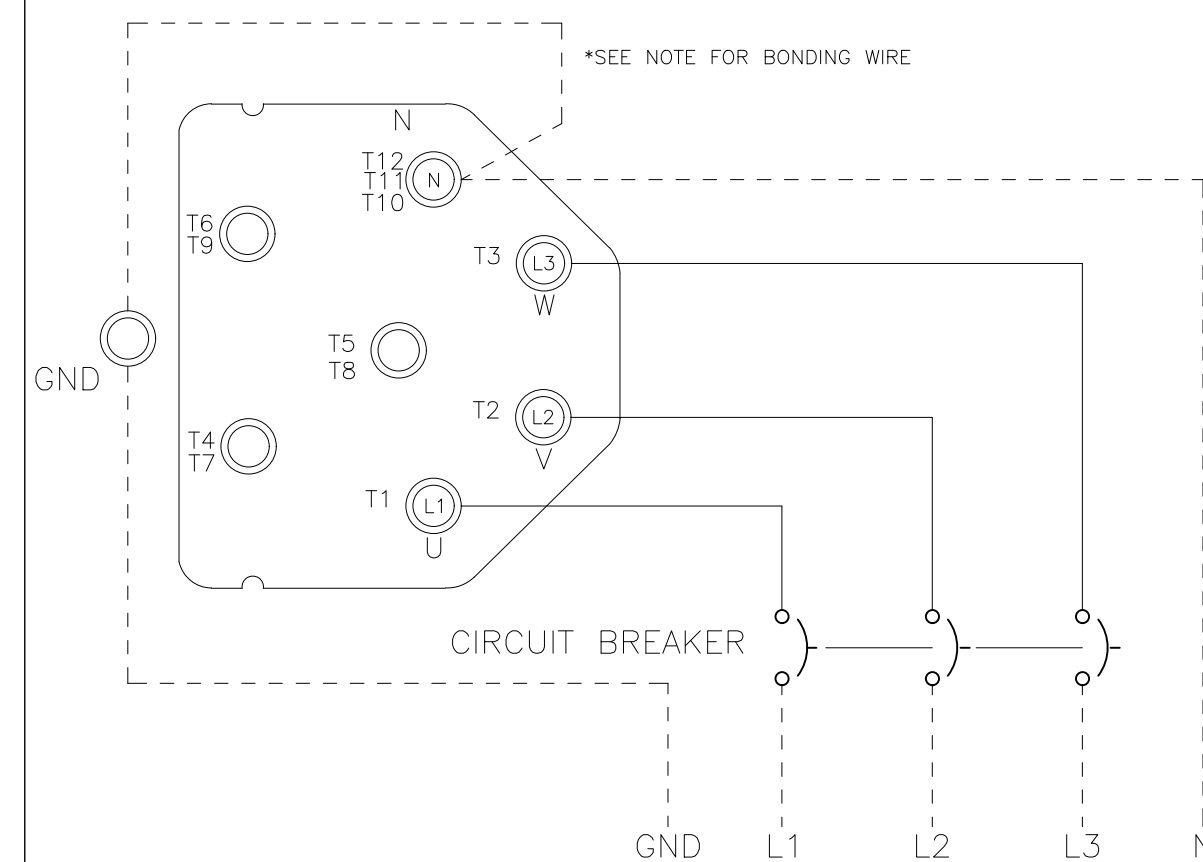
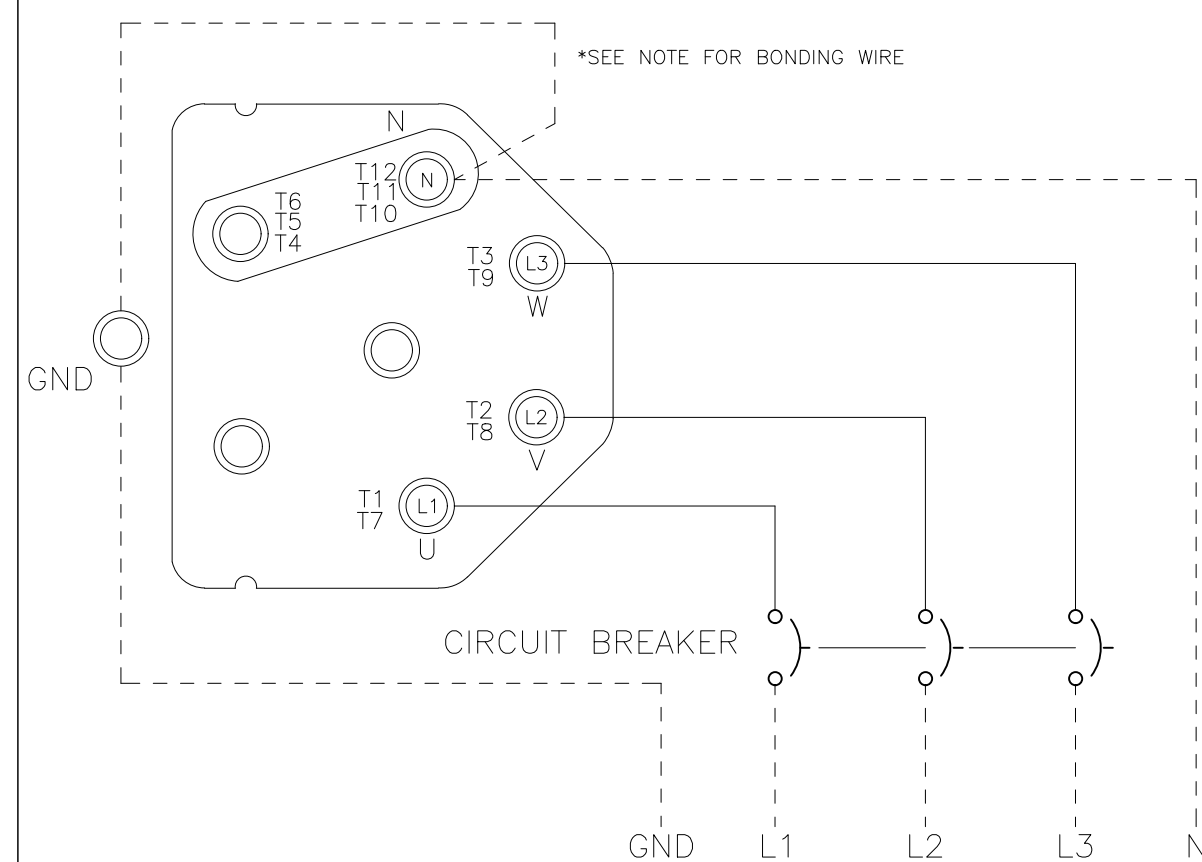
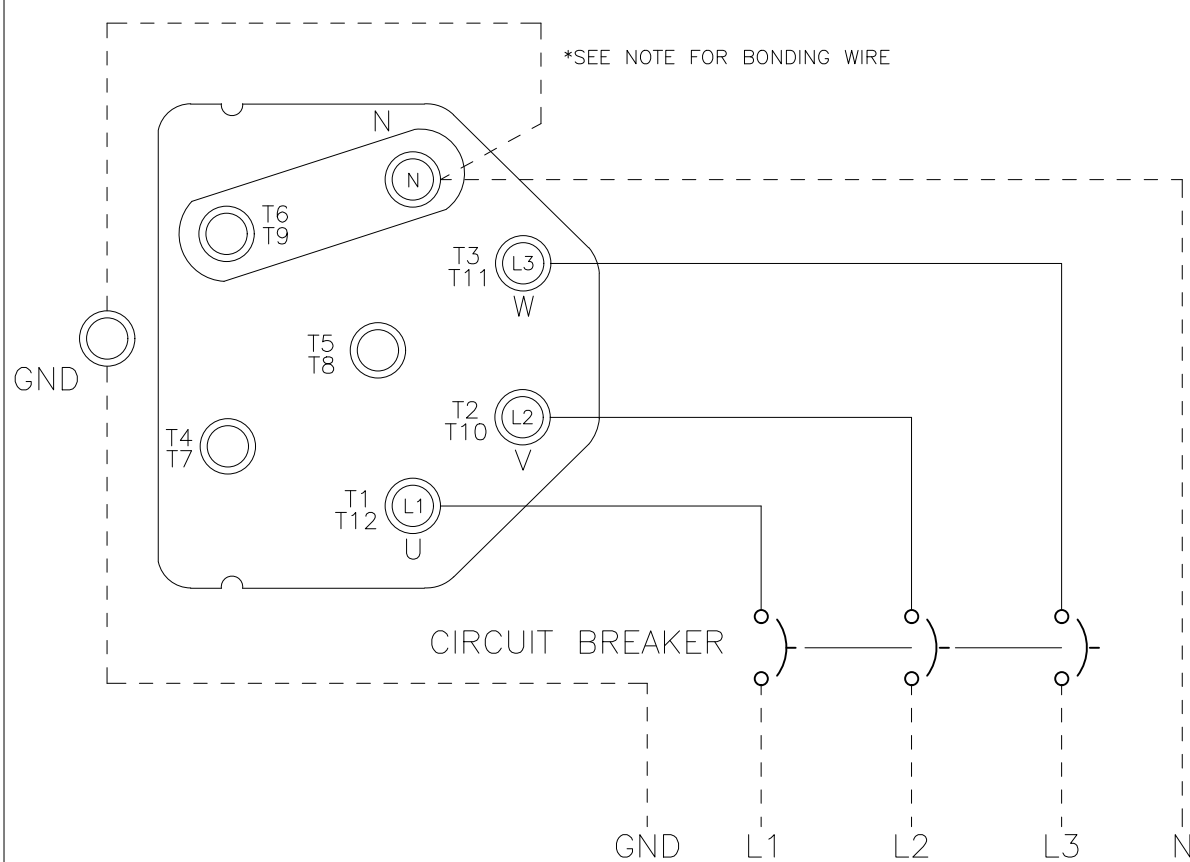
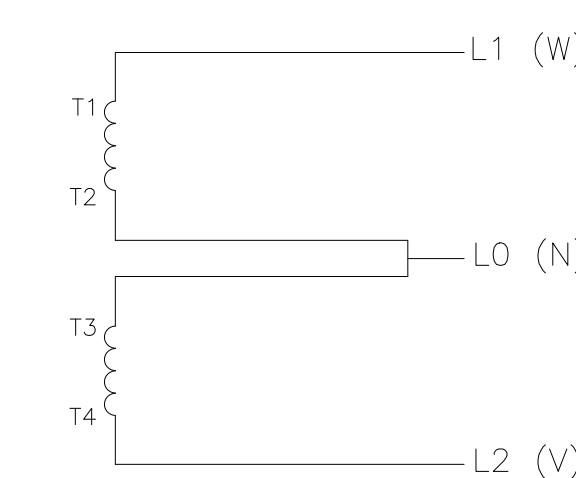
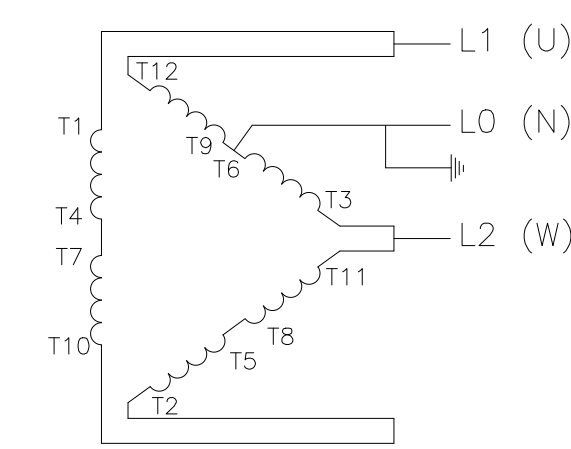
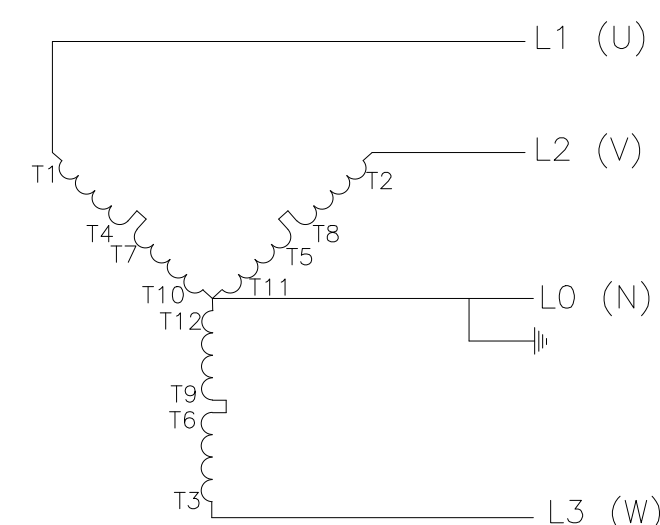
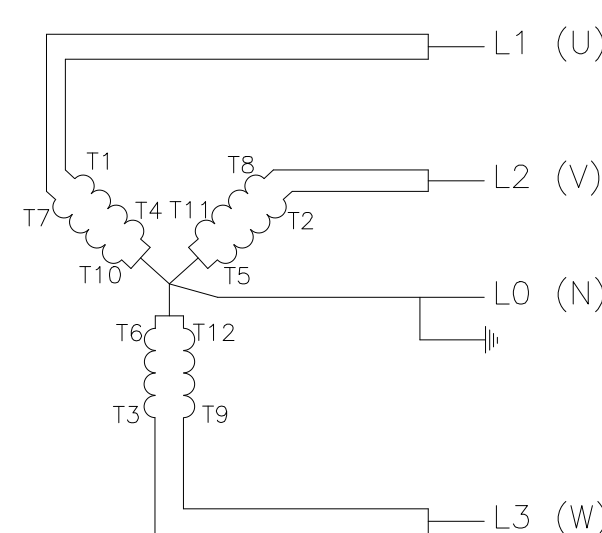
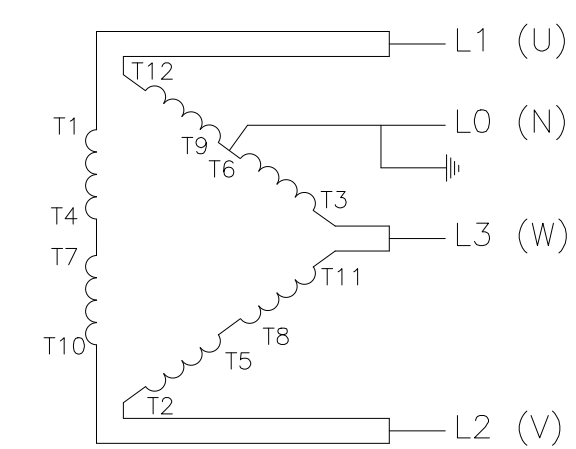

DASHED LINES = CUSTOMER CONNECTIONS

DASHED LINES = CUSTOMER CONNECTIONS

DASHED LINES = CUSTOMER CONNECTIONS

DASHED LINES = CUSTOMER CONNECTIONS

DASHED LINES = CUSTOMER CONNECTIONS

NOTES: 1) BOND THE NEUTRAL WIRE IN ACCORDANCE WITH THE NEC.

DIMENSIONS ARE IN: INCHES	DO NOT SCALE PRINT	CMV DATA CLASSIFICATION Cummins Confidential		Cummins Inc. ITEM NAME SCHEMATIC, OVERALL COMMERCIAL MOBILE 20/25KW
1 1/8 IN.	SCALE 1.00	DWN: OP610 CKD: HV937 APVD: HV937 DATE: 02 FEB 2017		
DIMENSION TOLERANCES XX: ±0.000 IN OR 2.5mm XXX: ±0.000 IN OR 0.76mm XXXX: ±0.015 IN OR 0.381mm ANGULAR TOLERANCE: 1°		FOR INTERPRETATION OF DIMENSIONS AND TOLERANCING, SEE ASME Y14.5-2009		MUST CONFORM TO CES 10903