

Operator's Manual

Mobile Generator

G25 (T4i)

G25 (T4f)



Type	G25 (T4i), G25 (T4f)
Document	5200015081 / 3300029587
Date	0221
Revision	14
Language	EN



Copyright notice

© Copyright 2021 by Wacker Neuson America Corporation

All rights, including copying and distribution rights, are reserved.

This publication may be photocopied by the original purchaser of the machine. Any other type of reproduction is prohibited without express written permission from Wacker Neuson America Corporation.

Any type of reproduction or distribution not authorized by Wacker Neuson America Corporation represents an infringement of valid copyrights. Violators will be prosecuted.

Trademarks

All trademarks referenced in this manual are the property of their respective owners.

Manufacturer

Wacker Neuson America Corporation

N92W15000 Anthony Avenue

Menomonee Falls, WI 53051 U.S.A.

Tel: (262) 255-0500 · Fax: (262) 255-0550 · Tel: (800) 770-0957

www.wackerneuson.com

Original instructions

This Operator's Manual presents the original instructions. The original language of this Operator's Manual is American English.

CALIFORNIA Proposition 65 Warning



WARNING

The engine exhaust from this product contains chemicals known to the State of California to cause cancer, birth defects, or other reproductive harm.



WARNING

Diesel engine exhaust and some of its constituents are known to the State of California to cause cancer, birth defects, and other reproductive harm.



WARNING

Cancer and Reproductive Harm -
www.P65Warnings.ca.gov.



WARNING

Batteries, battery posts, terminals and related accessories contain lead and lead compounds, and other chemicals known to the State of California to cause cancer and birth defects or other reproductive harm. WASH HANDS AFTER HANDLING.

This page is intentionally left blank.

Machine Identification

SAVE THESE INSTRUCTIONS—This manual contains important instructions for the machine models below. These instructions have been written expressly by Wacker Neuson Production Americas LLC and must be followed during installation, operation, and maintenance of the machines.

Machine	Item Number
G 25	5000620640, 5000620641, 5000620642, 5000620709, 5000620931, 5200001316, 5200003991, 5200005557, 5200009370, 5200009371, 5200009372, 5200009373, 5200009374, 5200009375, 5200009376, 5200009377, 5200014460, 5200014461, 5200014462, 5200022587, 5100014166, 5100014167, 5100017591, 5100025836, 5100041580, 5100041581, 5100041582, 5100041583, 5100041584, 5100041592, 5100042507, 5100042508, 5100042509, 5100042510, 5100042512

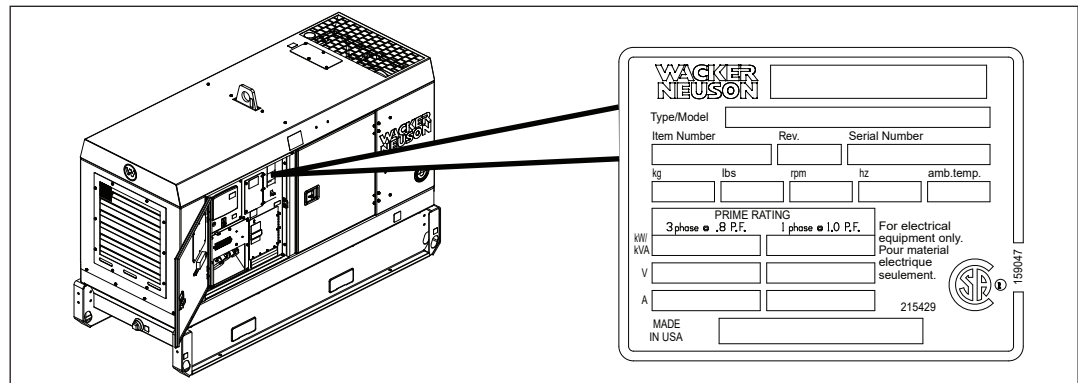

wc_gr013037

Machine identification

A nameplate listing the model number, item number, revision number, and serial number is attached to this machine. The location of the nameplate is shown above.

Serial number (S/N)

For future reference, record the serial number in the space provided below. You will need the serial number when requesting parts or service for this machine.

Serial Number:

Foreword

Machine documentation

- From this point forward in this documentation, Wacker Neuson Production Americas LLC will be referred to as Wacker Neuson.
 - Keep a copy of the Operator's Manual with the machine at all times.
 - For spare parts information, please see your Wacker Neuson Dealer, or visit the Wacker Neuson website at <http://www.wackerneuson.com/>.
 - When ordering parts or requesting service information, be prepared to provide the machine model number, item number, revision number, and serial number.
-

Expectations for information in this manual

- This manual provides information and procedures to safely operate and maintain the above Wacker Neuson model(s). For your own safety and to reduce the risk of injury, carefully read, understand, and observe all instructions described in this manual.
 - Wacker Neuson expressly reserves the right to make technical modifications, even without notice, which improve the performance or safety standards of its machines.
 - The information contained in this manual is based on machines manufactured up until the time of publication. Wacker Neuson reserves the right to change any portion of this information without notice.
 - The illustrations, parts, and procedures in this manual refer to Wacker Neuson factory-installed components. Your machine may vary depending on the requirements of your specific region.
-

CALIFORNIA Proposition 65 Warning

Combustion exhaust, some of its constituents, and certain vehicle components contain or emit chemicals known to the State of California to cause cancer and birth defects or other reproductive harm.

Laws pertaining to spark arresters

NOTICE: State Health Safety Codes and Public Resources Codes specify that in certain locations spark arresters be used on internal combustion engines that use hydrocarbon fuels. A spark arrester is a device designed to prevent accidental discharge of sparks or flames from the engine exhaust. Spark arresters are qualified and rated by the United States Forest Service for this purpose. In order to comply with local laws regarding spark arresters, consult the engine distributor or the local Health and Safety Administrator.

Manufacturer's approval

This manual contains references to *approved* parts, attachments, and modifications. The following definitions apply:

- **Approved parts or attachments** are those either manufactured or provided by Wacker Neuson.
- **Approved modifications** are those performed by an authorized Wacker Neuson service center according to written instructions published by Wacker Neuson.
- **Unapproved parts, attachments, and modifications** are those that do not meet the approved criteria.

Unapproved parts, attachments, or modifications may have the following consequences:

- Serious injury hazards to the operator and persons in the work area
- Permanent damage to the machine which will not be covered under warranty

Contact your Wacker Neuson dealer immediately if you have questions about approved or unapproved parts, attachments, or modifications.

Abbreviations

Abbreviation or Acronym	Definition	Abbreviation or Acronym	Definition
ATS	Automatic transfer switch	L3	Level load logic
CARB	California Air Resource Board	LT	Light truck
CDL	Commercial driver's license	MAF	Mass air flow
CKP	Crank position	NC	Normally closed
CMP	Camshaft position	NHTSA	National Highway Traffic Safety Administration
CO	Carbon monoxide	NOx	Nitrogen oxides
DEF	Diesel exhaust fluid	P/L	Pressure limiter
DM	Dosing module	PPE	Personal protective equipment
DOC	Diesel oxidation catalyst	S/N	Serial number
DTC	Diagnostic trouble codes	SCR	Selective catalytic reduction
EGR	Exhaust gas recirculation	SPN	Suspect parameter number
EPA	Environmental Protection Agency	ST	Special trailer
ERT	Extended run tank	TDG	Canadian Transportation of Dangerous Goods Act
FMI	Failure mode identifier	TWI	Treadwear indicators
GAWR	Gross axle weight ratings	VCW	Vehicle capacity weight
IBC	Intermediate bulk container	—	—

This page is intentionally left blank.

	CALIFORNIA Proposition 65 Warning	3
	Machine Identification	5
	Foreword	6
1	Safety Information	16
1.1	Signal Words Used in this Manual	16
1.2	Machine Description and Intended Use	17
1.3	Safety Guidelines for Operating the Machine	18
1.4	Service Safety	19
1.5	Operator Safety while Using Internal Combustion Engines	21
1.6	Safety Guidelines for Mobile Generators	22
1.7	Safety Guidelines for Towing the Machine	23
1.8	Safety Guidelines for Lifting the Machine	24
1.9	Reporting Safety Defects	24
2	Label Locations	25
3	Label Meanings	27
4	Lifting and Transporting	37
4.1	Lifting the Machine	37
4.2	Before Towing Checklist	38
4.3	Towing the Machine	39
4.4	Preparing the Machine for Transport on a Truck or Trailer	40
4.5	Hazardous Materials Placards	41
4.6	Testing the Breakaway System—Hydraulic Surge Brakes	42
4.7	Testing the Breakaway System—Electric Brakes	43
5	Machine Setup	45
5.1	Preparing the Machine for First Use	45
5.2	Positioning the Machine	46
5.3	Grounding the Generator	47
5.4	Recommended Fuel	48
5.5	Refueling the Machine—Basler Controller	49
5.6	Refueling the Machine—Deep Sea Controller	50

6	Operation, Control, and Component Locations	51
6.1	Control and Component Locations	51
7	Operation—Basler Controller	53
7.1	Main Circuit Breaker	53
7.2	Engine Start Switch	54
7.3	Generator Pre-Alarms and Alarms (Shut-Down Conditions)	55
7.4	Overcurrent Condition	56
7.5	Function of the Crankcase Pressure Switch (if equipped)	57
7.6	Using the Lugs and the Convenience Receptacles	59
7.7	Selecting the Voltage	61
7.8	Wet Stacking	63
7.9	Before Starting the Machine	64
7.10	Starting and Running the Machine	65
7.11	Stopping the Machine	67
7.12	Emergency Stop Switch	67
7.13	LCD Panel: Monitoring Machine Operation	68
8	Working with Basler Controller	70
8.1	How to Use the Generator Controller LCD and Keypad	70
8.2	Menu Diagram of the Generator Controller	71
8.3	Menu Diagram Components	72
8.4	Using the Metering and Settings Menus	73
8.5	Logging in to the Generator Controller by Entering the Password	74
8.6	Adjusting the LCD Screen Contrast	77
8.7	Changing the Time/Date Settings	78
8.8	Changing the Sender Fail Time Delays	79
8.9	Changing the Units of Measure	81
8.10	Changing the Low Fuel Pre-Alarm Setting	82
8.11	Changing or Disabling the Low Fuel Alarm Setting	83
8.12	Changing the Cooldown Time Setting	85
8.13	Changing the Pre-Crank Time Delay (Glow Plug Timer)	86
8.14	Changing the Maintenance Interval	88
8.15	Resetting the Maintenance Interval Pre-Alarm	90
8.16	Resetting a Loss of Voltage Pre-Alarm	91
8.17	Accessing and Using the Event Log	92

9	Operation—Deep Sea Controller	94
9.1	Main Circuit Breaker	94
9.2	Generator Controller Power Switch	95
9.3	Function of the Crankcase Pressure Switch (if equipped)	96
9.4	Selecting the Voltage	98
9.5	Wet Stacking	100
9.6	Deep Sea Controller Buttons/Functions	101
9.7	Generator Controller Alarms and Shut-Down Conditions	103
9.8	Before Starting the Machine	105
9.9	Starting and Running the Generator	106
9.10	Stopping the Generator	108
9.11	Emergency Stop Switch	109
9.12	Engine and Generator Monitoring	110
10	Working with Deep Sea Controller: DSE 7310 MKII	111
10.1	Introduction	111
10.2	Navigating the Menus	112
10.3	Adjusting Screen Contrast	114
10.4	How to Reset the Maintenance Timer	115
11	How to Connect Loads—480V	116
11.1	Lug Terminal Connection Diagrams	116
11.2	Best Practices for Balancing Loads	117
11.3	Connecting 480V, 3-Phase and Single-Phase Loads	120
11.4	Connecting a 240V 3Ø Load and a 240V 1Ø Load	121
11.5	Connecting 240V and 120V Single-Phase Loads	122
11.6	Connecting a 208V 3Ø Load and Multiple 120V 1Ø Loads	123
11.7	Connecting a 220–240V 3Ø Load and Multiple 127–133V 1Ø Loads	124
12	How to Connect Loads—600V	125
12.1	Lug Terminal Connection Diagrams	125
12.2	Best Practices for Balancing Loads	126
12.3	Connecting a 240V 3Ø Load and a 240V 1Ø Load	129
12.4	Connecting 240V and 120V Single-Phase Loads	130
12.5	Connecting a 208V 3Ø Load and Multiple 120V 1Ø Loads	131
12.6	Connecting a 220–240V 3Ø Load and Multiple 127–133V 1Ø Loads	132
12.7	Connecting 480V, 3-Phase Loads	133
12.8	Connecting 600V, 3-Phase Loads	134

13	Using Remote Start Capabilities	135
13.1	Remote Run Terminal Block	135
13.2	Remote Transfer Switch	136
13.3	Preparing for Automatic/Remote Start-Up—Deep Sea	137
14	Diagnostic Trouble Codes (DTC)	139
14.1	Accessing DTCs with the Basler Controller	139
14.2	Accessing Engine DTCs using the Deep Sea Controller	140
14.3	List of Engine Diagnostic Trouble Codes (DTCs)	141
15	Factory-Installed Options	154
15.1	Battery Charger	154
15.2	Lockable Battery Disconnect	155
15.3	Camlocks	156
15.4	Containment System	157
15.5	Extended Run Tank (ERT)	157
15.6	Engine Block Heater	158
15.7	Cold-Weather Thermostat	158
15.8	Low Coolant Shutdown	159
15.9	Temperature-Activated Shutters	160
15.10	Positive Air Shutoff Valve	161
15.11	Connecting an External Fuel Supply	162
15.12	Lube Level Maintainer	163
16	General Maintenance	164
16.1	Periodic Maintenance Schedule	164
16.2	Maintaining the Emission Control System	165
16.3	Preparing for Maintenance	165
16.4	Cleaning the Machine	165
16.5	Inspecting the Machine	166
16.6	Maintaining the Trailer	166
16.7	Checking and Draining the Containment System (if equipped)	167
16.8	Checking the Exhaust System	168
16.9	Maintaining the Battery	169
16.10	Cleaning the Diesel Particulate Filter (DPF) (if equipped)	170
16.11	Filling the Radiator	171

16.12	Replacing the Aftertreatment DEF Dosing Unit Filter (if equipped)	172
16.13	Storage	173
16.14	Machine Disposal and Decommissioning	174
17	Maintenance Tier 4i Engines: Isuzu	176
17.1	Coolant	179
18	Maintenance Tier 4f Engines: Isuzu	180
18.1	Coolant	184
19	Troubleshooting	185
20	Technical Data	186
20.1	Engine	186
20.2	Generator	188
20.3	Trailer and Skid	190
20.4	Dimensions	191
21	Tire Safety Information	192
22	User’s Information for Transport Canada Fuel Tank	204
23	Emission Control Systems Information and Warranty—Diesel	207
23.1	Emission Control System Background Information	207
23.2	Limited Defect Warranty for Exhaust Emission Control System	207
23.3	Limited Defect Warranty for Wacker Neuson Emission Control Systems	208
24	General Machine Schematics	211
24.1	Fuses	212
24.2	Trailer Wiring	212
24.3	Trailer Wiring Components	213

25	Schematics—Machines with Basler Controller	214
25.1	AC Schematic	214
25.2	AC Schematic Components	215
25.3	DC Schematic: G25, T4i Isuzu, Basler	216
25.4	DC Schematic Components: G25, T4i Isuzu, Basler	217
25.5	DC Schematic: G25, T4f Isuzu, Basler	218
25.6	DC Schematic Components: G25, T4f Isuzu, Basler	219
25.7	AC Schematic G25, Isuzu, 600V, Basler	220
25.8	AC Schematic Components G25, Isuzu, 600V, Basler	221
26	Schematics—Machines with Deep Sea Controller	222
26.1	AC Schematic: G25 480V	222
26.2	AC Schematic Components: G25 480V	223
26.3	AC Schematic: G25 600V	224
26.4	AC Schematic Components: G25 600V	225
26.5	AC Schematic: T4i, T4f	226
26.6	AC Schematic Components: T4i, T4f	227
26.7	DC Schematic: T4i, Deep Sea	228
26.8	DC Schematic Components: T4i, Deep Sea	229
26.9	DC Schematic: T4f	230
26.10	DC Schematic Components: T4f	231

1 Safety Information

1.1 Signal Words Used in this Manual

This manual contains DANGER, WARNING, CAUTION, *NOTICE*, and NOTE signal words which must be followed to reduce the possibility of personal injury, damage to the equipment, or improper service.



This is the safety alert symbol. It is used to alert you to potential personal hazards.

- ▶ Obey all safety messages that follow this symbol.



DANGER

DANGER indicates a hazardous situation which, if not avoided, will result in death or serious injury.

- ▶ To avoid death or serious injury from this type of hazard, obey all safety messages that follow this signal word.



WARNING

WARNING indicates a hazardous situation which, if not avoided, could result in death or serious injury.

- ▶ To avoid possible death or serious injury from this type of hazard, obey all safety messages that follow this signal word.



CAUTION

CAUTION indicates a hazardous situation which, if not avoided, could result in minor or moderate injury.

- ▶ To avoid possible minor or moderate injury from this type of hazard, obey all safety messages that follow this signal word.

NOTICE: Used without the safety alert symbol, NOTICE indicates a situation which, if not avoided, could result in property damage.

Note: A Note contains additional information important to a procedure.

1.2 Machine Description and Intended Use

Machine description This machine is a mobile electric power source. The Wacker Neuson Mobile Generator consists of a trailer-mounted cabinet containing an electric alternator, a fuel tank, and a diesel engine. A control panel, receptacles, and connection lugs are provided on the side of the cabinet. As the engine runs, the generator converts mechanical energy into electric power. The operator connects loads to the electric power receptacles and connection lugs.

Intended use This machine is intended for the purpose of supplying electrical power to connected loads. Refer to the product specifications for the output voltage and frequency of this generator, and for the maximum output power limit of this generator.

This machine has been designed and built strictly for the intended use described above. Using the machine for any other purpose could permanently damage the machine or seriously injure the operator or other persons in the area. Machine damage caused by misuse is not covered under warranty.

The following are some examples of misuse:

- Connecting a load that has voltage and frequency requirements that are incompatible with the generator output
 - Overloading the generator with a load that draws excessive power during either continuous running or start-up
 - Operating the generator in a manner that is inconsistent with all federal, state and local codes and regulations
 - Using the machine as a ladder, support, or work surface
 - Using the machine to carry or transport passengers or equipment
 - Using the machine to tow other machines
 - Operating the machine outside of factory specifications
 - Operating the machine in a manner inconsistent with all warnings found on the machine and in the Operator's Manual
-

This machine has been designed and built in accordance with the latest global safety standards. It has been carefully engineered to eliminate hazards as far as practicable and to increase operator safety through protective guards and labeling. However, some risks may remain even after protective measures have been taken. They are called residual risks. On this machine, they may include exposure to:

- Heat, noise, exhaust, and carbon monoxide from the engine
- Fire hazards from improper refueling techniques
- Fuel and its fumes
- Electric shock and arc flash
- Personal injury from improper lifting the trailer tongue
- Typical hazards related to towing a trailer on roads and highways

To protect yourself and others, make sure you thoroughly read and understand the safety information presented in this manual before operating the machine.

1.3 Safety Guidelines for Operating the Machine

Operator training

Before operating the machine:

- Read and understand the operating instructions contained in all manuals delivered with the machine.
- Familiarize yourself with the location and proper use of all controls and safety devices.
- Contact Wacker Neuson for additional training if necessary.

When operating this machine:

- Do not allow improperly trained people to operate the machine. People operating the machine must be familiar with the potential risks and hazards associated with it.
-

Operator qualifications

Only trained personnel are permitted to start, operate, and shut down the machine. They also must meet the following qualifications:

- Have received instruction on how to properly use the machine
- Are familiar with required safety devices

The machine must not be accessed or operated by:

- Children
 - People impaired by alcohol, drugs, or prescription drugs
-

Application area

Be aware of the application area.

- Keep unauthorized personnel, children, and pets away from the machine.
 - Remain aware of changing positions and the movement of other equipment and personnel in the application area/job site.
 - Identify whether special hazards exist in the application area, such as toxic gases or unstable ground conditions, and take appropriate action to eliminate the special hazards before using the machine.
 - Do not operate the machine in areas that contain flammable objects, fuels, or products that produce flammable vapors.
-

Safety devices, controls, and attachments

Only operate the machine when:

- All safety devices and guards are in place and in working order.
- All controls operate correctly.
- The machine is set up correctly according to the instructions in the Operator's Manual.
- The machine is clean.
- The machine's labels are legible.

To ensure safe operation of the machine:

- Do not operate the machine if any safety devices or guards are missing or inoperative.
- Do not modify or defeat the safety devices.
- Only use accessories or attachments that are approved by Wacker Neuson.

Safe operating practices

When operating this machine:

- Remain aware of the machine's moving parts. Keep hands, feet, and loose clothing away from the machine's moving parts.
 - Do not operate a machine in need of repair.
 - Do not consume the operating fluids used in this machine. Depending on your machine model, these operating fluids may include water, wetting agents, fuel (gasoline, diesel, kerosene, propane, or natural gas), oil, coolant, hydraulic oil, heat transfer fluid (propylene glycol with additives), battery acid, or grease.
-

Personal protective equipment (PPE)

Wear the following personal protective equipment (PPE) while operating this machine:

- Close-fitting work clothes that do not hinder movement
 - Safety glasses with side shields
 - Hearing protection
 - Safety-toed footwear
-

After use

- Stop the engine when the machine is not being operated.
- Close the fuel valve on engines equipped with one when the machine is not being operated.
- Ensure that the machine will not tip over, roll, slide, or fall when not being operated.
- Store the machine properly when it is not being used. The machine should be stored in a clean location out of the reach of children.

1.4 Service Safety

Service training

Before servicing or maintaining the machine:

- Read and understand the instructions contained in all manuals delivered with the machine.
- Familiarize yourself with the location and proper use of all controls and protective devices.
- Only trained personnel shall troubleshoot or repair problems occurring with the machine.
- Contact Wacker Neuson for additional training if necessary.

When servicing or maintaining this machine:

- Do not allow untrained or improperly trained people to service or maintain the machine. Personnel servicing or maintaining the machine must be familiar with the associated potential risks and hazards.
-

Precautions

When servicing or maintaining the machine:

- Read and understand the service procedures before performing any service to the machine.
- All adjustments and repairs must be completed before operating the machine. Do not operate the machine with a known problem or deficiency.
- All repairs and adjustments shall be completed by a qualified technician.
- Turn off the machine before performing maintenance or making repairs.

- Remain aware of the machine's moving parts. Keep hands, feet, and loose clothing away from the machine's moving parts.
 - Reinstall the safety devices and guards after repair and maintenance procedures are complete.
-

Machine modifications

When servicing or maintaining the machine:

- Use only accessories/attachments that are approved by Wacker Neuson.
 - Do not defeat safety devices.
 - Do not modify the machine without the express written approval of Wacker Neuson.
-

Replacing parts and labels

- Replace worn or damaged components.
 - Replace all missing and hard-to-read labels.
 - When replacing electrical components, use components that are identical in rating and performance to the original components.
 - When replacement parts are required for this machine, use only Wacker Neuson replacement parts or those parts equivalent to the original in all types of specifications, such as physical dimensions, type, strength, and material.
-

Cleaning

When cleaning and servicing the machine:

- Keep machine clean and free of debris such as leaves, paper, cartons, etc.
 - Keep labels legible.
 - Do not clean the machine while it is running.
 - Never use gasoline or other types of fuels or flammable solvents to clean the machine. Fumes from fuels and solvents can become explosive.
-

Personal protective equipment (PPE)

Wear the following personal protective equipment (PPE) while servicing or maintaining this machine:

- Close-fitting work clothes that do not hinder movement
- Safety glasses with side shields
- Hearing protection
- Safety-toed footwear

In addition, before servicing or maintaining the machine:

- Tie back long hair.
 - Remove all jewelry (including rings).
-

Electrical service safety

- Make sure clothing and shoes are dry, stand on a dry wooden platform or rubber insulating mat, and use tools with insulated handles when servicing the machine.
 - Do not allow water to accumulate around the base of the machine. If water is present, move the machine and allow the machine to dry before servicing.
 - Do not pressure wash the control panel, generator end, or any other electrical components when cleaning the machine.
-

Cooling system safety

- Do not attempt to open the radiator cap while the unit is running or before the engine has cooled down. Severe burns may result!
- Engine coolant is toxic to humans and animals. Clean up spills and dispose of waste engine coolant in accordance with local environmental regulations.

1.5 Operator Safety while Using Internal Combustion Engines



WARNING

Internal combustion engines present special hazards during operation and fueling. Failure to follow the warnings and safety standards could result in severe injury or death.

- ▶ Read and follow the warning instructions in the engine owner's manual and the safety guidelines below.



DANGER

Exhaust gas from the engine contains carbon monoxide, a deadly poison. Exposure to carbon monoxide can kill you in minutes.

- ▶ NEVER operate the machine inside an enclosed area, such as a tunnel, unless adequate ventilation is provided through items such as exhaust fans or hoses.

Operating safety

When running the engine:

- Keep the area around the exhaust pipe free of flammable materials.
- Check the fuel lines and the fuel tank for leaks and cracks before starting the engine. Do not run the machine if fuel leaks are present or the fuel lines are loose.
- Do not smoke while operating the machine.
- Do not run the engine near sparks or open flames.
- Do not touch the engine or muffler while the engine is running or immediately after it has been turned off.
- Do not operate a machine when its fuel cap is loose or missing.
- Do not start the engine if fuel has spilled or a fuel odor is present. Move the machine away from the spill and wipe the machine dry before starting.
- Do not use the machine in areas with risk of explosion or fire.

Refueling safety

When refueling the engine:

- Clean up any spilled fuel immediately.
- Refill the fuel tank in a well-ventilated area.
- Reinstall the fuel tank cap after refueling.
- Use tools specifically meant for refueling (for example, a fuel hose or funnel).
- Do not smoke.
- Do not refuel a hot or running engine.
- Do not refuel the engine near sparks or open flames.

1.6 Safety Guidelines for Mobile Generators

**DANGER**

Carbon monoxide. Using a generator indoors CAN KILL YOU IN MINUTES. Generator exhaust contains carbon monoxide (CO). This is a poison you cannot see or smell. If you can smell the generator exhaust, you are breathing CO. Even if you cannot smell the exhaust, you could be breathing CO.

- ▶ NEVER use a generator inside homes, garages, crawlspaces, or other partly enclosed areas. Deadly levels of carbon monoxide can build up in these areas. Using a fan or opening windows and doors does NOT supply enough fresh air.
- ▶ ONLY use a generator outside and far away from windows, doors, and vents. These openings can pull in generator exhaust.
- ▶ Even when you use a generator correctly, CO may leak into the home. ALWAYS use a battery-powered or battery-backup CO alarm in the home.
- ▶ If you start to feel sick, dizzy, or weak after the generator has been running, move to fresh air RIGHT AWAY. See a doctor. You could have carbon monoxide poisoning.

**WARNING**

Electrocution hazard. Machines that generate electric power present special hazards while the engine is running. These include the risk of electrocution or severe electrical shock.

- ▶ Read and follow the instructions in this Operator's Manual.

Installing as backup power

Special hazards exist when installing this machine as a backup power supply. Improper connection of generator to a building's electrical system can allow electrical current from the generator to backfeed into utility lines. This may result in electrocution of utility workers, fire, or explosion.

**WARNING**

Backfeed from the generator into the public power distribution system can cause serious injury or death to utility workers!

- ▶ Connections to a building's electrical system must be made by a qualified electrician and comply with all applicable laws and electrical codes.

If connected to a building's electrical system, the generator must meet the power, voltage, and frequency requirements of the equipment in the building. Differences in power, voltage, and frequency requirements may exist and improper connection may lead to equipment damage, fire, and personal injury or death.

- General safety**
- Do not use evaporative starting fluids to start the engine. They are highly explosive.
 - Do not store items such as excess oil, rags, or tools on top of or inside the machine. These items are a fire hazard and can restrict cooling air.
 - Ensure that electrical cords attached to the machine are in serviceable condition without cuts, cracks, or exposed wires.
 - Do not route electrical cords over vibrating or hot parts of the machine.
 - Do not stand on the machine.
 - Do not enclose or cover the machine when it is use, or when it is hot.

Ground connection

The generator must be connected to a good earthen ground for proper operating safety.

A central “equipment ground” is provided at the customer connection lugs. This point is connected directly to the generator set base. All other system grounds are connected to this central point. Ground the generator in accordance with the standards defined in national, state, and local regulations.

1.7 Safety Guidelines for Towing the Machine



WARNING

Risk of severe injury or death. Improper trailer condition and towing technique can lead to an accident.

- ▶ Obey the instructions below to reduce the risk of an accident.

When towing the machine:

- Do not tow the machine if the towing vehicle’s hitch or the trailer’s coupler are damaged.
- Do not tow the machine if safety chains are damaged.
- Do not tow the machine if any of the trailer’s lug nuts are loose or missing.
- Do not tow the machine if the trailer’s tires have less than 1/16 inch (1.5 mm) of tread.
- Do not tow the machine if trailer tires are underinflated.
- Do not tow the machine unless the trailer’s brakes are functioning properly.
- Do not tow the machine if trailer lighting is not functioning properly.
- Do not exceed the trailer manufacturer’s speed limitations of 89 km/h (55 mph).

When towing the machine:

- Only tow the machine when the trailer’s lug nuts are properly torqued.
- Only tow the machine when the trailer’s tires are properly inflated.
- Only tow the machine when all trailer lights are functioning correctly.
- Only tow the machine when the trailer’s safety chains are connected to the towing vehicle in a crisscross pattern.
- Maintain extra distance between the towing vehicle and other vehicles.
- Avoid soft shoulders, curbs, and sudden lane changes.
- Abide by all licensing requirements for your area.

If you have not driven a towing vehicle with a trailer before, practice turning, stopping, and backing up the towing vehicle with the trailer in an area away from traffic. Only drive the towing vehicle with the trailer when you are confident in your ability to do so.

1.8 Safety Guidelines for Lifting the Machine

When lifting the machine:

- Make sure slings, chains, hooks, ramps, jacks, forklifts, cranes, hoists, and any other type of lifting device used is attached securely and has enough weight-bearing capacity to lift or hold the machine safely. See the *Technical Data* chapter for machine weight.
- Remain aware of the location of other people when lifting the machine.
- Only use the lifting points and tie-downs described in the Operator's Manual.
- Make sure the transporting vehicle has sufficient load capacity and platform size to safely transport the machine.

To reduce the possibility of injury:

- Do not stand under the machine while it is being lifted or moved.
- Do not get onto the machine while it is being lifted or moved.

1.9 Reporting Safety Defects

If you believe your trailer has a defect which could cause a crash or could cause injury or death, you should immediately inform the National Highway Traffic Safety Administration (NHTSA) in addition to notifying Wacker Neuson.

If NHTSA receives similar complaints, it may open an investigation; and if it finds that a safety defect exists in a group of trailers, it may order a recall and remedy campaign. However, NHTSA cannot become involved in individual problems between you, your dealer, or Wacker Neuson.

To contact NHTSA, you may either contact the Vehicle Safety Hotline toll-free at 1-888-327-4236 (TTY: 1-800-424-9153); go to <http://www.safercar.gov>; or write to:

Administrator
NHTSA
1200 New Jersey Avenue S.E.
Washington, DC 20590

You can also obtain other information about your motor vehicle safety from <http://www.safercar.gov>

2 Label Locations

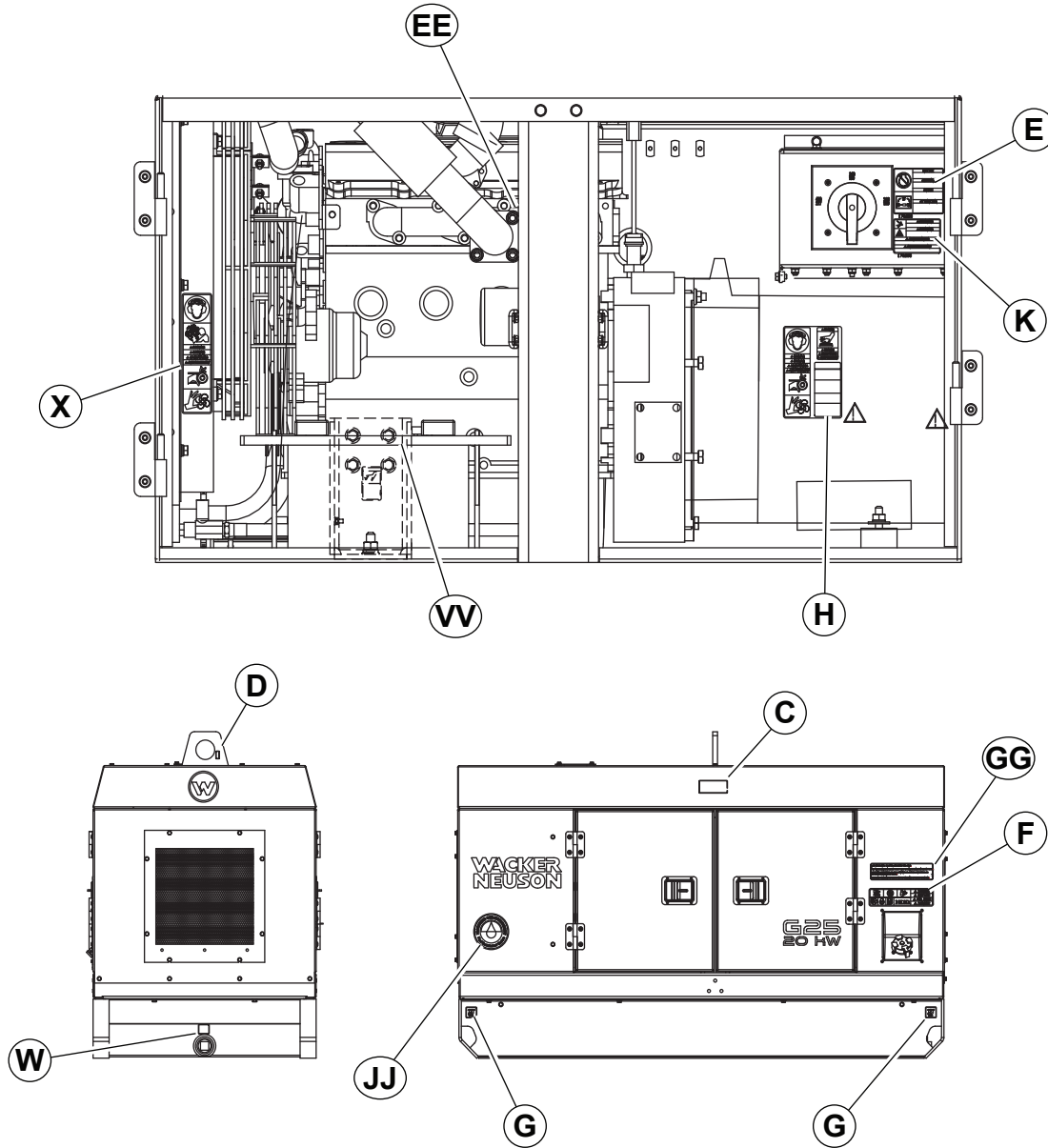



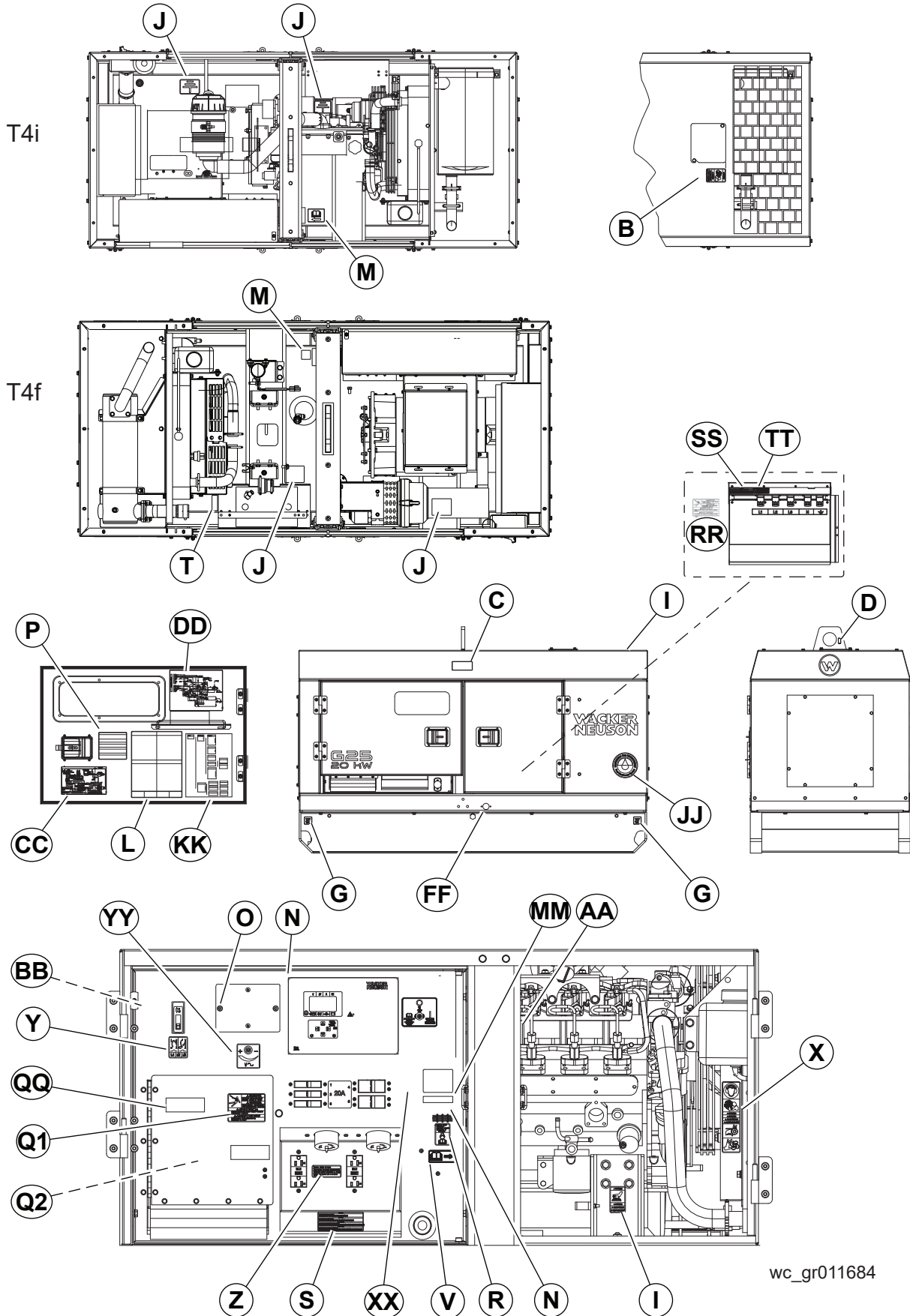

wc_gr011688



wc_gr011684

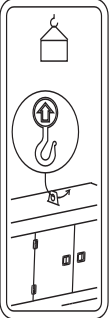
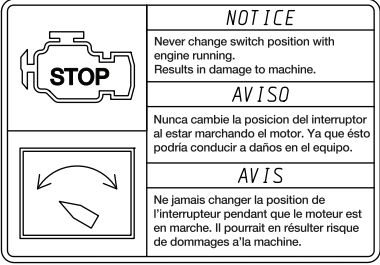

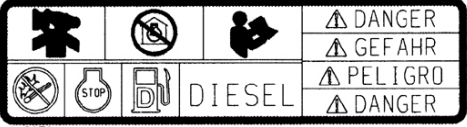
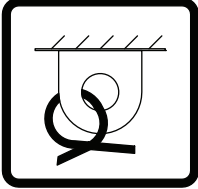
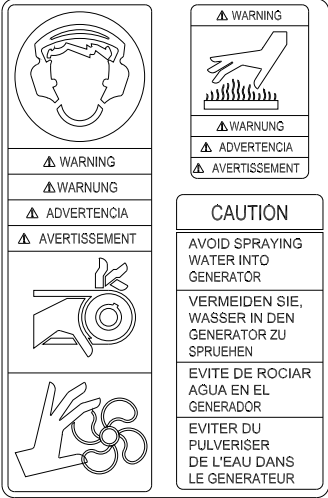
3 Label Meanings

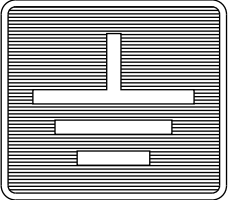

<p>A</p>	<p>(on trailer, if equipped)</p> <table border="1" style="width: 100%; border-collapse: collapse;"> <thead> <tr> <th style="width: 25%;">TOWING INSTRUCTIONS</th> <th style="width: 25%;">ABSCHLEPPINSTRUKTIONEN</th> <th style="width: 25%;">INSTRUCCIONES DE REMOLQUE</th> <th style="width: 25%;">INSTRUCTIONS DE REMORQUAGE</th> </tr> </thead> <tbody> <tr> <td style="font-size: 8px;"> 1. READ OPERATOR'S MANUAL. 2. USE HITCH RATED FOR TRAILERS "GROSS VEHICLE WEIGHT RATING". 3. SECURELY ATTACH TRAILER TO TOW VEHICLE. 4. ATTACH SAFETY CHAINS USING CROSS PATTERN. 5. ATTACH BREAKDOWN CHAIN TO VEHICLE. 6. CHECK TRAILER LIGHTS. </td> <td style="font-size: 8px;"> 1. BETRIEBSVORSCHRIFT LESEN. 2. ANHÄNGEVORRICHTUNG VERWENDEN, DIE DER GESAMTBETRIEBSGEWICHTSKLASSE ENTSPRICHT. 3. ANHÄNGER SICHER AM ZUGFAHRZEUG BEFESTIGEN. 4. SICHERHEITSKETTEN KREUZWEISE ANBRINGEN. 5. ABREISSKETTE AM FAHRZEUG ANBRINGEN. 6. ANHÄNGERLEUCHTEN PRÜFEN. </td> <td style="font-size: 8px;"> 1. LEA EL MANUAL DEL OPERARIO. 2. UTILICE UN ACOPLÉ CORRECTAMENTE CLASIFICADO PARA LA "CLASE DE PESO BRUTO" DEL VEHÍCULO DEL REMOLQUE. 3. ASEGURESE DE AMARRAR CORRECTAMENTE EL REMOLQUE AL VEHÍCULO DE REMOLQUE. 4. FUE EN CRUZ LAS CADENAS DE SEGURIDAD. 5. FUE EN EL VEHÍCULO DE REMOLQUE LA CADENA DE DESPRENDIMIENTO. 6. CONTROLE LAS LUCES DEL REMOLQUE. </td> <td style="font-size: 8px;"> 1. LIRE LA NOTICE D'EMPLOI. 2. UTILISER UN CROCHET D'ATTACHE CONFORME AU DÉBIT NOMINAL DU POIDS BRUT DE VEHICULE DU VEHICULE TRACTEUR. 3. ATTACHER LA REMORQUE FERMEMENT AU VEHICULE TRACTEUR. 4. ATTACHER LES CHAINES DE SURETE EN UTILISANT UNE METHODE CROISEE. 5. ATTACHER LA CHAÎNE DE REMORQUAGE AU VEHICULE. 6. VERIFIER LES LAMPES DE LA REMORQUE. </td> </tr> </tbody> </table>	TOWING INSTRUCTIONS	ABSCHLEPPINSTRUKTIONEN	INSTRUCCIONES DE REMOLQUE	INSTRUCTIONS DE REMORQUAGE	1. READ OPERATOR'S MANUAL. 2. USE HITCH RATED FOR TRAILERS "GROSS VEHICLE WEIGHT RATING". 3. SECURELY ATTACH TRAILER TO TOW VEHICLE. 4. ATTACH SAFETY CHAINS USING CROSS PATTERN. 5. ATTACH BREAKDOWN CHAIN TO VEHICLE. 6. CHECK TRAILER LIGHTS.	1. BETRIEBSVORSCHRIFT LESEN. 2. ANHÄNGEVORRICHTUNG VERWENDEN, DIE DER GESAMTBETRIEBSGEWICHTSKLASSE ENTSPRICHT. 3. ANHÄNGER SICHER AM ZUGFAHRZEUG BEFESTIGEN. 4. SICHERHEITSKETTEN KREUZWEISE ANBRINGEN. 5. ABREISSKETTE AM FAHRZEUG ANBRINGEN. 6. ANHÄNGERLEUCHTEN PRÜFEN.	1. LEA EL MANUAL DEL OPERARIO. 2. UTILICE UN ACOPLÉ CORRECTAMENTE CLASIFICADO PARA LA "CLASE DE PESO BRUTO" DEL VEHÍCULO DEL REMOLQUE. 3. ASEGURESE DE AMARRAR CORRECTAMENTE EL REMOLQUE AL VEHÍCULO DE REMOLQUE. 4. FUE EN CRUZ LAS CADENAS DE SEGURIDAD. 5. FUE EN EL VEHÍCULO DE REMOLQUE LA CADENA DE DESPRENDIMIENTO. 6. CONTROLE LAS LUCES DEL REMOLQUE.	1. LIRE LA NOTICE D'EMPLOI. 2. UTILISER UN CROCHET D'ATTACHE CONFORME AU DÉBIT NOMINAL DU POIDS BRUT DE VEHICULE DU VEHICULE TRACTEUR. 3. ATTACHER LA REMORQUE FERMEMENT AU VEHICULE TRACTEUR. 4. ATTACHER LES CHAINES DE SURETE EN UTILISANT UNE METHODE CROISEE. 5. ATTACHER LA CHAÎNE DE REMORQUAGE AU VEHICULE. 6. VERIFIER LES LAMPES DE LA REMORQUE.
TOWING INSTRUCTIONS	ABSCHLEPPINSTRUKTIONEN	INSTRUCCIONES DE REMOLQUE	INSTRUCTIONS DE REMORQUAGE						
1. READ OPERATOR'S MANUAL. 2. USE HITCH RATED FOR TRAILERS "GROSS VEHICLE WEIGHT RATING". 3. SECURELY ATTACH TRAILER TO TOW VEHICLE. 4. ATTACH SAFETY CHAINS USING CROSS PATTERN. 5. ATTACH BREAKDOWN CHAIN TO VEHICLE. 6. CHECK TRAILER LIGHTS.	1. BETRIEBSVORSCHRIFT LESEN. 2. ANHÄNGEVORRICHTUNG VERWENDEN, DIE DER GESAMTBETRIEBSGEWICHTSKLASSE ENTSPRICHT. 3. ANHÄNGER SICHER AM ZUGFAHRZEUG BEFESTIGEN. 4. SICHERHEITSKETTEN KREUZWEISE ANBRINGEN. 5. ABREISSKETTE AM FAHRZEUG ANBRINGEN. 6. ANHÄNGERLEUCHTEN PRÜFEN.	1. LEA EL MANUAL DEL OPERARIO. 2. UTILICE UN ACOPLÉ CORRECTAMENTE CLASIFICADO PARA LA "CLASE DE PESO BRUTO" DEL VEHÍCULO DEL REMOLQUE. 3. ASEGURESE DE AMARRAR CORRECTAMENTE EL REMOLQUE AL VEHÍCULO DE REMOLQUE. 4. FUE EN CRUZ LAS CADENAS DE SEGURIDAD. 5. FUE EN EL VEHÍCULO DE REMOLQUE LA CADENA DE DESPRENDIMIENTO. 6. CONTROLE LAS LUCES DEL REMOLQUE.	1. LIRE LA NOTICE D'EMPLOI. 2. UTILISER UN CROCHET D'ATTACHE CONFORME AU DÉBIT NOMINAL DU POIDS BRUT DE VEHICULE DU VEHICULE TRACTEUR. 3. ATTACHER LA REMORQUE FERMEMENT AU VEHICULE TRACTEUR. 4. ATTACHER LES CHAINES DE SURETE EN UTILISANT UNE METHODE CROISEE. 5. ATTACHER LA CHAÎNE DE REMORQUAGE AU VEHICULE. 6. VERIFIER LES LAMPES DE LA REMORQUE.						
<p>B</p>	<div style="display: flex; align-items: center;">  <div style="margin-left: 20px;"> <p>WARNING Pressurized contents. Do not open when hot.</p> </div> </div>								
<p>C</p>	<div style="display: flex; align-items: center;">  <div style="margin-left: 20px;"> <p>WARNING Lock doors. Access can cause electric shock or injury. Read the Operator's Manual.</p> </div> </div>								
<p>D</p>	<div style="display: flex; align-items: center;">  <div style="margin-left: 20px;"> <p>NOTICE Lifting point</p> </div> </div>								
<p>E</p>	<div style="display: flex; align-items: center;">  <div style="margin-left: 20px;"> <p>NOTICE Never change switch position with engine running. Results in damage to machine.</p> <p>AVISO Nunca cambie la posición del interruptor al estar marchando el motor. Ya que esto podría conducir a daños en el equipo.</p> <p>AVIS Ne jamais changer la position de l'interrupteur pendant que le moteur est en marche. Il pourrait en résulter risque de dommages à la machine.</p> </div> </div>								

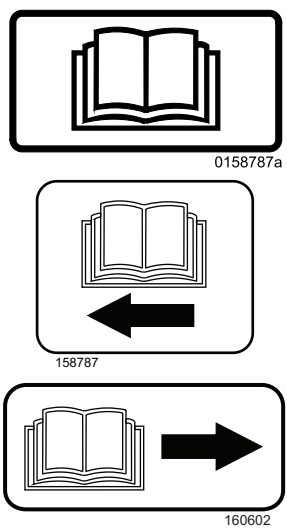

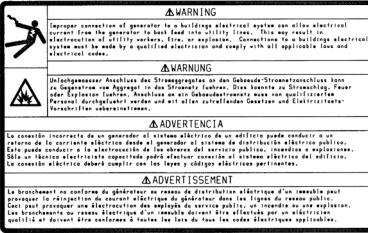
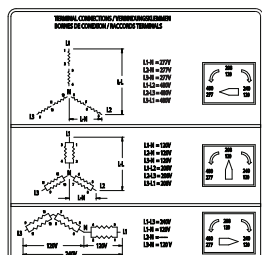
<p>F</p>	 <p>119050</p>	<p>DANGER Asphyxiation hazard. Do not run the machine indoors or in an enclosed area without adequate ventilation. Read the Operator's Manual for instructions. No sparks, flames, or burning objects near machine. Stop the engine before adding fuel. Use only diesel fuel.</p>
<p>G</p>	 <p>113726</p>	<p>Tie-down point</p>
<p>H</p>	 <p>164722</p>	<p>WARNING To prevent hearing loss, wear hearing protection. Hand injury if entangled in moving belt. Rotating machinery! Do not reach inside with engine running. WARNING Hot surface CAUTION Avoid spraying water into generator.</p>
<p>I</p>		<p>WARNING Hot surface</p>
<p>J</p>	 <p>0114886</p>	<p>Electrical ground</p>

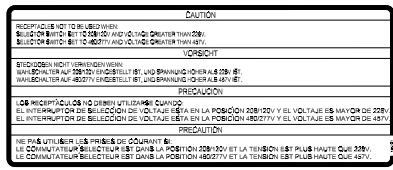

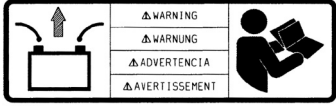
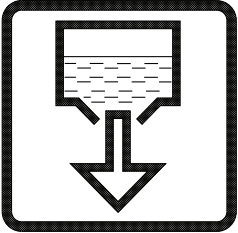

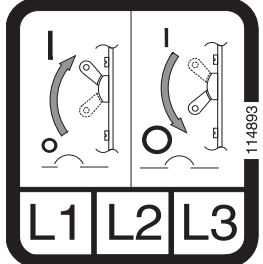
<p>K</p>	 <p>⚠️WARNING Electric shock and arc flash can cause serious injury or death.</p> <p>⚠️ADVERTENCIA Choque eléctrico y arco voltaico de cortocircuito pueden causar heridas personales o muerte.</p> <p>⚠️AVERTISSEMENT Électrochoc et arc de court-circuit peuvent résulter en blessures graves ou mort.</p> <p>176285</p>	<p>WARNING Electric shock and arc flash can cause serious injury or death.</p>											
<p>L</p>	<table border="1"> <thead> <tr> <th data-bbox="381 409 820 472">OPERATING INSTRUCTIONS FOR MOBILE GENERATORS</th> <th data-bbox="820 409 1258 472">BETRIEBSANLEITUNG FÜR MOBILEAGGREGATE</th> </tr> </thead> <tbody> <tr> <td data-bbox="381 472 820 903"> <p>BEFORE STARTING</p> <ol style="list-style-type: none"> 1. READ OPERATOR'S MANUAL. 2. LEVEL UNIT. 3. BLOCK WHEELS. 4. GROUND UNIT. 5. CHECK ALL FLUID LEVELS. <p>MANUAL STARTING</p> <ol style="list-style-type: none"> 1. DISCONNECT ALL EXTERNAL LOADS. 2. SET VOLTAGE SELECTOR SWITCH. 3. LOCK VOLTAGE SELECTOR SWITCH. (*2 & *3 NOT INCLUDED ON G12) 4. TURN EMERGENCY STOP BUTTON TO "ON" POSITION. 5. PUSH ENGINE START SWITCH TO "START/RUN" POSITION. 6. ENGINE WILL MAKE 3 ATTEMPTS TO START. <p>REMOTE START</p> <ol style="list-style-type: none"> 1. SEE OPERATOR'S MANUAL. <p>STOPPING</p> <ol style="list-style-type: none"> 1. DISCONNECT ALL EXTERNAL LOADS. 2. PUSH ENGINE START SWITCH TO "OFF" POSITION. 3. FILL FUEL TANK. </td> <td data-bbox="820 472 1258 903"> <p>VOR DEM STARTEN</p> <ol style="list-style-type: none"> 1. BETRIEBSVORSCHRIFT LESEN. 2. GERÄT WAAGRECHT STELLEN. 3. RÄDER BLOCKIEREN. 4. GERÄT ERDEN. 5. STAND ALLER FLÜSSIGKEITEN PRÜFEN. <p>HANDSTARTEN</p> <ol style="list-style-type: none"> 1. ALLE ÄUSSEREN BELASTUNGEN ABSCHALTEN. 2. SPANNUNGSWAHLSCHALTER SETZEN. 3. SPANNUNGSWAHLSCHALTER VERRIEGELN. (*2 & *3 NICHT EINGESCHLOSSEN MIT G12) 4. NOTSTOPKNOPF IN "ON" POSITION SETZEN. 5. MOTORSTARTSCHALTER AUF POSITION "START/LAUF" DRÜCKEN. 6. MOTOR VOLLZIEHT 3 STARTVERSUCHE. <p>FERNSTART</p> <ol style="list-style-type: none"> 1. SIEHE BETRIEBSVORSCHRIFT. <p>ABSCHALTEN</p> <ol style="list-style-type: none"> 1. ALLE ÄUSSEREN BELASTUNGEN ABSCHALTEN. 2. MOTORSTARTSCHALTER AUF POSITION "OFF" DRÜCKEN. 3. KRAFTSTOFFTANK FÜLLEN. </td> </tr> <tr> <td data-bbox="381 903 820 966"> <p>INSTRUCCIONES PARA LA PUESTA EN MARCHA DE GENERADORES MÓVILES</p> </td> <td data-bbox="820 903 1258 966"> <p>INSTRUCTIONS D'OPERATION DU GENERATEUR MOBILE</p> </td> </tr> <tr> <td data-bbox="381 966 820 1438"> <p>ANTES DEL ARRANQUE</p> <ol style="list-style-type: none"> 1. LEA EL MANUAL DEL OPERARIO. 2. NIVELA LA UNIDAD. 3. COLOQUE CUÑAS DEBAJO DE LAS RUEDAS. 4. CONECTE LA UNIDAD A TIERRA. 5. CONTROLE TODOS LOS LIQUIDOS. <p>ARRANQUE MANUAL</p> <ol style="list-style-type: none"> 1. DESCONECTE TODAS LAS CARGAS EXTERNAS. 2. AJUSTE LA LLAVE SELECTORA DE VOLTAJE. 3. BLOQUEE LA LLAVE SELECTORA DE VOLTAJE. (*2 & *3 NO ESTA INCLUIDO CON G12) 4. GIRE A LA POSICION "ON" EL BOTON DE PARADA DE EMERGENCIA. 5. OPRIMA A LA POSICION "ARRANQUE/MARCHA" EL INTERRUPTOR DE ARRANQUE DEL MOTOR. 6. EL MOTOR INTENTARA ARRANCAR 3 VECES. <p>ARRANQUE REMOTO</p> <ol style="list-style-type: none"> 1. VEA EL MANUAL DEL OPERARIO. <p>DETENCION DEL MOTOR</p> <ol style="list-style-type: none"> 1. DESCONECTE TODAS LAS CARGAS EXTERNAS. 2. OPRIMA A LA POSICION "OFF" EL INTERRUPTOR DE ARRANQUE DEL MOTOR. 3. LLENE EL TANQUE DE COMBUSTIBLE. </td> <td data-bbox="820 966 1258 1438"> <p>AVANT LE DEMARRAGE</p> <ol style="list-style-type: none"> 1. LIRE LA NOTICE D'EMPLOI. 2. NIVELER LA MACHINE. 3. BLOQUER LES ROUES AVEC CALES DE ROUES. 4. METTRE A TERRE LA MACHINE. 5. VERIFIER LE NIVEAU DE TOUS LES FLUIDES. <p>DEMARRAGE A LA MAIN</p> <ol style="list-style-type: none"> 1. DECONNECTER TOUS LES REGIMES EXTERNES. 2. REGLER LE COMMUTATEUR DES TENSIONS D'ALIMENTATION. 3. SERRER LE COMMUTATEUR DES TENSIONS D'ALIMENTATION. (*2 & *3 PAS COMPRIS AVEC G12) 4. TOURNER LE BOUTON D'ARRET D'URGENCE A LA POSITION "ON". 5. PRESSER L'INTERRUPTEUR DE DEMARRAGE DU MOTEUR A LA POSITION "DEMARRAGE/MARCHE". 6. LE MOTEUR S'ESSAYERA DE DEMARRER 3 FOIS. <p>DEMARRAGE A DISTANCE</p> <ol style="list-style-type: none"> 1. LIRE LA NOTICE D'EMPLOI. <p>ARRET</p> <ol style="list-style-type: none"> 1. DECONNECTER TOUS LES REGIMES EXTERNES. 2. PRESSER L'INTERRUPTEUR DE DEMARRAGE DU MOTEUR A LA POSITION "OFF". 3. REMPLIR LE RESERVOIR A CARBURANT. </td> </tr> <tr> <td data-bbox="381 1438 609 1543"> <p>OPERATOR'S MANUAL MUST BE STORED ON MACHINE. REPLACEMENT OPERATOR'S MANUAL CAN BE ORDERED THROUGH YOUR LOCAL WACKER DISTRIBUTOR.</p> </td> <td data-bbox="609 1438 820 1543"> <p>DIE BETRIEBSVORSCHRIFT MUSS AN DER MASCHINE AUFBEWAHRT WERDEN. ZUR BESTELLUNG VON ERSATZBÜCHERN WENDEN SIE SICH BITTE AN IHREN ÜRTLICHEN WACKER HÄNDLER.</p> </td> <td data-bbox="820 1438 1258 1543"> <p>EL MANUAL DE OPERACION DEBE SER RETENIDO EN LA MAQUINA. CONTACTE A SU DISTRIBUIDOR WACKER MAS CERCAÑO PARA PEDIR UN EJEMPLAR ADICIONAL.</p> <p>LA NOTICE D'EMPLOI DOIT ETRE MUNIE SUR LA MACHINE. CONTACTER LE DISTRIBUTEUR WACKER LE PLUS PROCHE POUR COMMANDER UN EXEMPLAIRE SUPPLEMENTAIRE.</p> </td> </tr> </tbody> </table> <p>164720</p>		OPERATING INSTRUCTIONS FOR MOBILE GENERATORS	BETRIEBSANLEITUNG FÜR MOBILEAGGREGATE	<p>BEFORE STARTING</p> <ol style="list-style-type: none"> 1. READ OPERATOR'S MANUAL. 2. LEVEL UNIT. 3. BLOCK WHEELS. 4. GROUND UNIT. 5. CHECK ALL FLUID LEVELS. <p>MANUAL STARTING</p> <ol style="list-style-type: none"> 1. DISCONNECT ALL EXTERNAL LOADS. 2. SET VOLTAGE SELECTOR SWITCH. 3. LOCK VOLTAGE SELECTOR SWITCH. (*2 & *3 NOT INCLUDED ON G12) 4. TURN EMERGENCY STOP BUTTON TO "ON" POSITION. 5. PUSH ENGINE START SWITCH TO "START/RUN" POSITION. 6. ENGINE WILL MAKE 3 ATTEMPTS TO START. <p>REMOTE START</p> <ol style="list-style-type: none"> 1. SEE OPERATOR'S MANUAL. <p>STOPPING</p> <ol style="list-style-type: none"> 1. DISCONNECT ALL EXTERNAL LOADS. 2. PUSH ENGINE START SWITCH TO "OFF" POSITION. 3. FILL FUEL TANK. 	<p>VOR DEM STARTEN</p> <ol style="list-style-type: none"> 1. BETRIEBSVORSCHRIFT LESEN. 2. GERÄT WAAGRECHT STELLEN. 3. RÄDER BLOCKIEREN. 4. GERÄT ERDEN. 5. STAND ALLER FLÜSSIGKEITEN PRÜFEN. <p>HANDSTARTEN</p> <ol style="list-style-type: none"> 1. ALLE ÄUSSEREN BELASTUNGEN ABSCHALTEN. 2. SPANNUNGSWAHLSCHALTER SETZEN. 3. SPANNUNGSWAHLSCHALTER VERRIEGELN. (*2 & *3 NICHT EINGESCHLOSSEN MIT G12) 4. NOTSTOPKNOPF IN "ON" POSITION SETZEN. 5. MOTORSTARTSCHALTER AUF POSITION "START/LAUF" DRÜCKEN. 6. MOTOR VOLLZIEHT 3 STARTVERSUCHE. <p>FERNSTART</p> <ol style="list-style-type: none"> 1. SIEHE BETRIEBSVORSCHRIFT. <p>ABSCHALTEN</p> <ol style="list-style-type: none"> 1. ALLE ÄUSSEREN BELASTUNGEN ABSCHALTEN. 2. MOTORSTARTSCHALTER AUF POSITION "OFF" DRÜCKEN. 3. KRAFTSTOFFTANK FÜLLEN. 	<p>INSTRUCCIONES PARA LA PUESTA EN MARCHA DE GENERADORES MÓVILES</p>	<p>INSTRUCTIONS D'OPERATION DU GENERATEUR MOBILE</p>	<p>ANTES DEL ARRANQUE</p> <ol style="list-style-type: none"> 1. LEA EL MANUAL DEL OPERARIO. 2. NIVELA LA UNIDAD. 3. COLOQUE CUÑAS DEBAJO DE LAS RUEDAS. 4. CONECTE LA UNIDAD A TIERRA. 5. CONTROLE TODOS LOS LIQUIDOS. <p>ARRANQUE MANUAL</p> <ol style="list-style-type: none"> 1. DESCONECTE TODAS LAS CARGAS EXTERNAS. 2. AJUSTE LA LLAVE SELECTORA DE VOLTAJE. 3. BLOQUEE LA LLAVE SELECTORA DE VOLTAJE. (*2 & *3 NO ESTA INCLUIDO CON G12) 4. GIRE A LA POSICION "ON" EL BOTON DE PARADA DE EMERGENCIA. 5. OPRIMA A LA POSICION "ARRANQUE/MARCHA" EL INTERRUPTOR DE ARRANQUE DEL MOTOR. 6. EL MOTOR INTENTARA ARRANCAR 3 VECES. <p>ARRANQUE REMOTO</p> <ol style="list-style-type: none"> 1. VEA EL MANUAL DEL OPERARIO. <p>DETENCION DEL MOTOR</p> <ol style="list-style-type: none"> 1. DESCONECTE TODAS LAS CARGAS EXTERNAS. 2. OPRIMA A LA POSICION "OFF" EL INTERRUPTOR DE ARRANQUE DEL MOTOR. 3. LLENE EL TANQUE DE COMBUSTIBLE. 	<p>AVANT LE DEMARRAGE</p> <ol style="list-style-type: none"> 1. LIRE LA NOTICE D'EMPLOI. 2. NIVELER LA MACHINE. 3. BLOQUER LES ROUES AVEC CALES DE ROUES. 4. METTRE A TERRE LA MACHINE. 5. VERIFIER LE NIVEAU DE TOUS LES FLUIDES. <p>DEMARRAGE A LA MAIN</p> <ol style="list-style-type: none"> 1. DECONNECTER TOUS LES REGIMES EXTERNES. 2. REGLER LE COMMUTATEUR DES TENSIONS D'ALIMENTATION. 3. SERRER LE COMMUTATEUR DES TENSIONS D'ALIMENTATION. (*2 & *3 PAS COMPRIS AVEC G12) 4. TOURNER LE BOUTON D'ARRET D'URGENCE A LA POSITION "ON". 5. PRESSER L'INTERRUPTEUR DE DEMARRAGE DU MOTEUR A LA POSITION "DEMARRAGE/MARCHE". 6. LE MOTEUR S'ESSAYERA DE DEMARRER 3 FOIS. <p>DEMARRAGE A DISTANCE</p> <ol style="list-style-type: none"> 1. LIRE LA NOTICE D'EMPLOI. <p>ARRET</p> <ol style="list-style-type: none"> 1. DECONNECTER TOUS LES REGIMES EXTERNES. 2. PRESSER L'INTERRUPTEUR DE DEMARRAGE DU MOTEUR A LA POSITION "OFF". 3. REMPLIR LE RESERVOIR A CARBURANT. 	<p>OPERATOR'S MANUAL MUST BE STORED ON MACHINE. REPLACEMENT OPERATOR'S MANUAL CAN BE ORDERED THROUGH YOUR LOCAL WACKER DISTRIBUTOR.</p>	<p>DIE BETRIEBSVORSCHRIFT MUSS AN DER MASCHINE AUFBEWAHRT WERDEN. ZUR BESTELLUNG VON ERSATZBÜCHERN WENDEN SIE SICH BITTE AN IHREN ÜRTLICHEN WACKER HÄNDLER.</p>	<p>EL MANUAL DE OPERACION DEBE SER RETENIDO EN LA MAQUINA. CONTACTE A SU DISTRIBUIDOR WACKER MAS CERCAÑO PARA PEDIR UN EJEMPLAR ADICIONAL.</p> <p>LA NOTICE D'EMPLOI DOIT ETRE MUNIE SUR LA MACHINE. CONTACTER LE DISTRIBUTEUR WACKER LE PLUS PROCHE POUR COMMANDER UN EXEMPLAIRE SUPPLEMENTAIRE.</p>
OPERATING INSTRUCTIONS FOR MOBILE GENERATORS	BETRIEBSANLEITUNG FÜR MOBILEAGGREGATE												
<p>BEFORE STARTING</p> <ol style="list-style-type: none"> 1. READ OPERATOR'S MANUAL. 2. LEVEL UNIT. 3. BLOCK WHEELS. 4. GROUND UNIT. 5. CHECK ALL FLUID LEVELS. <p>MANUAL STARTING</p> <ol style="list-style-type: none"> 1. DISCONNECT ALL EXTERNAL LOADS. 2. SET VOLTAGE SELECTOR SWITCH. 3. LOCK VOLTAGE SELECTOR SWITCH. (*2 & *3 NOT INCLUDED ON G12) 4. TURN EMERGENCY STOP BUTTON TO "ON" POSITION. 5. PUSH ENGINE START SWITCH TO "START/RUN" POSITION. 6. ENGINE WILL MAKE 3 ATTEMPTS TO START. <p>REMOTE START</p> <ol style="list-style-type: none"> 1. SEE OPERATOR'S MANUAL. <p>STOPPING</p> <ol style="list-style-type: none"> 1. DISCONNECT ALL EXTERNAL LOADS. 2. PUSH ENGINE START SWITCH TO "OFF" POSITION. 3. FILL FUEL TANK. 	<p>VOR DEM STARTEN</p> <ol style="list-style-type: none"> 1. BETRIEBSVORSCHRIFT LESEN. 2. GERÄT WAAGRECHT STELLEN. 3. RÄDER BLOCKIEREN. 4. GERÄT ERDEN. 5. STAND ALLER FLÜSSIGKEITEN PRÜFEN. <p>HANDSTARTEN</p> <ol style="list-style-type: none"> 1. ALLE ÄUSSEREN BELASTUNGEN ABSCHALTEN. 2. SPANNUNGSWAHLSCHALTER SETZEN. 3. SPANNUNGSWAHLSCHALTER VERRIEGELN. (*2 & *3 NICHT EINGESCHLOSSEN MIT G12) 4. NOTSTOPKNOPF IN "ON" POSITION SETZEN. 5. MOTORSTARTSCHALTER AUF POSITION "START/LAUF" DRÜCKEN. 6. MOTOR VOLLZIEHT 3 STARTVERSUCHE. <p>FERNSTART</p> <ol style="list-style-type: none"> 1. SIEHE BETRIEBSVORSCHRIFT. <p>ABSCHALTEN</p> <ol style="list-style-type: none"> 1. ALLE ÄUSSEREN BELASTUNGEN ABSCHALTEN. 2. MOTORSTARTSCHALTER AUF POSITION "OFF" DRÜCKEN. 3. KRAFTSTOFFTANK FÜLLEN. 												
<p>INSTRUCCIONES PARA LA PUESTA EN MARCHA DE GENERADORES MÓVILES</p>	<p>INSTRUCTIONS D'OPERATION DU GENERATEUR MOBILE</p>												
<p>ANTES DEL ARRANQUE</p> <ol style="list-style-type: none"> 1. LEA EL MANUAL DEL OPERARIO. 2. NIVELA LA UNIDAD. 3. COLOQUE CUÑAS DEBAJO DE LAS RUEDAS. 4. CONECTE LA UNIDAD A TIERRA. 5. CONTROLE TODOS LOS LIQUIDOS. <p>ARRANQUE MANUAL</p> <ol style="list-style-type: none"> 1. DESCONECTE TODAS LAS CARGAS EXTERNAS. 2. AJUSTE LA LLAVE SELECTORA DE VOLTAJE. 3. BLOQUEE LA LLAVE SELECTORA DE VOLTAJE. (*2 & *3 NO ESTA INCLUIDO CON G12) 4. GIRE A LA POSICION "ON" EL BOTON DE PARADA DE EMERGENCIA. 5. OPRIMA A LA POSICION "ARRANQUE/MARCHA" EL INTERRUPTOR DE ARRANQUE DEL MOTOR. 6. EL MOTOR INTENTARA ARRANCAR 3 VECES. <p>ARRANQUE REMOTO</p> <ol style="list-style-type: none"> 1. VEA EL MANUAL DEL OPERARIO. <p>DETENCION DEL MOTOR</p> <ol style="list-style-type: none"> 1. DESCONECTE TODAS LAS CARGAS EXTERNAS. 2. OPRIMA A LA POSICION "OFF" EL INTERRUPTOR DE ARRANQUE DEL MOTOR. 3. LLENE EL TANQUE DE COMBUSTIBLE. 	<p>AVANT LE DEMARRAGE</p> <ol style="list-style-type: none"> 1. LIRE LA NOTICE D'EMPLOI. 2. NIVELER LA MACHINE. 3. BLOQUER LES ROUES AVEC CALES DE ROUES. 4. METTRE A TERRE LA MACHINE. 5. VERIFIER LE NIVEAU DE TOUS LES FLUIDES. <p>DEMARRAGE A LA MAIN</p> <ol style="list-style-type: none"> 1. DECONNECTER TOUS LES REGIMES EXTERNES. 2. REGLER LE COMMUTATEUR DES TENSIONS D'ALIMENTATION. 3. SERRER LE COMMUTATEUR DES TENSIONS D'ALIMENTATION. (*2 & *3 PAS COMPRIS AVEC G12) 4. TOURNER LE BOUTON D'ARRET D'URGENCE A LA POSITION "ON". 5. PRESSER L'INTERRUPTEUR DE DEMARRAGE DU MOTEUR A LA POSITION "DEMARRAGE/MARCHE". 6. LE MOTEUR S'ESSAYERA DE DEMARRER 3 FOIS. <p>DEMARRAGE A DISTANCE</p> <ol style="list-style-type: none"> 1. LIRE LA NOTICE D'EMPLOI. <p>ARRET</p> <ol style="list-style-type: none"> 1. DECONNECTER TOUS LES REGIMES EXTERNES. 2. PRESSER L'INTERRUPTEUR DE DEMARRAGE DU MOTEUR A LA POSITION "OFF". 3. REMPLIR LE RESERVOIR A CARBURANT. 												
<p>OPERATOR'S MANUAL MUST BE STORED ON MACHINE. REPLACEMENT OPERATOR'S MANUAL CAN BE ORDERED THROUGH YOUR LOCAL WACKER DISTRIBUTOR.</p>	<p>DIE BETRIEBSVORSCHRIFT MUSS AN DER MASCHINE AUFBEWAHRT WERDEN. ZUR BESTELLUNG VON ERSATZBÜCHERN WENDEN SIE SICH BITTE AN IHREN ÜRTLICHEN WACKER HÄNDLER.</p>	<p>EL MANUAL DE OPERACION DEBE SER RETENIDO EN LA MAQUINA. CONTACTE A SU DISTRIBUIDOR WACKER MAS CERCAÑO PARA PEDIR UN EJEMPLAR ADICIONAL.</p> <p>LA NOTICE D'EMPLOI DOIT ETRE MUNIE SUR LA MACHINE. CONTACTER LE DISTRIBUTEUR WACKER LE PLUS PROCHE POUR COMMANDER UN EXEMPLAIRE SUPPLEMENTAIRE.</p>											

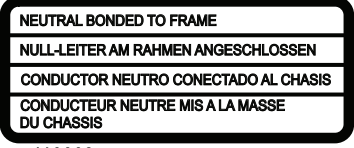
<p>L</p>	<table border="1"> <thead> <tr> <th data-bbox="391 201 662 260">OPERATING INSTRUCTIONS FOR MOBILE GENERATORS</th> <th data-bbox="662 201 933 260">INSTRUCCIONES PARA LA PUESTA EN MARCHA DE GENERADORES MOVILES</th> <th data-bbox="933 201 1198 260">INSTRUCTIONS D'OPERATION DU GENERATEUR MOBILE</th> </tr> </thead> <tbody> <tr> <td data-bbox="391 260 662 842"> <p>BEFORE STARTING</p> <ol style="list-style-type: none"> 1. READ OPERATOR'S MANUAL. 2. LEVEL UNIT. 3. BLOCK WHEELS. 4. GROUND UNIT. 5. CHECK ALL FLUID LEVELS. <p>MANUAL STARTING</p> <ol style="list-style-type: none"> 1. DISCONNECT ALL EXTERNAL LOADS. 2. SET VOLTAGE SELECTOR SWITCH. 3. LOCK VOLTAGE SELECTOR SWITCH. 4. TURN EMERGENCY STOP BUTTON TO "ON" POSITION. 5. PUSH CONTROLLER POWER POWER SWITCH TO "ON" POSITION. 6. PUSH MANUAL MODE BUTTON. 7. PUSH START BUTTON. 8. ENGINE WILL MAKE 3 ATTEMPTS TO START. <p>REMOTE START</p> <ol style="list-style-type: none"> 1. SEE OPERATOR'S MANUAL. <p>STOPPING</p> <ol style="list-style-type: none"> 1. DISCONNECT ALL EXTERNAL LOADS. 2. PUSH STOP BUTTON. 3. PUSH CONTROLLER POWER SWITCH TO "OFF" POSITION. 4. FILL FUEL TANK. </td> <td data-bbox="662 260 933 842"> <p>ANTES DEL ARRANQUE</p> <ol style="list-style-type: none"> 1. LEA EL MANUAL DEL OPERARIO. 2. NIVEL LA UNIDAD. 3. COLOQUE CUÑAS DEBAJO DE LAS RUEDAS. 4. CONECTE LA UNIDAD A TIERRA. 5. CONTROLE TODOS LOS LIQUIDOS. <p>ARRANQUE MANUAL</p> <ol style="list-style-type: none"> 1. DESCONECTE TODAS LAS CARGAS EXTERNAS. 2. AJUSTE LA LLAVE SELECTORA DE VOLTAJE. 3. BLOQUEE LA LLAVE SELECTORA DE VOLTAJE. 4. GIRE A LA POSICION "ON" EL BOTON DE PARADA DE EMERGENCIA. 5. APRIETE EL INTERRUPTOR DE CONTROLADOR A LA POSICION "ON". 6. APRIETE EL BOTON DE MODO MANUEL. 7. APRIETE EL BOTON DE ARRANQUE. 8. EL MOTOR INTENTARA ARRANCAR 3 VECES. <p>ARRANQUE REMOTO</p> <ol style="list-style-type: none"> 1. VEA EL MANUAL DEL OPERARIO. <p>DETECCION DEL MOTOR</p> <ol style="list-style-type: none"> 1. DESCONECTE TODAS LAS CARGAS EXTERNAS. 2. APRIETE EL BOTON DE PARADA. 3. APRIETE EL INTERRUPTOR DE CONTROLADOR A LA POSICION "OFF". 4. LLENE EL TANQUE DE COMBUSTIBLE. </td> <td data-bbox="933 260 1198 842"> <p>AVANT LE DEMARRAGE</p> <ol style="list-style-type: none"> 1. LIRE LA NOTICE D'EMPLOI 2. NIVELER LA MACHINE. 3. BLOQUER LES ROUES AVEC CALES DE ROUES. 4. METTRE A TERRE LA MACHINE. 5. VERIFIER LE NIVEAU DE TOUS LES FLUIDES. <p>DEMARRAGE A LA MAIN</p> <ol style="list-style-type: none"> 1. DECONNECTER TOUS LES REGIMES EXTERNES. 2. REGLER LE COMMUTATEUR DES TENSIONS D'ALIMENTATION. 3. SERRER LE COMMUTATEUR DES TENSIONS D'ALIMENTATION. 4. TOURNER LE BOUTON D'ARRET D'URGENCE. A LA POSITION "ON". 5. PRESSER L'INTERRUPTEUR DE CONTROLÉUR A LA POSITION "ON". 6. PRESSER LE BOUTON DE MODE MANUEL. 7. PRESSER LE BOUTON DE DEMARRAGE. 8. LE MOTEUR S'ESSAYERA DE DEMARRER 3 FOIS. <p>DEMARRAGE A DISTANCE</p> <ol style="list-style-type: none"> 1. LIRE LA NOTICE D'EMPLOI. <p>ARRET</p> <ol style="list-style-type: none"> 1. DECONNECTER TOUS LES REGIMES EXTERNES. 2. PRESSER LE BOUTON D'ARRÊT. 3. PRESSER L'INTERRUPTEUR DE CONTROLÉUR A LA POSITION "OFF". 4. REMPLIR LE RESERVOIR A CARBURANT. </td> </tr> <tr> <td data-bbox="391 842 662 957"> <p>OPERATOR'S MANUAL MUST BE STORED ON MACHINE. A REPLACEMENT OPERATOR'S MANUAL CAN BE ORDERED THROUGH WACKER NEUSON OR ONLINE AT WWW.WACKERNEUSON.COM.</p> </td> <td data-bbox="662 842 933 957"> <p>EL MANUAL DE OPERACION DEBE SER RETENIDO EN LA MÁQUINA. CONTACTE A WACKER NEUSON PARA UN EJEMPLAR ADICIONAL O PONGA UNA ORDEN EN LINEA EN WWW.WACKERNEUSON.COM.</p> </td> <td data-bbox="933 842 1198 957"> <p>LA NOTICE D'EMPLOI DOIT ÊTRE MUNIE SUR LA MACHINE. CONTACTER WACKER NEUSON POUR COMMANDER UN EXEMPLAIRE SUPPLEMENTAIRE OU COMMANDER EN LIGNE CHEZ WWW.WACKERNEUSON.COM.</p> </td> </tr> </tbody> </table>	OPERATING INSTRUCTIONS FOR MOBILE GENERATORS	INSTRUCCIONES PARA LA PUESTA EN MARCHA DE GENERADORES MOVILES	INSTRUCTIONS D'OPERATION DU GENERATEUR MOBILE	<p>BEFORE STARTING</p> <ol style="list-style-type: none"> 1. READ OPERATOR'S MANUAL. 2. LEVEL UNIT. 3. BLOCK WHEELS. 4. GROUND UNIT. 5. CHECK ALL FLUID LEVELS. <p>MANUAL STARTING</p> <ol style="list-style-type: none"> 1. DISCONNECT ALL EXTERNAL LOADS. 2. SET VOLTAGE SELECTOR SWITCH. 3. LOCK VOLTAGE SELECTOR SWITCH. 4. TURN EMERGENCY STOP BUTTON TO "ON" POSITION. 5. PUSH CONTROLLER POWER POWER SWITCH TO "ON" POSITION. 6. PUSH MANUAL MODE BUTTON. 7. PUSH START BUTTON. 8. ENGINE WILL MAKE 3 ATTEMPTS TO START. <p>REMOTE START</p> <ol style="list-style-type: none"> 1. SEE OPERATOR'S MANUAL. <p>STOPPING</p> <ol style="list-style-type: none"> 1. DISCONNECT ALL EXTERNAL LOADS. 2. PUSH STOP BUTTON. 3. PUSH CONTROLLER POWER SWITCH TO "OFF" POSITION. 4. FILL FUEL TANK. 	<p>ANTES DEL ARRANQUE</p> <ol style="list-style-type: none"> 1. LEA EL MANUAL DEL OPERARIO. 2. NIVEL LA UNIDAD. 3. COLOQUE CUÑAS DEBAJO DE LAS RUEDAS. 4. CONECTE LA UNIDAD A TIERRA. 5. CONTROLE TODOS LOS LIQUIDOS. <p>ARRANQUE MANUAL</p> <ol style="list-style-type: none"> 1. DESCONECTE TODAS LAS CARGAS EXTERNAS. 2. AJUSTE LA LLAVE SELECTORA DE VOLTAJE. 3. BLOQUEE LA LLAVE SELECTORA DE VOLTAJE. 4. GIRE A LA POSICION "ON" EL BOTON DE PARADA DE EMERGENCIA. 5. APRIETE EL INTERRUPTOR DE CONTROLADOR A LA POSICION "ON". 6. APRIETE EL BOTON DE MODO MANUEL. 7. APRIETE EL BOTON DE ARRANQUE. 8. EL MOTOR INTENTARA ARRANCAR 3 VECES. <p>ARRANQUE REMOTO</p> <ol style="list-style-type: none"> 1. VEA EL MANUAL DEL OPERARIO. <p>DETECCION DEL MOTOR</p> <ol style="list-style-type: none"> 1. DESCONECTE TODAS LAS CARGAS EXTERNAS. 2. APRIETE EL BOTON DE PARADA. 3. APRIETE EL INTERRUPTOR DE CONTROLADOR A LA POSICION "OFF". 4. LLENE EL TANQUE DE COMBUSTIBLE. 	<p>AVANT LE DEMARRAGE</p> <ol style="list-style-type: none"> 1. LIRE LA NOTICE D'EMPLOI 2. NIVELER LA MACHINE. 3. BLOQUER LES ROUES AVEC CALES DE ROUES. 4. METTRE A TERRE LA MACHINE. 5. VERIFIER LE NIVEAU DE TOUS LES FLUIDES. <p>DEMARRAGE A LA MAIN</p> <ol style="list-style-type: none"> 1. DECONNECTER TOUS LES REGIMES EXTERNES. 2. REGLER LE COMMUTATEUR DES TENSIONS D'ALIMENTATION. 3. SERRER LE COMMUTATEUR DES TENSIONS D'ALIMENTATION. 4. TOURNER LE BOUTON D'ARRET D'URGENCE. A LA POSITION "ON". 5. PRESSER L'INTERRUPTEUR DE CONTROLÉUR A LA POSITION "ON". 6. PRESSER LE BOUTON DE MODE MANUEL. 7. PRESSER LE BOUTON DE DEMARRAGE. 8. LE MOTEUR S'ESSAYERA DE DEMARRER 3 FOIS. <p>DEMARRAGE A DISTANCE</p> <ol style="list-style-type: none"> 1. LIRE LA NOTICE D'EMPLOI. <p>ARRET</p> <ol style="list-style-type: none"> 1. DECONNECTER TOUS LES REGIMES EXTERNES. 2. PRESSER LE BOUTON D'ARRÊT. 3. PRESSER L'INTERRUPTEUR DE CONTROLÉUR A LA POSITION "OFF". 4. REMPLIR LE RESERVOIR A CARBURANT. 	<p>OPERATOR'S MANUAL MUST BE STORED ON MACHINE. A REPLACEMENT OPERATOR'S MANUAL CAN BE ORDERED THROUGH WACKER NEUSON OR ONLINE AT WWW.WACKERNEUSON.COM.</p>	<p>EL MANUAL DE OPERACION DEBE SER RETENIDO EN LA MÁQUINA. CONTACTE A WACKER NEUSON PARA UN EJEMPLAR ADICIONAL O PONGA UNA ORDEN EN LINEA EN WWW.WACKERNEUSON.COM.</p>	<p>LA NOTICE D'EMPLOI DOIT ÊTRE MUNIE SUR LA MACHINE. CONTACTER WACKER NEUSON POUR COMMANDER UN EXEMPLAIRE SUPPLEMENTAIRE OU COMMANDER EN LIGNE CHEZ WWW.WACKERNEUSON.COM.</p>
OPERATING INSTRUCTIONS FOR MOBILE GENERATORS	INSTRUCCIONES PARA LA PUESTA EN MARCHA DE GENERADORES MOVILES	INSTRUCTIONS D'OPERATION DU GENERATEUR MOBILE								
<p>BEFORE STARTING</p> <ol style="list-style-type: none"> 1. READ OPERATOR'S MANUAL. 2. LEVEL UNIT. 3. BLOCK WHEELS. 4. GROUND UNIT. 5. CHECK ALL FLUID LEVELS. <p>MANUAL STARTING</p> <ol style="list-style-type: none"> 1. DISCONNECT ALL EXTERNAL LOADS. 2. SET VOLTAGE SELECTOR SWITCH. 3. LOCK VOLTAGE SELECTOR SWITCH. 4. TURN EMERGENCY STOP BUTTON TO "ON" POSITION. 5. PUSH CONTROLLER POWER POWER SWITCH TO "ON" POSITION. 6. PUSH MANUAL MODE BUTTON. 7. PUSH START BUTTON. 8. ENGINE WILL MAKE 3 ATTEMPTS TO START. <p>REMOTE START</p> <ol style="list-style-type: none"> 1. SEE OPERATOR'S MANUAL. <p>STOPPING</p> <ol style="list-style-type: none"> 1. DISCONNECT ALL EXTERNAL LOADS. 2. PUSH STOP BUTTON. 3. PUSH CONTROLLER POWER SWITCH TO "OFF" POSITION. 4. FILL FUEL TANK. 	<p>ANTES DEL ARRANQUE</p> <ol style="list-style-type: none"> 1. LEA EL MANUAL DEL OPERARIO. 2. NIVEL LA UNIDAD. 3. COLOQUE CUÑAS DEBAJO DE LAS RUEDAS. 4. CONECTE LA UNIDAD A TIERRA. 5. CONTROLE TODOS LOS LIQUIDOS. <p>ARRANQUE MANUAL</p> <ol style="list-style-type: none"> 1. DESCONECTE TODAS LAS CARGAS EXTERNAS. 2. AJUSTE LA LLAVE SELECTORA DE VOLTAJE. 3. BLOQUEE LA LLAVE SELECTORA DE VOLTAJE. 4. GIRE A LA POSICION "ON" EL BOTON DE PARADA DE EMERGENCIA. 5. APRIETE EL INTERRUPTOR DE CONTROLADOR A LA POSICION "ON". 6. APRIETE EL BOTON DE MODO MANUEL. 7. APRIETE EL BOTON DE ARRANQUE. 8. EL MOTOR INTENTARA ARRANCAR 3 VECES. <p>ARRANQUE REMOTO</p> <ol style="list-style-type: none"> 1. VEA EL MANUAL DEL OPERARIO. <p>DETECCION DEL MOTOR</p> <ol style="list-style-type: none"> 1. DESCONECTE TODAS LAS CARGAS EXTERNAS. 2. APRIETE EL BOTON DE PARADA. 3. APRIETE EL INTERRUPTOR DE CONTROLADOR A LA POSICION "OFF". 4. LLENE EL TANQUE DE COMBUSTIBLE. 	<p>AVANT LE DEMARRAGE</p> <ol style="list-style-type: none"> 1. LIRE LA NOTICE D'EMPLOI 2. NIVELER LA MACHINE. 3. BLOQUER LES ROUES AVEC CALES DE ROUES. 4. METTRE A TERRE LA MACHINE. 5. VERIFIER LE NIVEAU DE TOUS LES FLUIDES. <p>DEMARRAGE A LA MAIN</p> <ol style="list-style-type: none"> 1. DECONNECTER TOUS LES REGIMES EXTERNES. 2. REGLER LE COMMUTATEUR DES TENSIONS D'ALIMENTATION. 3. SERRER LE COMMUTATEUR DES TENSIONS D'ALIMENTATION. 4. TOURNER LE BOUTON D'ARRET D'URGENCE. A LA POSITION "ON". 5. PRESSER L'INTERRUPTEUR DE CONTROLÉUR A LA POSITION "ON". 6. PRESSER LE BOUTON DE MODE MANUEL. 7. PRESSER LE BOUTON DE DEMARRAGE. 8. LE MOTEUR S'ESSAYERA DE DEMARRER 3 FOIS. <p>DEMARRAGE A DISTANCE</p> <ol style="list-style-type: none"> 1. LIRE LA NOTICE D'EMPLOI. <p>ARRET</p> <ol style="list-style-type: none"> 1. DECONNECTER TOUS LES REGIMES EXTERNES. 2. PRESSER LE BOUTON D'ARRÊT. 3. PRESSER L'INTERRUPTEUR DE CONTROLÉUR A LA POSITION "OFF". 4. REMPLIR LE RESERVOIR A CARBURANT. 								
<p>OPERATOR'S MANUAL MUST BE STORED ON MACHINE. A REPLACEMENT OPERATOR'S MANUAL CAN BE ORDERED THROUGH WACKER NEUSON OR ONLINE AT WWW.WACKERNEUSON.COM.</p>	<p>EL MANUAL DE OPERACION DEBE SER RETENIDO EN LA MÁQUINA. CONTACTE A WACKER NEUSON PARA UN EJEMPLAR ADICIONAL O PONGA UNA ORDEN EN LINEA EN WWW.WACKERNEUSON.COM.</p>	<p>LA NOTICE D'EMPLOI DOIT ÊTRE MUNIE SUR LA MACHINE. CONTACTER WACKER NEUSON POUR COMMANDER UN EXEMPLAIRE SUPPLEMENTAIRE OU COMMANDER EN LIGNE CHEZ WWW.WACKERNEUSON.COM.</p>								
<p>M</p>		<p>Operator's Manual must be stored on machine. Replacement Operator's Manual can be ordered through your local Wacker Neuson distributor.</p>								
<p>N</p>	<div data-bbox="289 1627 808 1743" style="border: 1px solid black; padding: 5px;"> <p style="text-align: center;">WARNING</p> <p>Operation of This Equipment May Create Sparks That Can Start Fires Around Dry Vegetation. A Spark Arrestor May be Required. The Operator Should Contact Local Fire Agencies For Laws or Regulations Relating to Fire Prevention Requirements.</p> <p style="text-align: right; font-size: small;">Per CAL. PRC. CODE</p> </div>	<p>WARNING!</p> <p>Operation of this equipment may create sparks that can start fires around dry vegetation. A spark arrestor may be required. The operator should contact local fire agencies for laws or regulations relating to fire prevention requirements.</p>								

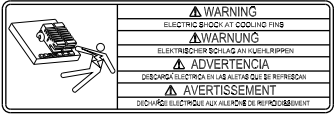
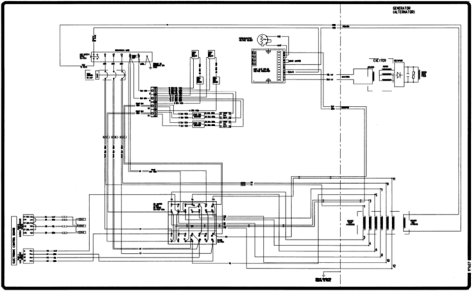
<p>P</p>		<p>Read and understand the supplied Operator's Manual before operating this machine. Failure to do so increases the risk of injury to yourself or others.</p>
<p>Q1</p>		<p>WARNING To reduce the risk of electrical shock and arc flash, read the Operator's Manual. Improper connection of the generator to a building's electrical system can allow electrical current from the generator to backfeed into utility lines. This may result in electrocution of utility workers, fire, or explosion. Connections to a building's electrical system must be made by a qualified electrician and comply with all applicable laws and electrical codes.</p>
<p>Q2</p>		<p>Voltage selector label</p>
<p>R</p>		<p>Remote start operation. Read Operator's Manual for instructions.</p>
<p>S</p>		<p>CAUTION Receptacles not to be used when: Selector switch set to 208/120V and voltage greater than 228V. Selector switch set to 480/277V and voltage greater than 457V.</p>

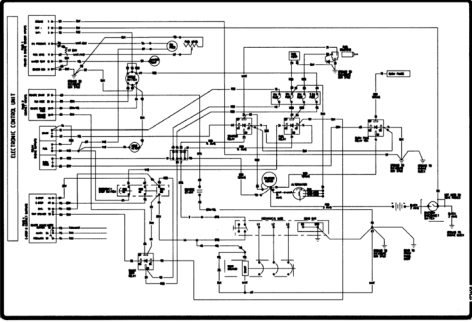
<p>T</p>	 <p>114891</p>	<p>WARNING Disconnect battery before servicing. Read the Operator's Manual.</p>								
<p>U</p>	<p>(on trailer, if equipped)</p> <table border="1" data-bbox="349 472 1226 598"> <thead> <tr> <th>TRAILER WIRING</th> <th>ANHÄNGER-VERDRÄHTUNG</th> <th>CANALIZACION ELECTRICA DE REMOLQUE</th> <th>DISPOSITION DES CABLES POUR REMORQUE</th> </tr> </thead> <tbody> <tr> <td>G - RIGHT BRAKE LIGHT AND DIRECTIONAL Y - LEFT BRAKE LIGHT AND DIRECTIONAL B_r - TAIL, SIDE AND LICENSE PLATE LIGHTS W - GROUND L - ELECTRIC BRAKES B - BATTERY CHARGE</td> <td>G - RECHTES BREMSLICHT UND BLINKER Y - LINKES BREMSLICHT UND BLINKER B_r - SCHLUSS-, SEITEN-UND KENNZEICHENLEUCHE W - ERDUNG L - ELEKTRISCHE BREMSE B - BATTERIE-LADUNG</td> <td>G - LUZ FRENO Y GIRO DERECHA Y - LUZ FRENO Y GIRO IZQUIERDA B_r - LUZ TRASERA, LATERAL Y PLACA DE MATRICULA W - TIERRA L - FRENS ELECTRICOS B - CARGA BATERIA</td> <td>G - FEUX DE STOP ET DE DIRECTION D Y - FEUX DE STOP ET DE DIRECTION G B_r - FEUX D'ARRIERE, DE POSITION ET DE PLAQUE D'IMMATRICULATION W - MISE A TERRE L - FREINS ELECTRIQUES B - CHARGE DE LA BATTERIE</td> </tr> </tbody> </table> <p>115681</p>	TRAILER WIRING	ANHÄNGER-VERDRÄHTUNG	CANALIZACION ELECTRICA DE REMOLQUE	DISPOSITION DES CABLES POUR REMORQUE	G - RIGHT BRAKE LIGHT AND DIRECTIONAL Y - LEFT BRAKE LIGHT AND DIRECTIONAL B _r - TAIL, SIDE AND LICENSE PLATE LIGHTS W - GROUND L - ELECTRIC BRAKES B - BATTERY CHARGE	G - RECHTES BREMSLICHT UND BLINKER Y - LINKES BREMSLICHT UND BLINKER B _r - SCHLUSS-, SEITEN-UND KENNZEICHENLEUCHE W - ERDUNG L - ELEKTRISCHE BREMSE B - BATTERIE-LADUNG	G - LUZ FRENO Y GIRO DERECHA Y - LUZ FRENO Y GIRO IZQUIERDA B _r - LUZ TRASERA, LATERAL Y PLACA DE MATRICULA W - TIERRA L - FRENS ELECTRICOS B - CARGA BATERIA	G - FEUX DE STOP ET DE DIRECTION D Y - FEUX DE STOP ET DE DIRECTION G B _r - FEUX D'ARRIERE, DE POSITION ET DE PLAQUE D'IMMATRICULATION W - MISE A TERRE L - FREINS ELECTRIQUES B - CHARGE DE LA BATTERIE	
TRAILER WIRING	ANHÄNGER-VERDRÄHTUNG	CANALIZACION ELECTRICA DE REMOLQUE	DISPOSITION DES CABLES POUR REMORQUE							
G - RIGHT BRAKE LIGHT AND DIRECTIONAL Y - LEFT BRAKE LIGHT AND DIRECTIONAL B _r - TAIL, SIDE AND LICENSE PLATE LIGHTS W - GROUND L - ELECTRIC BRAKES B - BATTERY CHARGE	G - RECHTES BREMSLICHT UND BLINKER Y - LINKES BREMSLICHT UND BLINKER B _r - SCHLUSS-, SEITEN-UND KENNZEICHENLEUCHE W - ERDUNG L - ELEKTRISCHE BREMSE B - BATTERIE-LADUNG	G - LUZ FRENO Y GIRO DERECHA Y - LUZ FRENO Y GIRO IZQUIERDA B _r - LUZ TRASERA, LATERAL Y PLACA DE MATRICULA W - TIERRA L - FRENS ELECTRICOS B - CARGA BATERIA	G - FEUX DE STOP ET DE DIRECTION D Y - FEUX DE STOP ET DE DIRECTION G B _r - FEUX D'ARRIERE, DE POSITION ET DE PLAQUE D'IMMATRICULATION W - MISE A TERRE L - FREINS ELECTRIQUES B - CHARGE DE LA BATTERIE							
<p>W</p>	 <p>0160604</p>	<p>Drain containment system (if equipped).</p>								
<p>X</p>	 <p>164721</p>	<p>WARNING To prevent hearing loss, wear hearing protection when operating the machine. WARNING Pressurized contents. Do not open when hot. WARNING Hand injury if entangled in moving belt. WARNING Rotating machinery! Do not reach inside machine when the engine is running.</p>								
<p>Y</p>	 <p>114893</p>	<p>Operating the main circuit breaker supplies or interrupts power to the customer connection lugs.</p>								

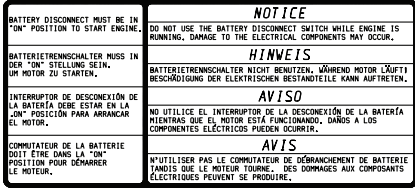
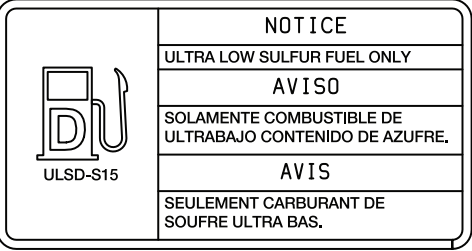
<p>Z</p>	 <p>NEUTRAL BONDED TO FRAME NULL-LEITER AM RAHMEN ANGESCHLOSSEN CONDUCTOR NEUTRO CONECTADO AL CHASIS CONDUCTEUR NEUTRE MIS A LA MASSE DU CHASSIS 116662</p>	<p>Neutral bonded to frame</p>
<p>AA</p>	 <p>FUSES SICHERUNGEN FUSIBLES FUSIBLES</p> <p></p> <p>1 2 3 4</p>	<p>Fuses Read the Operator's Manual for machine information.</p>
<p>BB</p>	 <p>WARNING ELECTRIC SHOCK AT COOLING FINS WARNUNG ELEKTRISCHER SCHLAG AN KÜHLER-RIPPEN ADVERTENCIA DESCARGA ELÉCTRICA EN LAS ALAS DEL REFRIGERADOR AVERTISSEMENT DÉCHARGE ÉLECTRIQUE AUX ALÈRES DE RÉFROIDISSEMENT</p>	<p>WARNING Electric shock at cooling fins.</p>
<p>CC</p>		<p>Generator and receptacle wiring</p>

<p>DD</p>		<p>Engine wiring</p>
<p>EE</p>		<p>WARNING Hot surface</p>
<p>FF</p>		<p>(if equipped)</p> <p>Battery disconnect must be in “ON” position to start engine.</p> <p>NOTICE Do not use the battery disconnect switch while engine is running. Damage to the electrical components may occur.</p>
<p>GG</p>		<p>Low sulfur fuel or ultra low sulfur fuel only.</p>
<p>JJ</p>		<p>Protecting Our Environment Fluid containment system</p>

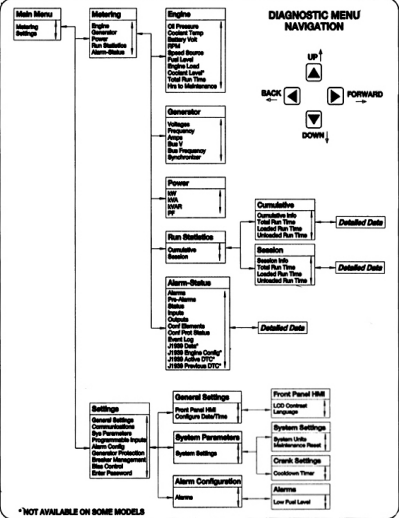
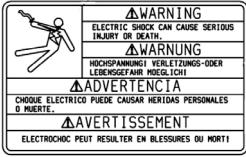
<p>KK</p>	 <p>*NOT AVAILABLE ON SOME MODELS</p>	<p>Diagnostic menu navigation</p>																
<p>MM</p>	<p>U.S. PAT. Nos.: OTHER U.S. AND FOREIGN PATENTS PENDING</p>	<p>This machine may be covered by one or more patents.</p>																
<p>NN</p>	<p>(on trailer, if equipped)</p> <table border="1" data-bbox="305 1035 776 1228"> <tr> <td colspan="2">MANUFACTURED BY/FABRIQUÉ PAR:</td> <td colspan="2">DATE OF MFG.:</td> </tr> <tr> <td>GVWR/PMBV</td> <td></td> <td colspan="2">COLD INFL. PRESS./PRESS. DE GONF À FROID</td> </tr> <tr> <td>GAWR/PMBE</td> <td>TIRE/PNEU - DIMENSION - RIM/JANTE</td> <td>KPA (PSI/LPC)</td> <td>SGI/DUAL</td> </tr> <tr> <td colspan="4"> <small>THIS VEHICLE CONFORMS TO ALL APPLICABLE STANDARDS PRESCRIBED UNDER THE CANADIAN MOTOR VEHICLE SAFETY REGULATIONS IN EFFECT ON THE DATE OF MANUFACTURE. / CE VÉHICULE EST CONFORME À TOUTES LES NORMES QUI LUI SONT APPLICABLES EN VERTU DU RÈGLEMENT SUR LA SÉCURITÉ DES VÉHICULES AUTOMOBILES DU CANADA EN VIGUEUR À LA DATE DE SA FABRICATION.</small> <small>THIS VEHICLE CONFORMS TO ALL APPLICABLE U.S. FEDERAL MOTOR VEHICLE SAFETY STANDARDS (FMVSS) IN EFFECT ON THE DATE OF MANUFACTURE SHOWN ABOVE.</small> <small>V.I.N./N.I.V.</small> <small>TYPE DE VÉHICULE/TYPE DE VÉHICULE :</small> </td> </tr> </table>	MANUFACTURED BY/FABRIQUÉ PAR:		DATE OF MFG.:		GVWR/PMBV		COLD INFL. PRESS./PRESS. DE GONF À FROID		GAWR/PMBE	TIRE/PNEU - DIMENSION - RIM/JANTE	KPA (PSI/LPC)	SGI/DUAL	<small>THIS VEHICLE CONFORMS TO ALL APPLICABLE STANDARDS PRESCRIBED UNDER THE CANADIAN MOTOR VEHICLE SAFETY REGULATIONS IN EFFECT ON THE DATE OF MANUFACTURE. / CE VÉHICULE EST CONFORME À TOUTES LES NORMES QUI LUI SONT APPLICABLES EN VERTU DU RÈGLEMENT SUR LA SÉCURITÉ DES VÉHICULES AUTOMOBILES DU CANADA EN VIGUEUR À LA DATE DE SA FABRICATION.</small> <small>THIS VEHICLE CONFORMS TO ALL APPLICABLE U.S. FEDERAL MOTOR VEHICLE SAFETY STANDARDS (FMVSS) IN EFFECT ON THE DATE OF MANUFACTURE SHOWN ABOVE.</small> <small>V.I.N./N.I.V.</small> <small>TYPE DE VÉHICULE/TYPE DE VÉHICULE :</small>				<p>(On trailer, if equipped)</p> <p>Certification Label (VIN Number) Also attached to each unit is a Certification Label. This label specifies that the trailer conforms with all Federal Motor Vehicle Standards in effect at the time of manufacture. The label includes the Vehicle Identification Number (VIN) for the trailer.</p>
MANUFACTURED BY/FABRIQUÉ PAR:		DATE OF MFG.:																
GVWR/PMBV		COLD INFL. PRESS./PRESS. DE GONF À FROID																
GAWR/PMBE	TIRE/PNEU - DIMENSION - RIM/JANTE	KPA (PSI/LPC)	SGI/DUAL															
<small>THIS VEHICLE CONFORMS TO ALL APPLICABLE STANDARDS PRESCRIBED UNDER THE CANADIAN MOTOR VEHICLE SAFETY REGULATIONS IN EFFECT ON THE DATE OF MANUFACTURE. / CE VÉHICULE EST CONFORME À TOUTES LES NORMES QUI LUI SONT APPLICABLES EN VERTU DU RÈGLEMENT SUR LA SÉCURITÉ DES VÉHICULES AUTOMOBILES DU CANADA EN VIGUEUR À LA DATE DE SA FABRICATION.</small> <small>THIS VEHICLE CONFORMS TO ALL APPLICABLE U.S. FEDERAL MOTOR VEHICLE SAFETY STANDARDS (FMVSS) IN EFFECT ON THE DATE OF MANUFACTURE SHOWN ABOVE.</small> <small>V.I.N./N.I.V.</small> <small>TYPE DE VÉHICULE/TYPE DE VÉHICULE :</small>																		
<p>QQ</p>	<p>Lug door must be closed for lugs and receptacles to energize. La puerta de conexiones debe estar cerrada para que las conexiones y los tomacorrientes actúen. La porte de cosses terminales doit être fermée pour que les cosses terminales et les prises de courant puissent amorcer.</p>	<p>(Camlock models only)</p> <p>Lug door must be closed for lugs and receptacles to energize.</p>																
<p>RR</p>		<p>(Camlock models only)</p> <p>WARNING Electric shock can cause serious injury or death.</p>																
<p>SS</p>	<p>NOTICE Separate overcurrent protection must be provided. Do not exceed 400 amps per receptacle. AVISO Protección adicional contra sobrecorriente debe ser suministrada. No exceder los 400 amperios por tomacorrientes. AVIS Protection supplémentaire contre surintensité doit être fournie. Ne pas dépasser 400 ampères par prise de courant. 5200000525</p>	<p>(Camlock models only)</p> <p>NOTICE Separate overcurrent protection must be provided. Do not exceed 400 amps per receptacle.</p>																

<p>TT</p>		<p>(Camlock models only)</p> <p>WARNING Electric shock and arc flash can cause serious injury or death.</p>
<p>UU</p>		<p>WARNING Explosion hazard.</p> <ul style="list-style-type: none"> Do not use evaporative starting fluids such as ether on this engine. The engine is equipped with a cold starting aid. Using evaporative starting fluids can cause an explosion which can cause engine damage, personal injury, or death. Read and follow the engine starting instructions in this Operator's Manual.
<p>VV</p>		<p>WARNING</p> <ul style="list-style-type: none"> Keep all sparks and open flames away from the battery. Wear eye protection. Keep away from children. Battery acid is poisonous and corrosive. Read the Operator's Manual. Explosion hazard. <p>Dispose of waste batteries in accordance with local environmental regulations. Battery contains mercury (Hg), cadmium (Cd), or lead (Pb).</p>
<p>WW</p>		<p>WARNING Operation of this equipment may create sparks that can start fires around dry vegetation. A spark arrester may be required. The operator should contact local fire agencies for laws or regulations relating to fire prevention requirements.</p>
<p>XX</p>		<p>California Proposition 65 Warning Cancer and Reproductive Harm - www.P65Warnings.ca.gov.</p>
<p>YY</p>		<p>Recommended position before starting engine</p>

4 Lifting and Transporting

4.1 Lifting the Machine

- Requirements**
- Lifting equipment (crane, hoist, or fork truck) capable of supporting the machine's weight
 - Lifting devices (hooks, chains, and shackles) capable of supporting the machine's weight
 - Engine stopped

Lifting the machine

A lifting eye is used for lifting the machine.

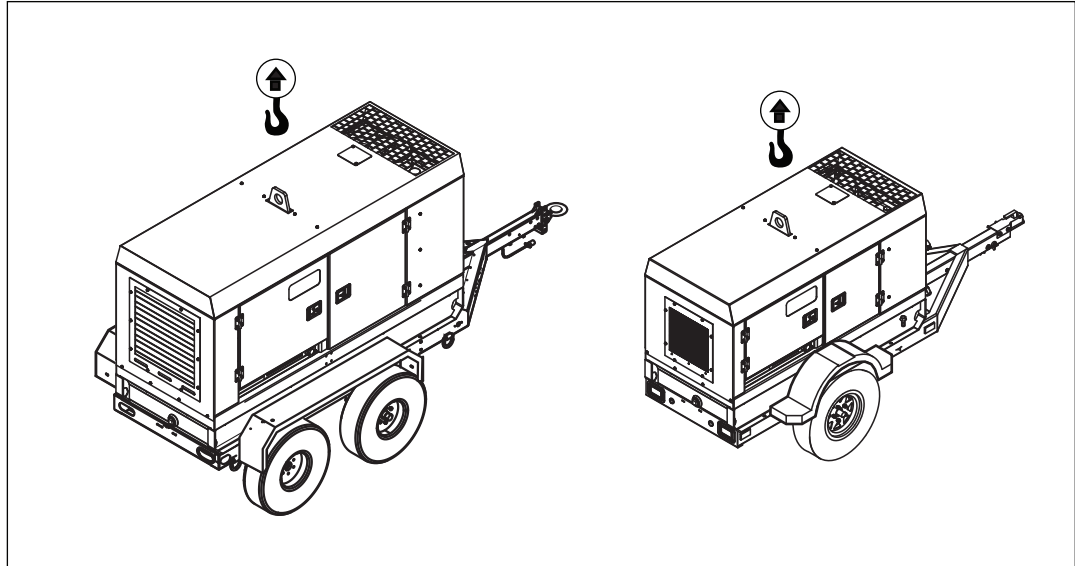

wc_gr011429

Perform the procedure below to lift the machine.

1. Attach the lifting devices and equipment to the lifting eye. Do not attach lifting devices to any other part of the machine.
2. Lift the machine a small distance.



WARNING

Crushing hazard. An unstable machine may cause the lifting devices and equipment to fail. You may be crushed if the lifting devices and equipment fail.

- ▶ Check for stability before continuing.

3. Check for stability. If necessary, lower the machine, reposition the lifting devices, and lift the machine a small distance again.
4. Continue lifting the machine only when it is stable.

4.2 Before Towing Checklist

Before towing the machine, check the licensing requirements for trailers in your area. Also check the following items:

Towing vehicle

- Check that the towing vehicle is rated to tow the load.
- Check that the towing vehicle is in serviceable condition.
- Do any necessary service/maintenance on the towing vehicle.

Hitch and coupler

- Check that the towing vehicle and hitch have a rating equal to or greater than the GVWR of the machine. See chapter *Technical Data*.
- Check that the hitch of the towing vehicle and coupler of the trailer are compatible.
- Check the condition of both the coupler and the hitch.
- Check that all fasteners on the coupler are tight.
- Check that the coupler has fresh grease applied to it.

Wheels

- Check that wheel chocks are available at the work site.
- Check that all lug nuts are in place and are properly torqued.
- Check the tread wear of the tires.
- Check that the tires are inflated to the proper pressure.

Trailer preparation

- Check that all doors and access panels are closed and latched.
- Check that outriggers (if applicable) are retracted.
- Check local regulations regarding hazardous materials placards. If applicable, install the appropriate placards.

Trailer operation

- Check that the trailer jacks are in the traveling (horizontal) position.
- Check that the directional and running lights on the trailer function correctly.
- Check that the safety chains of the trailer are connected to the towing vehicle using a crisscross pattern.
- Check the operation of the trailer brakes by braking the towing vehicle at a slow speed. Both the vehicle and the trailer must brake smoothly. If the trailer pushes, check the fluid level in the surge brakes or the operation of the electric brakes.
- Check that the trailer's breakaway cable (if applicable) is attached to the towing vehicle.
- Test the function of the breakaway system (if applicable).

4.3 Towing the Machine

Background The generator's trailer is equipped with brakes (surge or electric), safety chains (a), lights, and a coupler (pintle or ball-type) (b).

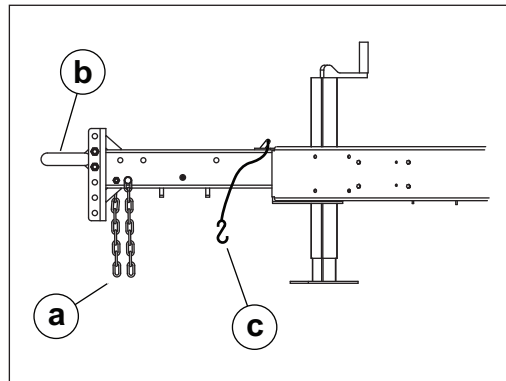

wc_gr011430

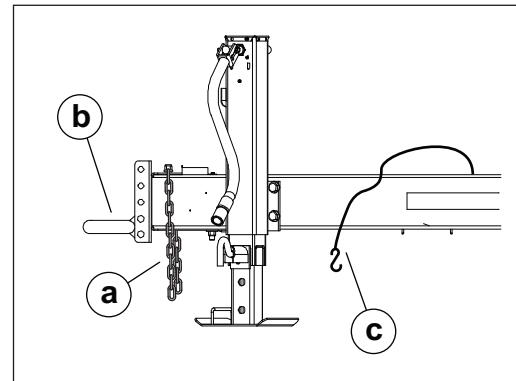

wc_gr012751

Brakes Only use the brakes as designed.

- The breakaway cable (c) is not a parking brake and should not be used as one.

Licensing requirements

- In most states, large trailers must be registered and licensed by the State Department of Transportation. Before towing, be sure to check licensing requirements.
- Drivers towing trailers may be required to carry a commercial driver's license (CDL). Check your local and state licensing regulations before towing the generator.

Coupler maintenance

- A film of grease on the coupler will extend coupler life and eliminate squeaking. Wipe the coupler clean and apply fresh grease each time the trailer is towed.

Towing safety

- When towing, maintain extra space between vehicles and avoid soft shoulders, curbs, and sudden lane changes. If you have not pulled a trailer before, practice turning, stopping, and backing up in an area away from heavy traffic.
- Do not exceed 55 mph when towing a trailer.

4.4 Preparing the Machine for Transport on a Truck or Trailer

- Requirements**
- Machine stopped
 - Flatbed truck or trailer capable of supporting the machine's weight
 - Chains, hooks, or straps capable of supporting the machine's weight



WARNING

Crushing hazard. Improperly securing the machine can lead to a crushing hazard.

- ▶ Use only the designated tie-down points to secure the machine to a truck or trailer.
-

Checklist

Before transporting the machine, check the following items:

Machine

- Check that all accessories are securely stored within the machine.
- Check that all doors and access panels of the machine are closed.
- Check that all electrical supplies are disconnected from the machine.
- For machines with external fuel supplies, check that all fuel supplies are disconnected from the machine.
- For machines with generators, check that the generator is shut down.

Loading and transporting equipment

- Check that the transport vehicle or trailer can support the weight of the machine.
- Check that the transport vehicle or trailer is wide enough to support the machine.
- Check that the wheels of the transport vehicle or trailer are chocked during the loading process.
- Check that the transport vehicle or trailer is clean and free of grease, oil, ice, and other loose material.
- If the machine is mounted to a trailer, check that the jackstand or other transport block (piece of wood or other similar material) is available to support the trailer tongue during transporting. Do not use the machine's trailer jack to support the trailer tongue during transporting.
- Check that any ramps used in the loading process:
 - Can support the weight of the machine.
 - Are clean and free of grease, oil, ice, and other loose material.
 - Are securely connected to the transport vehicle or trailer.
 - Are of sufficient length to keep the loading angle 15° or less.

In addition:

- Check that the loading area is flat and the ground is stable.
- Check the overall height of the machine once it is loaded on the truck or trailer.
- Plan your travel route so there will be adequate clearance for overpasses, road signs, buildings, etc.
- Check local regulations regarding transporting and obey these regulations.

4.5 Hazardous Materials Placards

Overview

Hazardous materials placards may have been provided with your machine. Transport Canada, and the Canadian Transportation of Dangerous Goods Act, require that these hazardous materials placards be permanently applied to certain machines if they are to be transported or towed on Canadian roads.

Contact Transport Canada if you have questions about driver's licensing requirements for transporting machines that bear hazardous materials placard, or questions about other restrictions for use of this machine

Note: *The owner/operator of this machine is responsible for applying the placards. Use the procedure described below.*



wc_gr009231

Requirements

- Placard mounting surfaces and surrounding ambient temperature should be at least 10°C (50°F). In colder conditions, see application step 2 below.
- Mild soap or detergent
- Fresh, clean, warm water supply
- Isopropyl (rubbing) alcohol, lacquer thinner, or mineral spirits
- Soft, clean, dry cloths
- Plastic squeegee or stiff cardboard

Apply the placards

Four placards have been provided with this machine—one for each side, one for the front, and one for the back.

To apply the placards, do the following:

1. Clean the placard mounting surfaces with mild soap and water. Dry thoroughly.
2. Use isopropyl (rubbing) alcohol to clean the placard mounting surfaces if:
 - they, and the surrounding ambient temperature, are below 10°C (50°F)
 - the placard mounting surfaces are covered with grease and oil.
3. Peel about 2 cm (1 in.) of backing paper from the top of the placard. Fold the backing paper away from the placard.
4. Apply the top of the placard to the mounting surface.
 - a. Gradually remove the backing paper and apply the remainder of the placard.
 - b. Firmly press and smooth the placard into place with a plastic squeegee, stiff cardboard, or a soft cloth.
 - c. Puncture any air bubbles that may form.

4.6 Testing the Breakaway System—Hydraulic Surge Brakes

- Requirements**
- Hydraulic reservoir filled
 - Machine parked on a flat surface

- When**
- Before towing
 - After filling the hydraulic reservoir

Procedure Perform the procedure below to test the breakaway system.

1. Position the machine/trailer on a flat surface.
2. Connect the breakaway cable (a) to the tow vehicle. Do not connect the machine/trailer to the tow vehicle via the hitch.

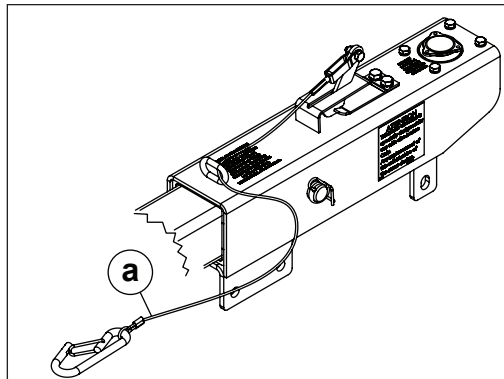

wc_gr008509

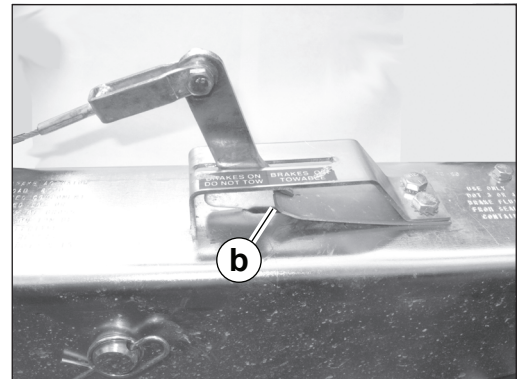

wc_gr008508

3. Slowly move the tow vehicle so that it pulls on the breakaway cord until the emergency lever reaches its second notch (b) and locks into the ON position.
4. Connect the machine/trailer to the tow vehicle via the hitch.
5. Attempt to tow the machine/trailer at a very slow speed (less than 5 mph). When activated, a properly working breakaway system will cause substantial drag on the trailer wheels and may even cause the trailer wheels to lock.



WARNING

Personal injury hazard. A faulty breakaway system may lead to an accident and personal injury if the machine/trailer breaks away.

- ▶ Do not tow the machine/trailer if the breakaway system is faulty.

6. If the brakes did not function, repair any faults before towing.
7. Stop the tow vehicle.
8. Release the brake by simultaneously pulling on the breakaway cord and prying the locking spring with a screwdriver (c) or pry bar.

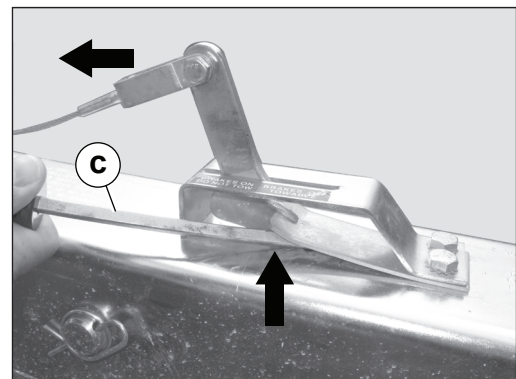

wc_gr008510

4.7 Testing the Breakaway System—Electric Brakes

- Requirements**
- Voltmeter
 - Battery charger or backup battery (charged)

- When**
- Before towing
 - Monthly if the machine is not in service

Procedure Perform the procedure below to test the breakaway system.

NOTICE: Disconnect the trailer wiring plug from the tow vehicle before testing. Failure to do so will result in severe damage to the electronic brake control.

1. Connect the machine/trailer to the tow vehicle.
2. Disconnect the trailer wiring plug **(a)** from the tow vehicle.

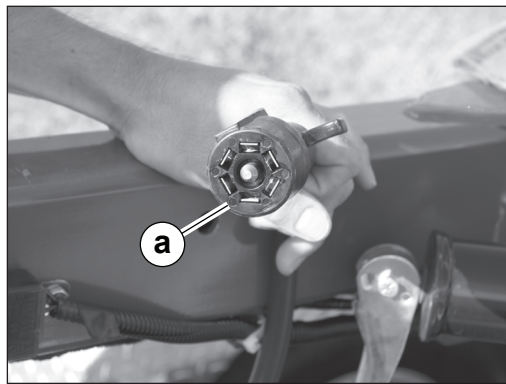

wc_gr008513

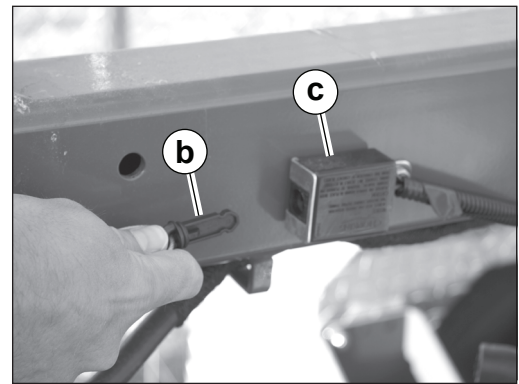

wc_gr008514

3. Pull the breakaway pin **(b)** out of the brake switch **(c)** (to activate the brakes) and attempt to tow the machine/trailer at a very slow speed (less than 5 mph). When activated, a properly working breakaway system will cause substantial drag on the trailer wheels and may even cause the trailer wheels to lock.
4. Stop the tow vehicle.



WARNING

Personal injury hazard. A faulty breakaway system may lead to an accident and personal injury if the machine/trailer breaks away.

- ▶ Do not tow the machine/trailer if the breakaway system is faulty.

This procedure continues on the next page.

Continued from the previous page.

5. If the brakes did not function, check the voltage of the breakaway battery.
To do so:
 - a. Remove the cover of the battery box.
 - b. Remove the wires connected to the breakaway battery **(d)**.
 - c. Measure the voltage. If 12–14 VDC is not measured, replace or recharge the breakaway battery.

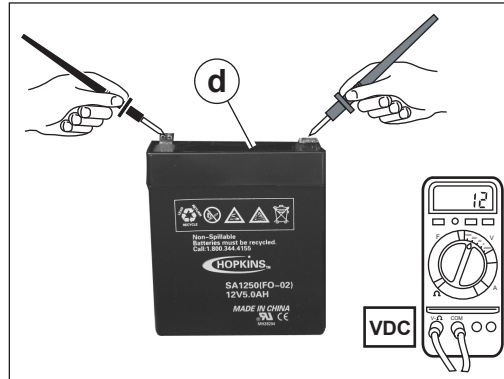

wc_gr008515

6. If 12–14 VDC was measured but the brakes did not function, there is a wiring or mechanical fault with the brakes. Repair any faults before towing.
7. If the brakes function properly:
 - a. Reconnect the wires to the breakaway battery.
 - b. Reinstall the cover to the battery box.
 - c. Reinstall the breakaway pin **(b)** into the brake switch.
 - d. Connect the trailer wiring plug to the tow vehicle.

5 Machine Setup

5.1 Preparing the Machine for First Use

1. Make sure all loose packaging materials have been removed from the machine.
2. Check the machine and its components for damage. If there is visible damage, do not operate the machine. Contact your Wacker Neuson dealer immediately for assistance.
3. Take inventory of all items included with the machine and verify that all loose components and fasteners are accounted for.
4. Add fluids as needed and applicable, including fuel, engine oil, hydraulic oil, retardant, and battery acid.
5. Move the machine to its operating location.
6. Connect component parts not already attached.

Safety information

- Do not exceed the power output of the generator. Damage to tools or generator will occur. Refer to chapter *Technical Data*.
- When using the generator as a standby or substitute power supply, make sure the voltage and phase rotation of the line connections match those of the utility lines. Failure to match phase rotation and voltage may cause equipment connected to the generator to operate incorrectly. This could create unsafe operating conditions.
- Do not exceed the rated current limit of any receptacle.
- The bonding bar between the ground connections must remain in place at all times unless a qualified electrician determines otherwise.

CO alarms

Because this machine produces carbon monoxide (CO), Wacker Neuson recommends that CO alarms be installed in all structures in close proximity to the machine. CO alarms provide an extra measure of protection against this poison that you cannot see or smell.

Install battery-operated CO alarms or plug-in CO alarms with battery backup, according to the manufacturer's instructions. CO alarms should be certified to the requirements of the latest safety standards (UL 2034, IAS 6-96, or CSA 6.19.01). Test the CO alarm batteries monthly.

5.2 Positioning the Machine

**WARNING**

Fire hazard. Do not move the machine while it is running.

- ▶ Shut down the machine before moving or repositioning it.

**WARNING**

Fire hazard. Machines positioned on a hill or an incline may slide, break away or roll over.

- ▶ Do not position the machine on a hill or an incline.

**WARNING**

Explosion and fire hazard. Risk of severe injury or death.

- ▶ Do not operate the machine near flammable vapors, fuels, or combustibles.

CO alarms

Because this machine produces carbon monoxide (CO), Wacker Neuson recommends that CO alarms be installed in all structures in close proximity to the machine. CO alarms provide an extra measure of protection against this poison that you cannot see or smell.

Install battery-operated CO alarms or plug-in CO alarms with battery backup, according to the manufacturer's instructions. CO alarms should be certified to the requirements of the latest safety standards (UL 2034, IAS 6-96, or CSA 6.19.01). Test the CO alarm batteries monthly.

Requirements

Position the machine so that:

- Engine exhaust will not enter nearby structures.
- The machine does not block traffic.
- The machine is not close to any combustible material or flammable vapor.
- All of the machine's access doors/panels may be accessed.
- The area overhead is clear of debris that could fall onto or into the machine or exhaust compartment.
- The machine is on a firm, level surface and will not tip, roll, slide, or fall while operating.

This procedure continues on the next page.

Continued from the previous page.

Procedure

Perform the procedure below to position the machine.

1. Place the machine on solid, stable, and level ground.
2. For machines with trailers, install chocks (a) under the wheels.

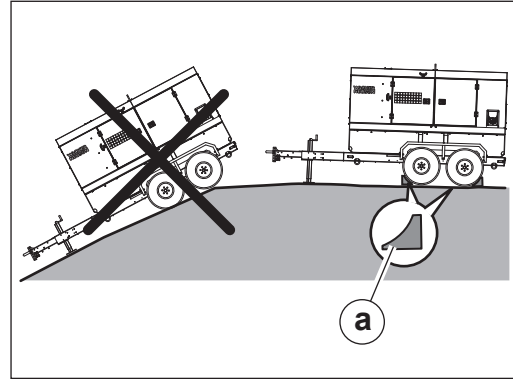

wc_gr009186

5.3 Grounding the Generator

External grounding

A ground connection is located at the customer connection terminal lugs.

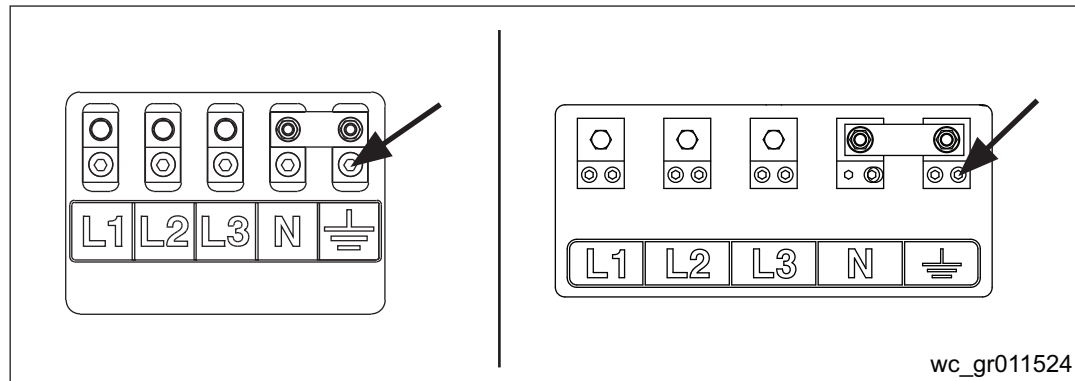

wc_gr011524

This ground connection is used for electrically grounding the generator when necessary to comply with the National Electrical Code and other federal, state, and local regulations. For grounding requirements in your area, consult with a qualified electrician, electrical inspector, or local agency having jurisdiction over electrical compliance.

- If the generator is used at a construction site, there may be additional regulations that must be observed.
- In some areas, generators are required to be registered with local utility companies.

Internal grounding

- The exposed, conductive, noncurrent-carrying components that could become energized (e.g., fuel tank, engine, generator housing, control panel, enclosure, and trailer) are bonded (connected) to the machine's frame.
- The grounding wires of the machine's power outputs (receptacles, lugs, and camlocks) are bonded (connected) to the machine's frame.
- The neutral of the generator stator winding is bonded (connected) to the machine's frame.

5.4 Recommended Fuel

Low temperatures cause diesel fuel to gel. Always use the proper fuel for the conditions. Follow the guidelines in the table below.

Lowest expected ambient temperature	Recommended fuel ¹
Above freezing > 0°C (32°F)	#2 diesel plus additives
Below freezing < 0°C (32°F)	Winter-blend diesel

¹Your engine may require ultra low sulfur fuel. Consult the engine owner's manual.

NOTICE: Consult the engine owner's manual regarding the use of biodiesel fuel in this machine. Some biodiesel blends may clog the fuel system or gel at cold ambient temperatures sooner than petroleum-based diesel.



CAUTION

Fire hazard.

- ▶ Do not use gasoline, crankcase oil, or any oil containing gasoline.

5.5 Refueling the Machine—Basler Controller

- Requirements**
- Machine shut down
 - Engine cool
 - Machine/fuel tank level with the ground
 - Remote switch disconnected from the remote run terminal
 - Fresh, clean fuel supply

Procedure Perform the procedure below to refuel the machine.



WARNING

Fire hazard. Fuel and its vapors are extremely flammable. Burning fuel can cause severe burns.

- ▶ Keep all sources of ignition away from the machine while refueling.
- ▶ Refuel only when the machine is outdoors.
- ▶ Clean up spilled fuel immediately.

1. Remove the fuel cap.
2. Place the engine start switch **(a)** in the REMOTE START position.

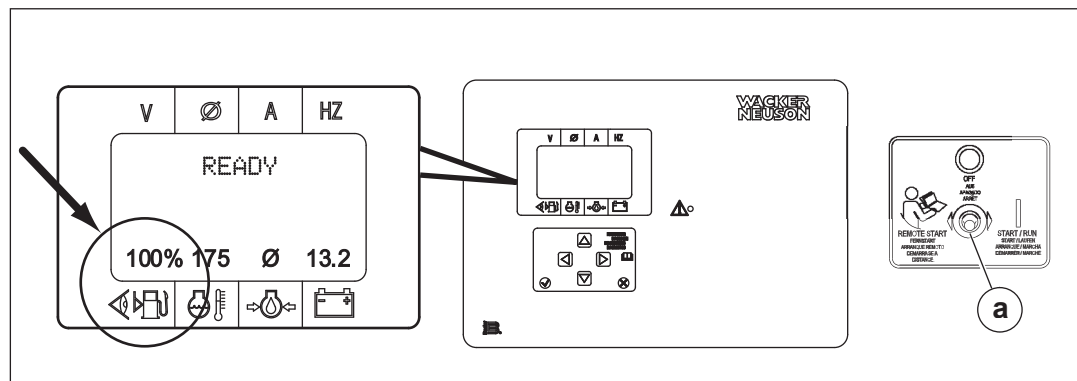

wc_gr008413

3. The fuel level (in percentage of the fuel tank capacity) will be displayed in the lower left corner of the LCD screen.
4. Fill the fuel tank until the fuel level reaches 100%.



CAUTION

Fire and health hazard. Fuel expands when heated. Expanding fuel in an over-filled tank can lead to spills and leaks.

- ▶ Do not overfill the fuel tank.

5. Reinstall the fuel cap.
6. Place the engine start switch in the OFF position.

5.6 Refueling the Machine—Deep Sea Controller

- Requirements**
- Engine stopped
 - Machine/fuel tank level with the ground
 - Remote switch disconnected from the remote run terminal
 - Fresh, clean fuel supply

Procedure Perform the procedure below to refuel the machine.



WARNING

Fire hazard. Fuel and its vapors are extremely flammable. Burning fuel can cause severe burns.

- ▶ Keep all sources of ignition away from the machine while refueling.
- ▶ Refuel only when the machine is outdoors.
- ▶ Clean up spilled fuel immediately.

1. Remove the fuel cap.
2. Place the generator controller power switch in the ON position and wait for the Deep Sea controller to boot up.
3. Press the right arrow button to navigate to the “Engine” screen.

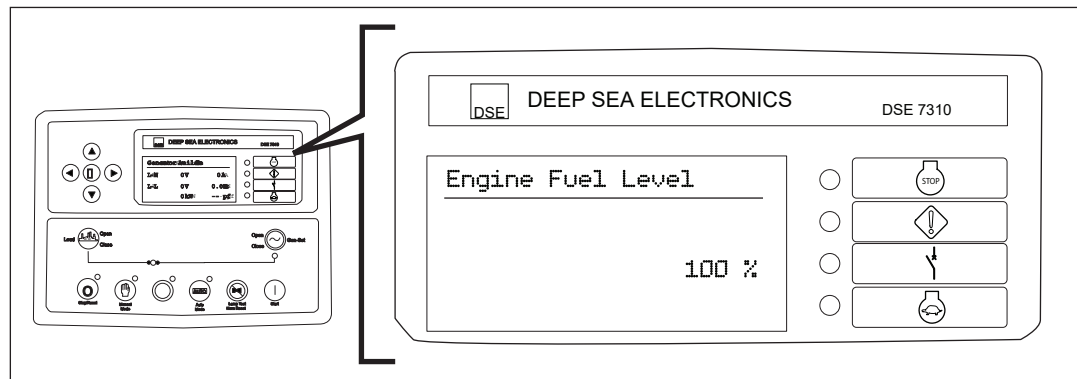

wc_gr011443

4. Use the up or down arrow button to navigate to the “Engine Fuel Level” screen. The fuel level (in percentage of the fuel tank capacity) will be displayed.

Note: The “Engine Fuel Level” screen will revert back to status screen after three minutes of inactivity.

5. Fill the fuel tank until the fuel level reaches 100%.



CAUTION

Fire and health hazard. Fuel expands when heated. Expanding fuel in an over-filled tank can lead to spills and leaks.

- ▶ Do not overfill the fuel tank.

6. Reinstall the fuel cap.
7. Place the generator controller power switch in the OFF position.

Operation, Control, and Component Locations

6 Operation, Control, and Component Locations

6.1 Control and Component Locations

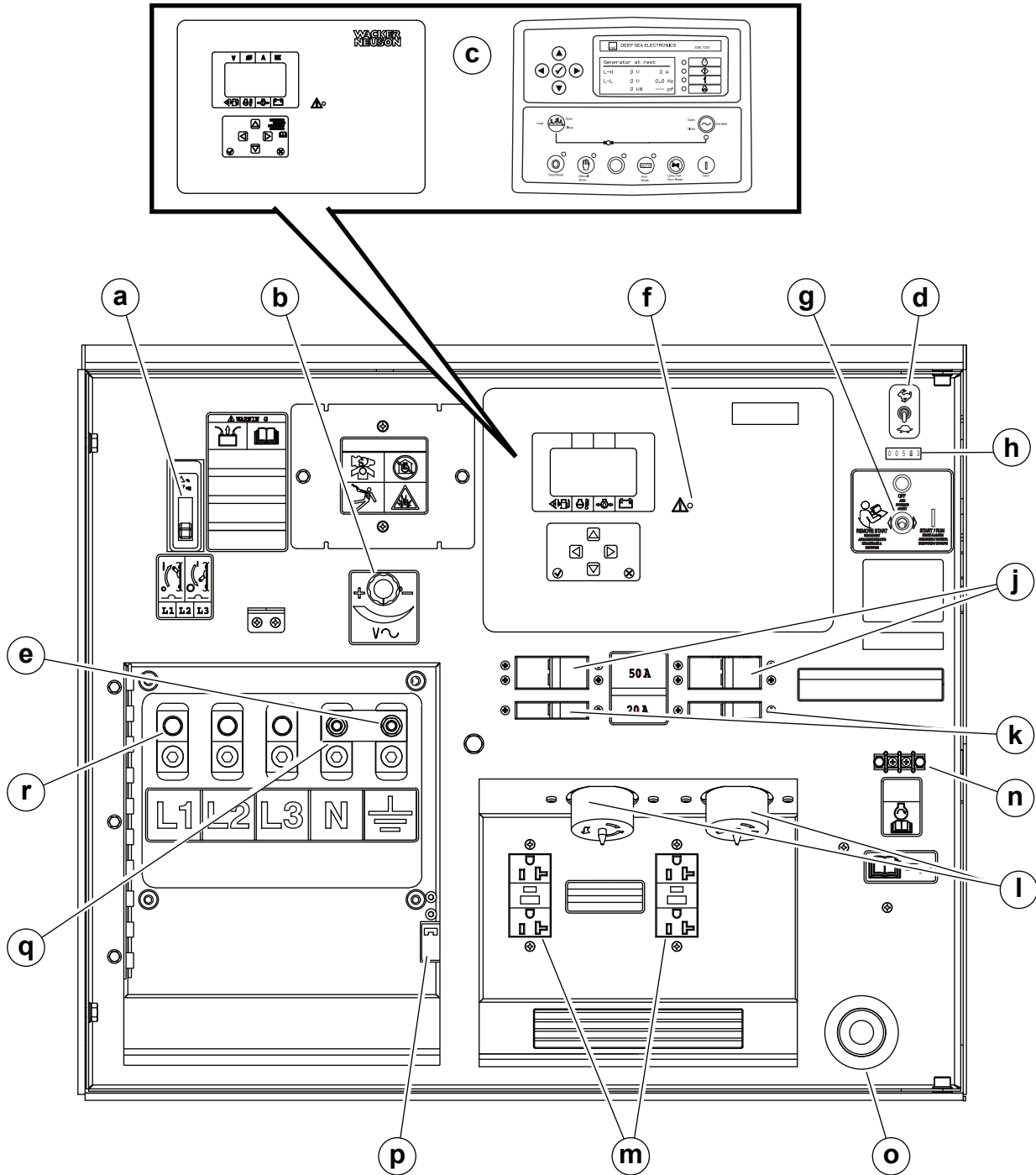

wc_gr011689

Operation, Control, and Component Locations

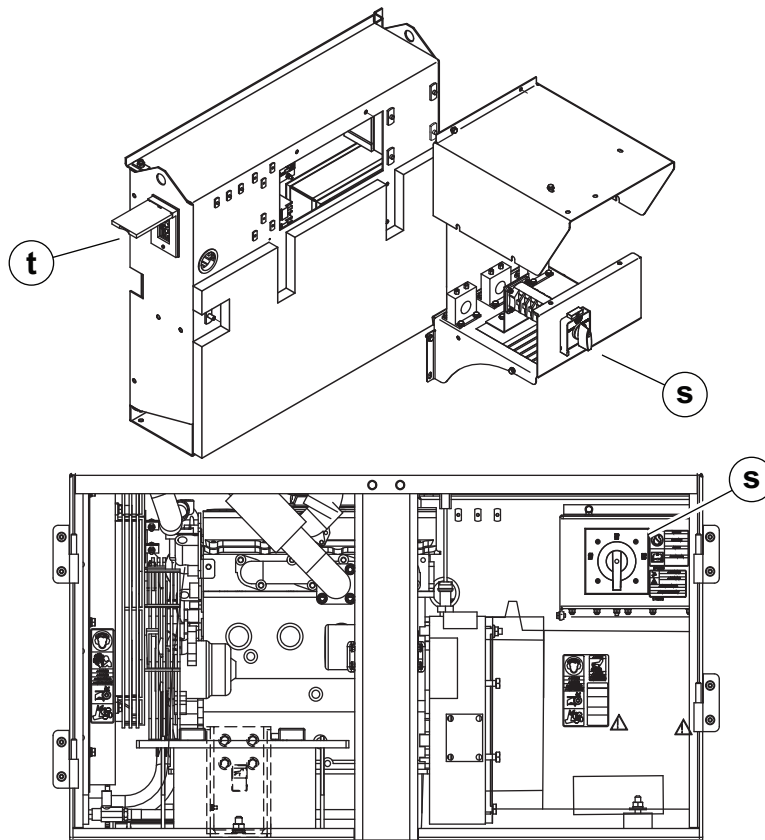

wc_gr011690

Ref.	Description	Ref.	Description
a	Main circuit breaker	l	Twist-lock receptacle (2) 240 VAC, 50A optional: (2) 240 VAC 20A, (1) 240 VAC 50A
b	Voltage adjustment rheostat	m	GFCI receptacle (120 VAC, 20A)
c	Generator controller	n	Remote run terminal block
d	Idle switch (high and low) (if equipped)	o	Emergency stop switch
e	Ground connection point	p	Lug door interlock switch
f	Pre-alarm/shutdown LED	q	Bond bar
g	Engine start switch	r	Terminal lugs
h	Hour meter	s	Voltage selector switch
j	Circuit breaker (240V, 20A or 50A)	t	Fuse box
k	Circuit breaker (120V, 20A)	u	Manual conditioning switch for aftertreatment exhaust system

7 Operation—Basler Controller

7.1 Main Circuit Breaker

Location Various styles of main circuit breakers may be found on Wacker Neuson Mobile generators. The main circuit breaker (**a**) is located on the control panel.

Note: *Graphic is representative only. Your machine may vary.*

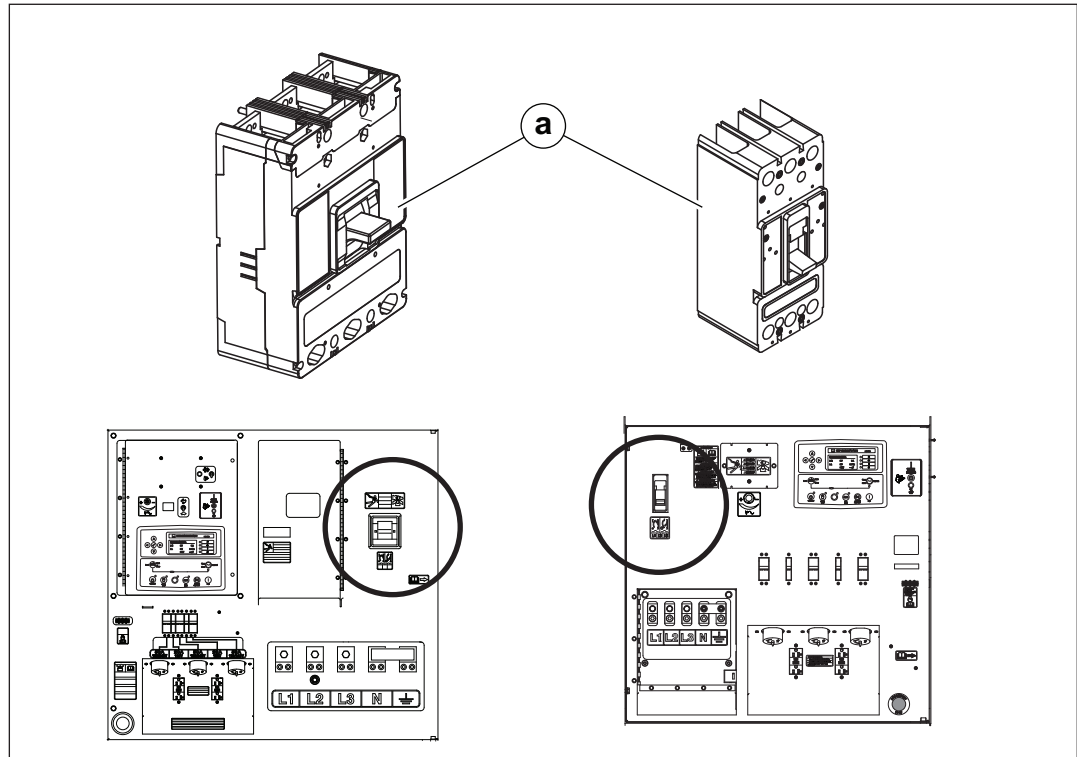

wc_gr011444

Functions

- The main circuit breaker interrupts power from the voltage selector switch to the terminal lugs.
- The main circuit breaker **does not** interrupt power to the convenience receptacles.



WARNING

Electric shock hazard. High voltage is present inside the control panel while the engine is running.

- ▶ Do not open the control panel unless the engine is stopped.

NOTICE: Before shutting down the generator or performing any service to the generator, make sure the main circuit breaker is in the OFF position.

7.2 Engine Start Switch

Description The engine start switch (a) is a three-position switch: “REMOTE START”, “OFF”, and “START/RUN”.

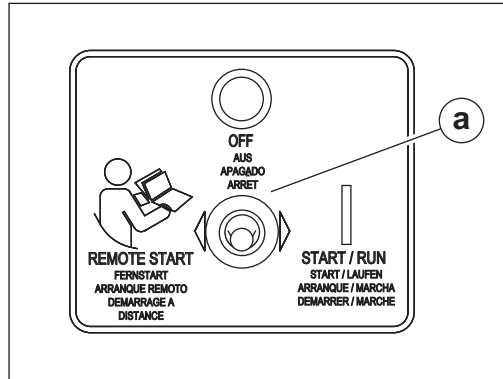

wc_gr011436

Function

Position	Function	LCD Screen
REMOTE START	This position is used when the generator is being operated as a stand-by power supply, and it is connected to a remote switch. The generator is in stand-by mode and will not start until the remote switch is activated (closed).	READY screen
START/RUN	This is the normal start and run position. When set to this position, power is supplied to the generator controller which immediately launches the start-up sequence. As a precaution, be prepared for engine startup anytime the engine start switch is in the REMOTE START position.	Monitoring screen
OFF	Power to the generator controller is disconnected.	Blank screen (off)

READY SCREEN

This screen is displayed when the start switch is in REMOTE START.

MONITORING SCREEN

This screen is displayed when the start switch is in START/RUN.

wc_gr010177

7.3 Generator Pre-Alarms and Alarms (Shut-Down Conditions)

Background The generator controller monitors variables of engine and machine function. The generator controller is programmed to signal pre-alarm conditions, and to shut down the machine when an alarm condition exists.

- Pre-alarms** Pre-alarm conditions are:
- Low fuel level
 - High coolant temperature
 - Low oil pressure
 - Time to maintenance

During a pre-alarm condition, the LCD panel (a) displays the type of pre-alarm, and the LED (b) flashes. The machine is not shut down.

- Alarms/ shutdowns** Shut-down conditions are:
- Low fuel level
 - High coolant temperature
 - Low oil pressure
 - Overspeed/Underspeed
 - Overcrank
 - Low coolant level (if equipped)
 - Overcurrent
 - Low oil level (option)¹

¹ Not used with Isuzu engine.

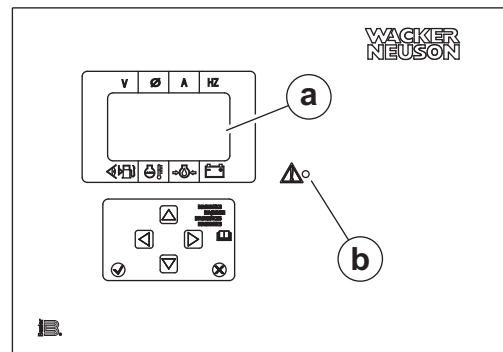

wc_gr011837

During an alarm condition, the LCD panel (a) displays the type of alarm, the LED (b) illuminates continuously, and the machine is shut down.

Variable	Normal	Pre-Alarm	Alarm	To Reset
Fuel level	>15%	15%	5%	Fill fuel tank. Toggle start switch.
Coolant temp	85°C±8	105°C	115°C	Add coolant. Toggle start switch.
Oil pressure	60–80 psi	20 psi	15 psi	Add engine oil. Toggle start switch.
Overspeed	60 Hz	—	66 Hz	Toggle start switch.
Underspeed	60 Hz	—	54 Hz	Toggle start switch.
Overcrank	—	—	After 3 attempts	Toggle start switch.
Time to maintain	250 hours	0 hours	—	Reset generator controller.
Coolant level	Above sender	—	Below sender	Add coolant. Toggle start switch.

7.4 Overcurrent Condition

Along with engine functions, the generator controller continuously monitors the current load in each leg. The values for current overload are programmed into the ECM at the factory and are different for each generator size.

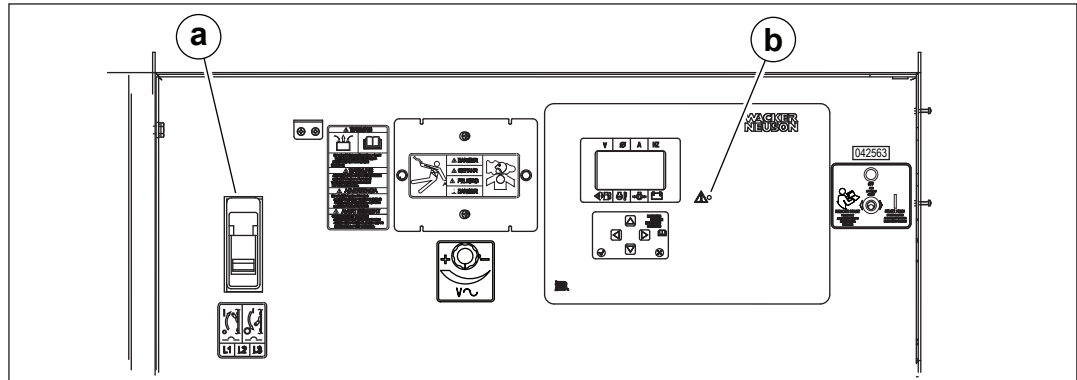

wc_gr010360

When an overcurrent condition is sensed in any leg, the pre-alarm/shutdown LED **(b)** flashes and the LCD displays OVERCURRENT.

If the overcurrent condition persists, the main circuit breaker **(a)** opens and the LCD screen changes to OVRLOAD - SET BRKR. This indicates an overload fault.

To clear the overload fault, reset the main circuit breaker. Failing to reset the main circuit breaker within 5 minutes will cause the machine to shut down. The LCD screen will then change to OVERLOAD.

7.5 Function of the Crankcase Pressure Switch (if equipped)

Function The crankcase pressure switch is a normally closed (NC) switch. Its purpose is to keep the engine from damage due to high pressure build-up inside the crankcase. If the vent hose becomes clogged because of ice forming inside of it, pressure builds within the crankcase. This pressure could damage the engine. The crankcase pressure switch prevents damage to the engine by shutting down the engine in the event of high pressure.

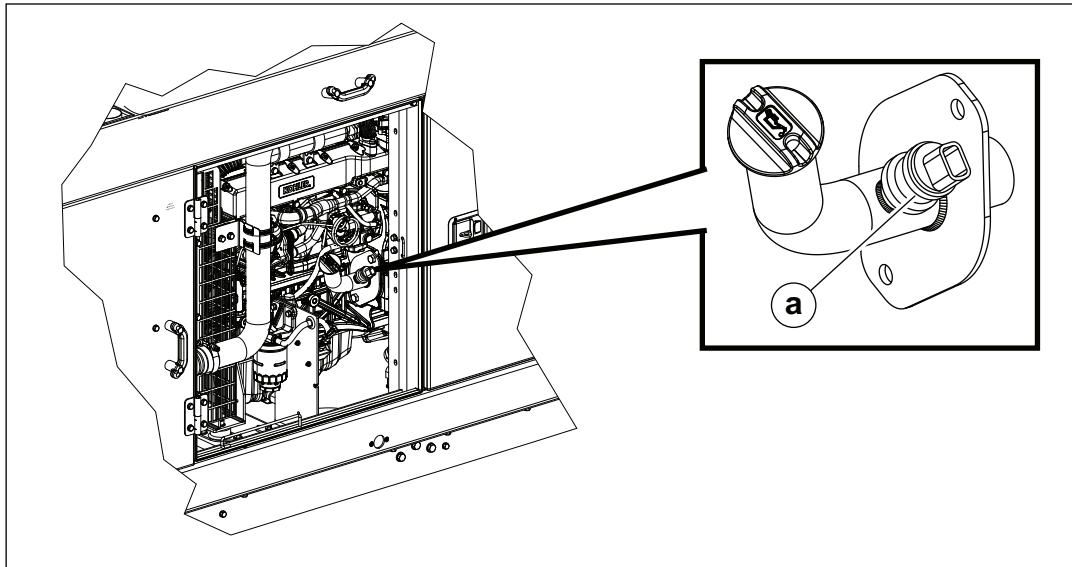

wc_gr015060

Operation When the crankcase pressure switch (a) senses high pressure (>5 psi):

- the crankcase pressure switch opens which informs the controller a high pressure condition exists
- the controller sends a shut down message to the engine
- the machine shuts down
- the message “Crankcase Pressure High” appears on the controller’s LCD display

This procedure continues on the next page.

Continued from the previous page.

Procedure

To rectify the condition, clear the vent hose of all obstructions.

1. Remove the insulation that covers the hose.

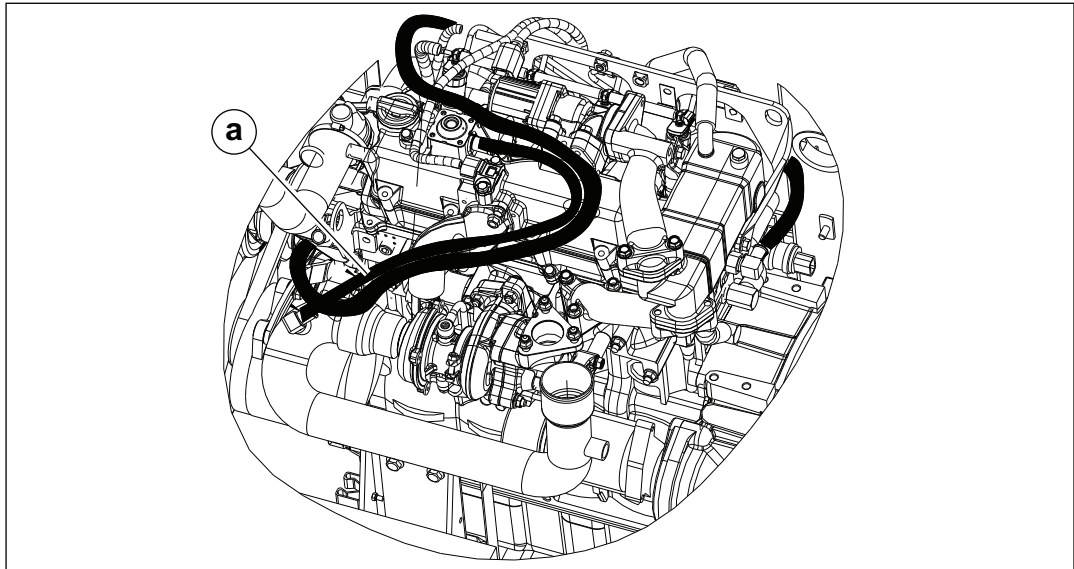

wc_gr013039

2. Remove the vent hose (a).
3. Thaw and drain the vent hose.
4. Clean the vent hose.
5. Reinstall the vent hose.
6. Reinstall the insulation.

7.6 Using the Lugs and the Convenience Receptacles

Overview Loads can be connected to the generator in two different ways:

1. At the connection lugs **(r)**.
Located as shown, behind the lug door, the connection lugs serve as connection points for cables.
2. At the convenience receptacles:
 - 120V/240V twist-lock receptacles **(l)**
 - 120V GFCI duplex receptacles **(m)**

Note: *The convenience receptacles are not protected by the main circuit breaker. They are protected by their own circuit breakers (j, k). Power to the convenience receptacle circuit breakers is available any time the engine is running, even with the main circuit breaker OFF (open).*

Note: *Graphic is representative only. Your machine may vary.*

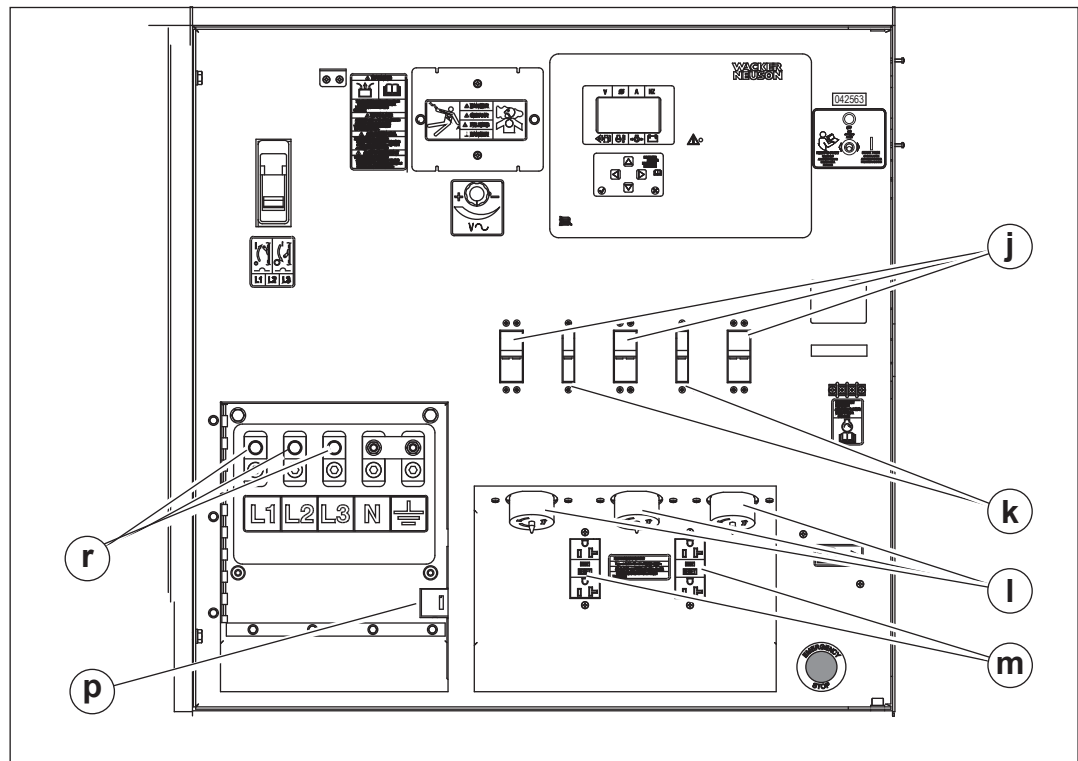

wc_gr010361

Lug door interlock switch

The lug door interlock switch **(p)** is located behind the lug door. The lug door interlock switch is a safety device. When the lug door is opened, the lug door interlock switch trips the main circuit breaker.

Note: *The lug door interlock switch does NOT interrupt power to the convenience receptacles. However, the switch does stop excitation at the generator. The result is significantly reduced voltage at the convenience receptacles.*

Testing a GFCI receptacle

Perform the manual test procedure below before each use to test a GFCI receptacle.

1. Turn the power on at the control panel.
 - A green LED power ON indication light **(a)** will illuminate on the GFCI receptacle.
2. Push the test button **(b)** in.
 - The reset button **(c)** should pop out.
 - Power to the GFCI receptacle should be OFF.
3. Push the reset button in.
 - A green LED power ON indication light will illuminate on the GFCI receptacle.

In addition to the manual test shown above, the GFCI receptacle has a self-test feature. The red LED failure indication light **(d)** will flash if the GFCI receptacle has lost its GFCI protection. Do not use the GFCI receptacle until it is replaced.

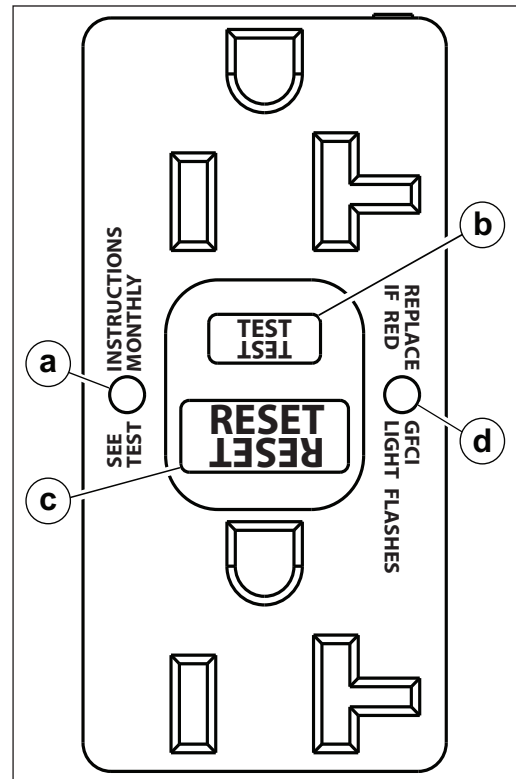

wc_gr014322

7.7 Selecting the Voltage

Location One of two types of voltage selector switch—either three-position (a) or four-position (b)—is mounted to the machine near the lugs.

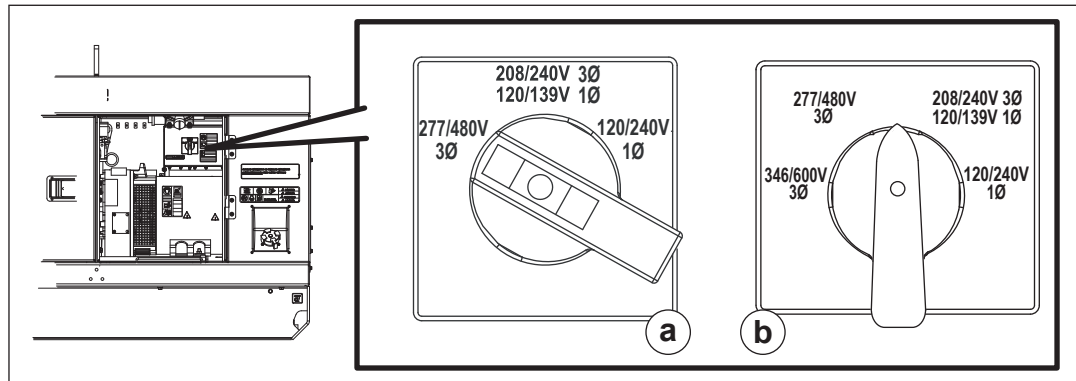

wc_gr011503



WARNING

Electric shock hazard. High voltage is present inside the voltage selector switch enclosure when the engine is running.

- ▶ Do not open the voltage selector switch enclosure unless the engine is stopped.

Selecting the voltage

The chart below lists the ranges of voltages available in each of the switch positions. Select the desired voltage by rotating the handle of the voltage selector switch. Then, use the voltage adjustment rheostat to set the exact voltage you require. The voltage is displayed on the LCD panel.

Switch position	Range of Voltages Available					
	3Ø at lugs (L-L-L)	1Ø at lugs (L-N)	1Ø at lugs (L-L)	1Ø at twist lock		1Ø at GFCI
				L-N (120V)	L-L (240V)	
120/240 VAC 1Ø	—	110–125	220–250	110–125	220–250	110–125
208/240 VAC 3Ø 120/139 VAC 1Ø	190–240	110–139	190–240	110–139	190–240	110–139
277/480 VAC 3Ø	380–480	220–277 ²	190–240 ²	110–139 ²	190–240 ²	110–139 ²
346/600 VAC 3Ø ¹	540–600	—	—	—	—	—

¹ Not available on all models.

² Not available on 600V models.

NOTICE: Do not change the position of the voltage selector switch while the engine is running. Doing so can cause arcing that can damage the voltage selector switch and the generator windings.

This procedure continues on the next page.

Continued from the previous page.

Using the rheostat

The voltage adjustment rheostat (c) is used to fine-tune the voltage as needed while the machine is running.

Note: For 600V machines, before starting the machine with the voltage selector switch in the 346/600 VAC 3Ø mode, change the voltage adjustment rheostat to the desired voltage output ($\geq 540V$). If not correctly adjusted before starting the machine, the controller may turn on the wrong voltage protection settings and shut down.

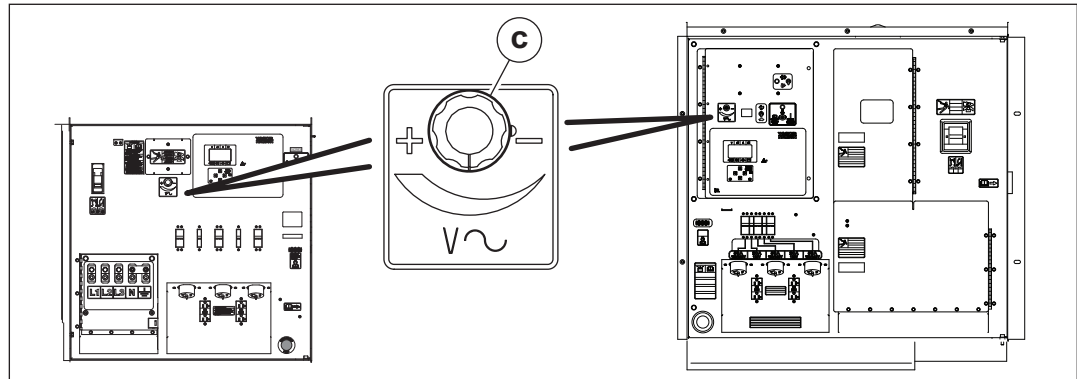

wc_gr011502

Care must be taken when using the voltage adjustment rheostat because adjusting the voltage for 3-phase operation affects the voltage available at the single-phase outlets. As the 3-phase voltage increases, so does the single-phase voltage.

NOTICE: Do not use the GFCI or twist-lock receptacle (120V) when the 1Ø voltage is above 135V. Damage to the receptacle and the tools connected to it may occur.

Switch Position	3Ø Voltage (L-L-L)	Corresponding 1Ø voltage		
		Twist lock receptacle		120V GFCI
		L-L (240V)	L-N (120V)	
208 VAC 3Ø 120 VAC 1Ø	208	208	120	120
	220	220	125	125
	240	240	139 ¹	139 ¹
277/480 VAC 3Ø	480	240	139 ¹	139 ¹
	460	230	133 ²	133 ²
346/600 VAC 3Ø ³	600	—		
	540			

¹ Do not use receptacle with this voltage.

² Voltage may be too high for some tools and equipment. Check tool/equipment specifications.

³ Not available on all models.

7.8 Wet Stacking

Overview Wet stacking is the buildup of unburned diesel fuel, moisture, and carbon particles in the exhaust system of the machine. This occurs when diesel fuel is not completely burned off during use, and a black, oily residue accumulates in the exhaust system due to operating the machine at a light load for extended periods of time.

Wet stacking can lead to reduced engine performance, pollution, premature engine wear, and permanent engine damage.

- Prevention**
- Use the right sized generator for the needs of the job.
 - Follow the maintenance schedule.
 - Load the machine greater than 30% of the engine rating.
 - Run the machine a few minutes per week at the operational temperature.
 - Have the machine regularly serviced by an experienced service technician.
-

- Solution**
- Have the machine serviced by an experienced service technician.
 - Operate the machine at a load of about 75–80% of the machine's nameplate rating for a few hours to raise the exhaust temperature high enough to clean out the exhaust system.

7.9 Before Starting the Machine



WARNING

Personal injury hazard. Failure to follow the listed procedures may cause injury to personnel or damage to the generator.

- ▶ Make sure that all persons setting up the generator are certified or fully trained on the installation of the generator.

Before putting the generator into service, perform each item on the following checklist.

Exterior checks

- Check for damage that may have occurred during towing or travel to the jobsite. Repair any damage.
- Make sure that the generator is level.
- Chock the trailer wheels.

Internal checks

- Check engine oil, coolant, and fuel levels—fill as required.
- Check the fan belt and hoses on the engine for loose connections or fraying—tighten or replace belts and hoses as required.
- Remove any debris that has lodged in vents, near the radiator, or around the fan.
- Make sure the exhaust compartment is clean, with nothing touching the muffler or exhaust pipes.

Pre-operation checks

- Read and understand the engine owner’s manual.
- Check local regulations and NEC standards for electrical connections.
- Determine voltage needs; obtain proper cable and equipment to meet the needs. Follow local regulations and NEC standards.
- Make sure that the generator is grounded to a good earthen ground per local regulations and NEC standards.
- Review and follow the safety instructions found in the front of this Operator’s Manual.

7.10 Starting and Running the Machine



CAUTION

Possibility of injury or equipment damage. Failure to match phase, voltage, and frequency may cause equipment connected to the generator to operate incorrectly.

- ▶ When using the generator as a stand-by or substitute power supply, make sure the phase, voltage, and frequency of the generator matches that of the utility lines or of any other power source normally used.

Preliminary

Perform the procedure below to start and run the machine.

1. Set the engine start switch **(a)** to the OFF position.

Note: *Graphic is representative only. Your machine may vary.*

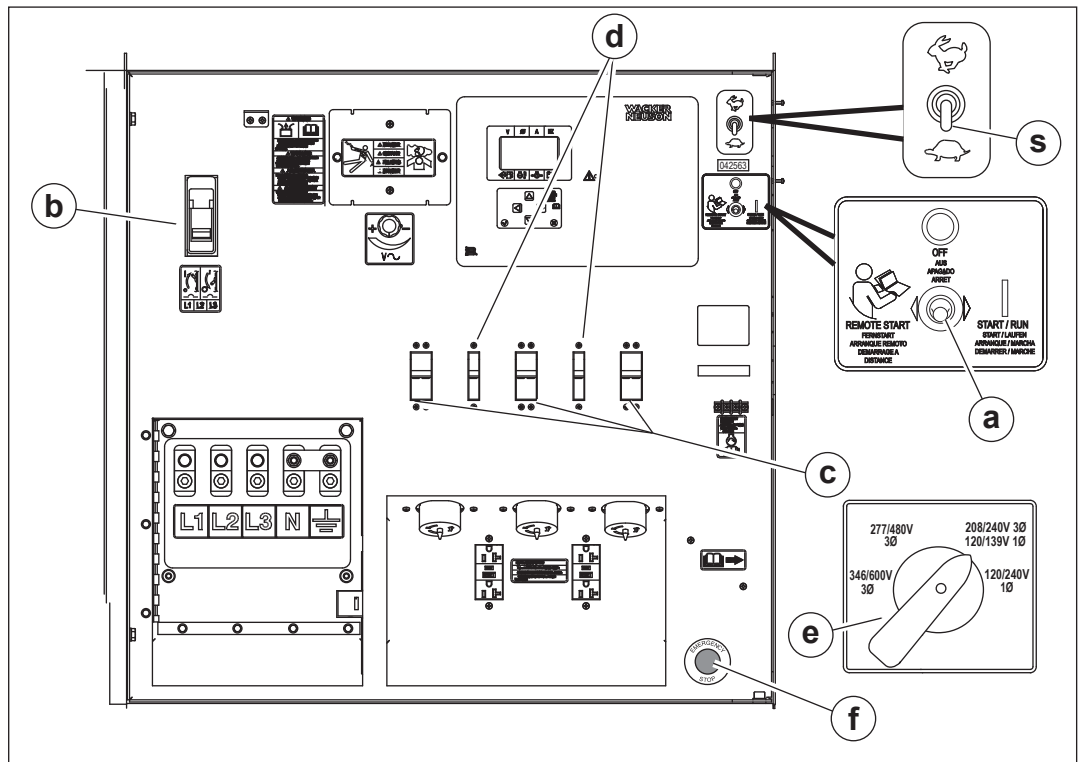

wc_gr011279

2. Set the main circuit breaker **(b)** to OFF.
3. Set the convenience receptacle circuit breakers **(c, d)** to OFF.
4. Turn off all loads.
5. Check position of the voltage selector switch **(e)** and make sure it is set for the desired voltage output. Lock the voltage selector switch in place if desired.

This procedure continues on the next page.

Continued from the previous page.

6. Connect the load to the lugs and/or to the convenience receptacles.
7. Check the operation of the generator controller.
 - a. Set the engine start switch to REMOTE START. The LCD panel momentarily displays **INITIALIZING** followed by **READY**. Engine information is also displayed. Check the fuel level and battery voltage. Add fuel and/or charge the battery if needed. If the LCD display does not power up, check battery voltage and connections.
 - b. With the READY screen showing, press the emergency stop button (f). The LCD panel displays **EMERGENCY STOP**, and the pre-alarm/alarm LED illuminates. If the LCD does not display **EMERGENCY STOP**, do not continue. Contact a Wacker Neuson dealer for assistance. Pull out the emergency stop button after verifying the display.
 - c. Set the engine start switch to OFF.
8. In cold weather, set the idle switch (s) to slow position (turtle), if equipped.

Note: *The generator will not produce electricity in the slow position. The idle switch must be set to the position fast idle (rabbit) in order to produce electricity.*

Starting

9. Start the engine by setting the engine start switch to the START/RUN position.

After displaying **INITIALIZING** and **NOT IN AUTO**, the LCD panel will display **START DELAY** followed by **CRANKING** as the engine begins its crank cycle. The crank cycle calls for the engine to crank for 10 seconds, then rest for 10 seconds. This cycle will repeat three times in an attempt to start the engine.

If the engine does not start within three attempts, the generator controller stops the crank cycle and **OVERCRANK** is displayed on the LCD panel.

- To repeat the crank cycle, set the start switch to OFF, then back to START/RUN.

10. Set the idle to fast position (rabbit), if equipped. Run the engine for a few minutes to allow it to warm before turning on (closing) any circuit breakers.

Upon startup

Upon engine startup, the LCD displays the monitoring screen.

Note: *Leave the engine start switch (a) in the START/RUN position while the generator is operating.*

11. Check the voltage on the monitoring screen and adjust it as needed using the voltage adjustment rheostat. See topic *Selecting the Voltage*.
12. Turn on (close) the appropriate circuit breakers for your load.

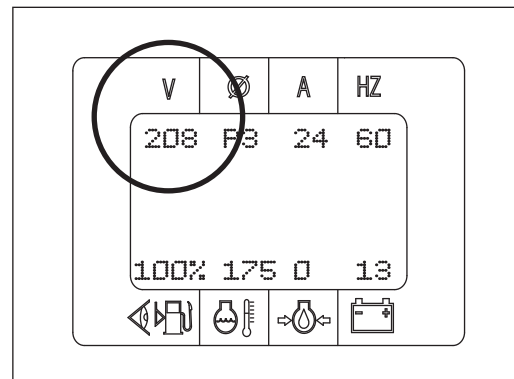

wc_gr010195

7.11 Stopping the Machine

Check with other personnel on the jobsite and let them know that power is being turned off. Make sure that the power shutdown will not create any hazards by turning off devices such as pumps, heaters, or lights that may need to be kept on.

1. Turn off all loads connected to the generator.
2. Set the main circuit breaker to OFF.
3. Set the convenience receptacle circuit breakers to OFF.
4. Let the engine run for approximately ten minutes to cool it down.
5. Set the engine start switch to the OFF position.

7.12 Emergency Stop Switch

Location The emergency stop switch (**a**) is the red button located as shown, and can be accessed with the panel doors closed.

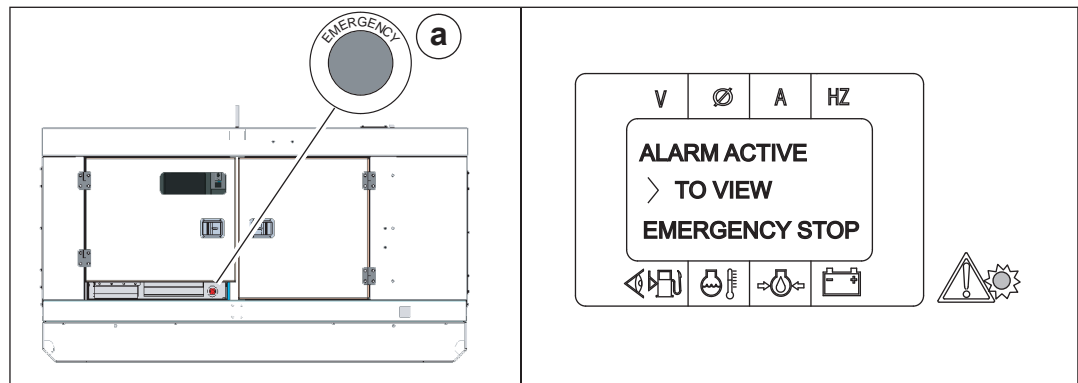

wc_gr010365

Function Activate the emergency stop switch by pushing the red button. Pushing the emergency stop switch:

- turns off (opens) the main circuit breaker
- cuts power to the fuel solenoid
- stops the engine
- causes “Alarm Active: Emergency Stop” to appear on the LCD display

The emergency stop switch will remain activated until the button is pulled out.

NOTICE: Do not use the emergency stop switch to shut down the generator during normal operation. The emergency stop switch is intended for use only in an actual emergency situation where the generator must be stopped immediately.

To shut down the generator during normal operation, turn off (open) the main circuit breaker and then move the engine start switch to the OFF position.

7.13 LCD Panel: Monitoring Machine Operation

Overview

Generator and engine information is continuously monitored and displayed on the LCD panel. The upper line displays generator information. The lower line displays engine information.

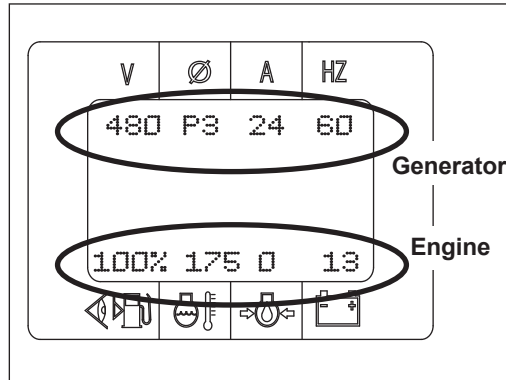

wc_gr010202

Generator information

The upper line of the LCD panel shows the voltage, phase, amperage, and frequency of the electric power being generated. The information is shown only when the engine is running.





Symbol	Meaning	Description
V	Volts	Displays the value of the AC output voltage being produced by the generator.
Ø	Phase	Displays the leg or phase currently being monitored. In three-phase mode, the display toggles between P1, P2, and P3. In single-phase mode, the display toggles between L1, L3, and L-L.
A	Amps	Displays the value of the AC output amperage produced by the generator. If the generator is operating at no load, output amperage will be zero (0).
HZ	Frequency in Hertz	Displays the value of the output frequency. For tier 3 engines, this display will read approximately 61.5 Hz under a no-load condition and approximately 60 Hz under load. For tier 4 engines, this display will read approximately 60.0 Hz under no-load and loaded conditions.

This procedure continues on the next page.

Continued from the previous page.

Engine information

The lower line of the LCD panel shows fuel level, temperature, oil pressure, and battery voltage. The information is shown when the engine start switch is set to REMOTE START or RUN/START.

Symbol	Meaning	Description
	Fuel level	Indicates relative fuel level in the fuel tank
	Temperature	Displays temperature of engine coolant
	Oil pressure	Displays engine oil pressure between 0 and 100 psi Normal operating pressure = 50–80 psi
	Battery voltage	Displays real-time battery voltage while the machine is operating Actual battery voltage is displayed when the engine switch is set to REMOTE START and the generator is in standby mode.

8 Working with Basler Controller

8.1 How to Use the Generator Controller LCD and Keypad

Basics

The LCD (a) is used to display information regarding machine performance and operating status. The keypad (b) is used to maneuver through the various menus of the generator controller. The keypad is also used to enter and change values of machine settings.

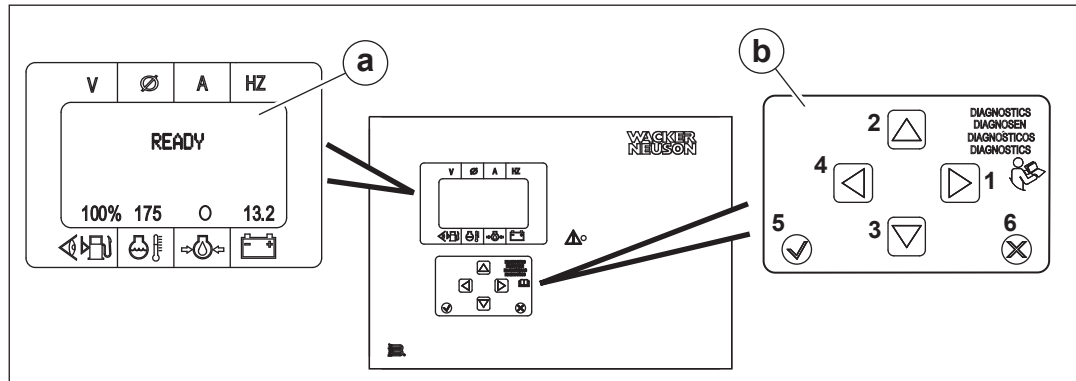

wc_gr010130

Actions of the buttons

To scroll through the options within a menu, use the up/down arrow buttons (2, 3).

When an option on a menu is highlighted, it can be accessed for further submenus. To do so, press the right arrow button (1).

To return to a previous screen, press the left arrow button (4).

To exit menu navigation and return to monitoring status (or the READY screen), press and hold the left arrow button.

To access a setting in order to change it, press the check mark button (5).

To cancel an operation, press the "X" reset button (6).

Normal screens

The machine must be running, or the start switch set to REMOTE START position, for the generator to be on and active. Sample screens of normal operation are shown below.

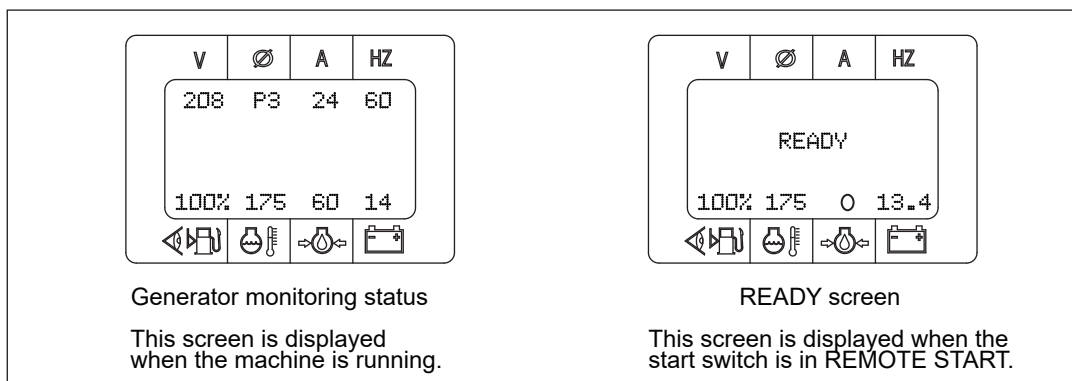

wc_gr010144

8.2 Menu Diagram of the Generator Controller

The various menus of the generator controller are divided into two main categories: METERING and SETTINGS. Access to the METERING menu and to the SETTINGS menu is done through the MAIN MENU. To access the MAIN MENU from either the monitoring screen or the READY screen, press the right arrow button.

Note: *Graphic is representative only. Your machine may vary.*

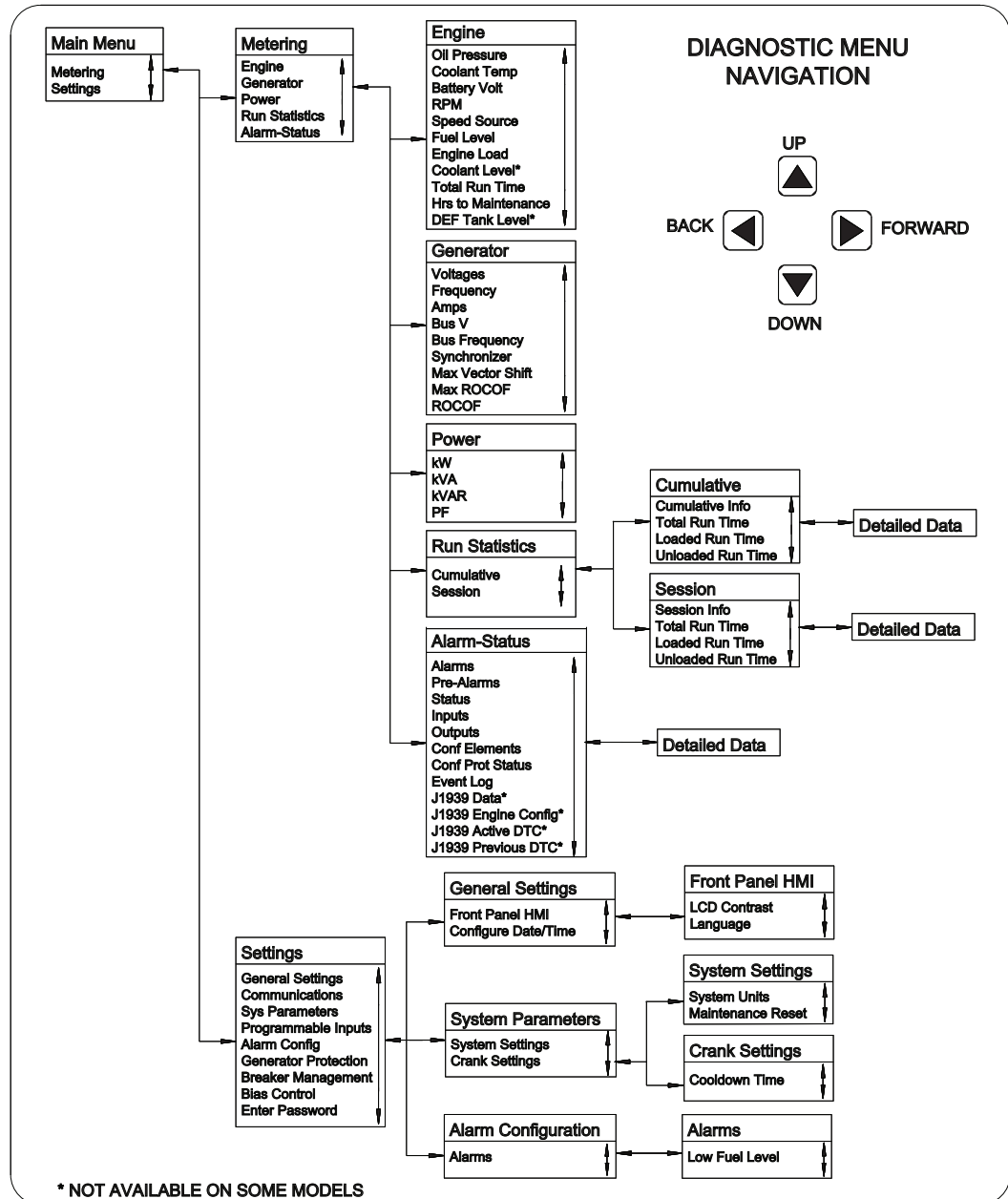

wc_gr007618

8.3 Menu Diagram Components

Menu Item	Description	Menu Item	Description
Alarm Config	Alarm configuration	J1939 Active DTC	Diagnostic Trouble Codes
Alarm Configuration	—	J1939 Data	—
Alarms	—	J1939 Engine Config	Engine configuration
Alarm–Status	—	J1939 Previous DTC	Diagnostic Trouble Codes
Amps	—	kVA	Kilovolt-amps
Back	—	kVAR	Kilovolt-amps Reactive
Battery Volt	—	kW	Kilowatts
Bias Control	—	Language	—
Breaker Management	—	LCD Contrast	Liquid Crystal Display
Bus Frequency	—	Loaded Run Time	—
Bus V	Bus voltage	Low Fuel Level	—
Communications	—	Main Menu	—
Conf Elements	Configurable elements	Maintenance Reset	—
Conf Prot Status	Configurable protection status	Metering	—
Configure Date/Time	—	Oil Pressure	—
Coolant Level	—	Outputs	—
Coolant Temp	—	PF	Power factor
Cooldown Time	—	Power	—
Crank Settings	—	Pre-Alarms	—
Cumulative	—	Programmable Inputs	—
Cumulative Info	—	RPM	Rotations per minute
Detailed Data	—	Run Statistics	—
Diagnostic Menu Navigation	—	Session	—
Down	—	Session Info	—
Engine	—	Settings	—
Engine Load	—	Speed Source	—
Enter Password	—	Status	—
Event Log	—	Synchronizer	—
Forward	—	Sys Parameters	System parameters
Frequency	—	System Settings	—
Front Panel HMI	Human-Machine Interface	System Units	—
Fuel Level	—	Total Run Time	—
General Settings	—	Unloaded Run Time	—

Menu Item	Description	Menu Item	Description
Generator	—	Up	—
Generator Protection	—	Voltages	—
Hrs to Maintenance	Hours to maintenance	—	—
Inputs	—	—	—

8.4 Using the Metering and Settings Menus

Background The various menus of the generator controller are divided into two main categories: METERING and SETTINGS. Access to the METERING menu and to the SETTINGS menu is done through the MAIN MENU.

METERING menus METERING menus give detailed information regarding engine status and generator performance. The machine must be running for many of the parameters to be active. Use the menu diagram of the generator controller as a guide for navigating the menus.

Parameters under the METERING menu are read-only. They cannot be changed, except for HRS to MAINTENANCE parameter, which can be reset.

SETTINGS menus SETTINGS menus give detailed information regarding generator controller configuration. Use the menu diagram of the generator controller as a guide for navigating the menus.

There are a limited number of parameters under the SETTINGS menus that may be changed by the user. These parameters are:

- LCD screen contrast
- Time and date
- Sender fail time delays
- Units of measure (imperial or metric)
- Low fuel pre-alarm level
- Low fuel alarm level
- Cooldown time
- Pre-crank time delay
- Maintenance interval

Procedures for changing these parameters are included in this manual.

8.5 Logging in to the Generator Controller by Entering the Password

Precaution Only change parameters when the READY screen is displayed (start switch in the REMOTE START position).

Password In order to change the parameters under the settings menu, you must be “logged in” to the generator controller. There are two displays where you can log in to the generator controller: 1) at the “ENTER PASSWORD” display under SETTINGS; or 2) when prompted for the password by the generator controller at the parameter you want to change.

The default password, in either case, is “OP”. It is set at the factory. It is the only password available, and it cannot be changed.

Once you are logged in, you will remain logged in until:

- you log out,
- the machine is turned off,
- or if you press the check mark button inadvertently. This usually happens when attempting to change a locked parameter.

At ENTER PASSWORD

To log in to the generator controller at the ENTER PASSWORD display, do the following:

1. Press the right arrow button **(1)** to enter the main menu.

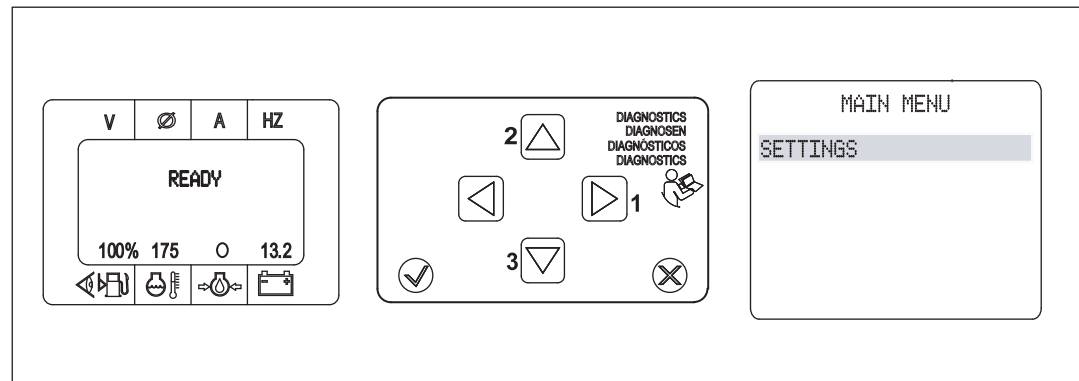

wc_gr010119

2. Use the up/down arrow buttons **(2, 3)** to highlight SETTINGS. Then, press the right arrow button.

This procedure continues on the next page.

Continued from the previous page.

- Using the up/down arrow buttons, scroll through the setting parameters until ENTER PASSWORD is highlighted. Then, press the check mark button (5).

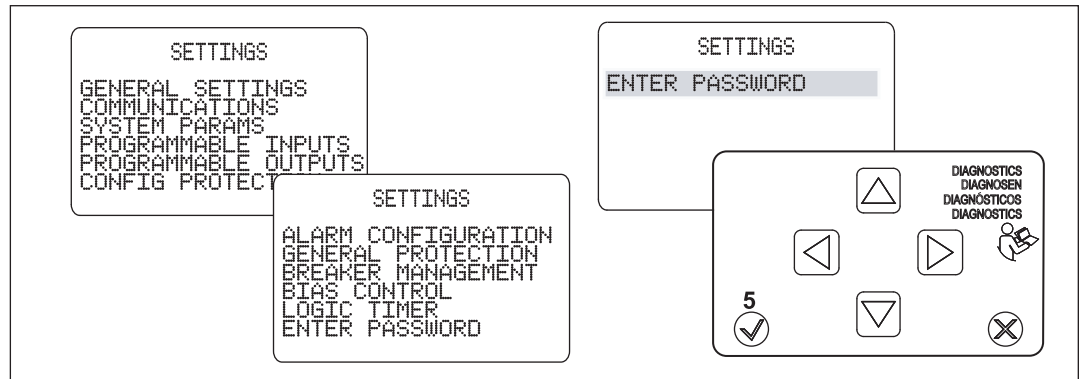

wc_gr010120

- The password entry screen appears with a letter "A" as the default character. Use the up/down arrow buttons to change the "A" to "O". Then, press the right arrow button to move the cursor to the next position.

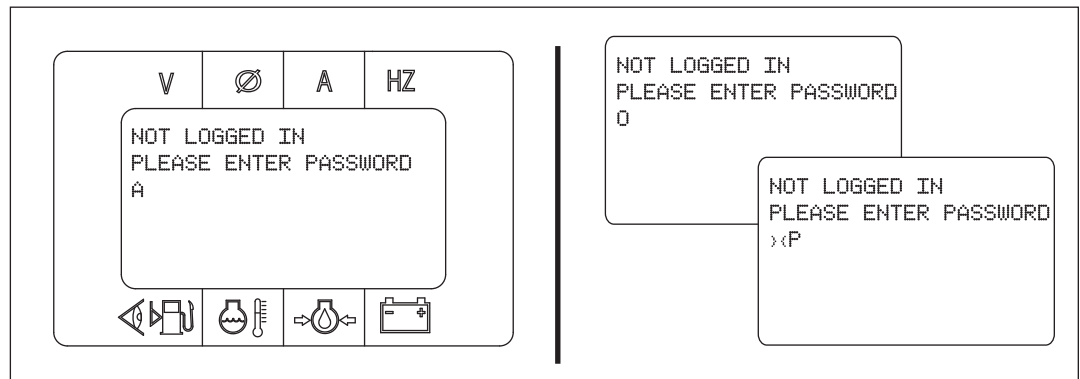

wc_gr010121

- Use the up/down buttons to select "P". Then, press the check mark button.

The screen below appears. You are now logged in and have the ability to change parameter settings. Do not re-enter the password even though it is requested; instead, navigate to the parameter you would like to change. You may, however, log out if desired. To do so, navigate to LOGOUT and press the check mark button.

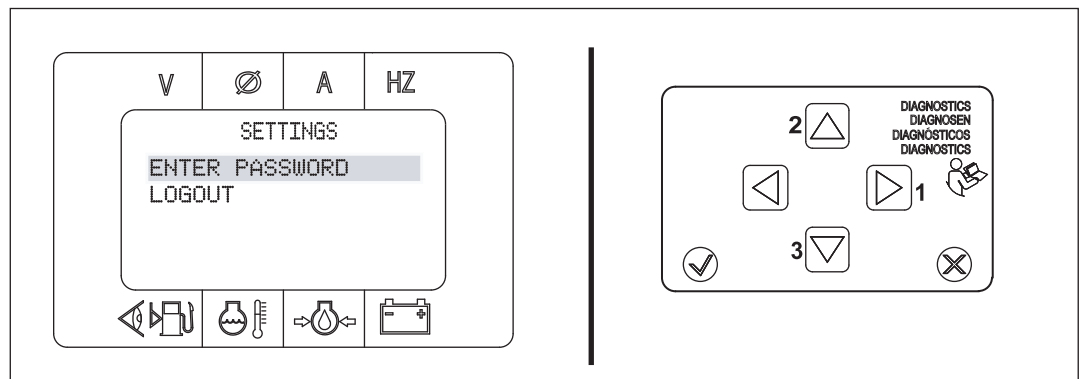

wc_gr010122

This procedure continues on the next page.

Continued from the previous page.

At the PASSWORD prompt

To log in when prompted to enter the password, do the following:

1. The password entry screen appears with a letter “A” as the default character. Use the up/down arrow buttons to change the “A” to “O”. Then, press the right arrow button to move the cursor to the next position.

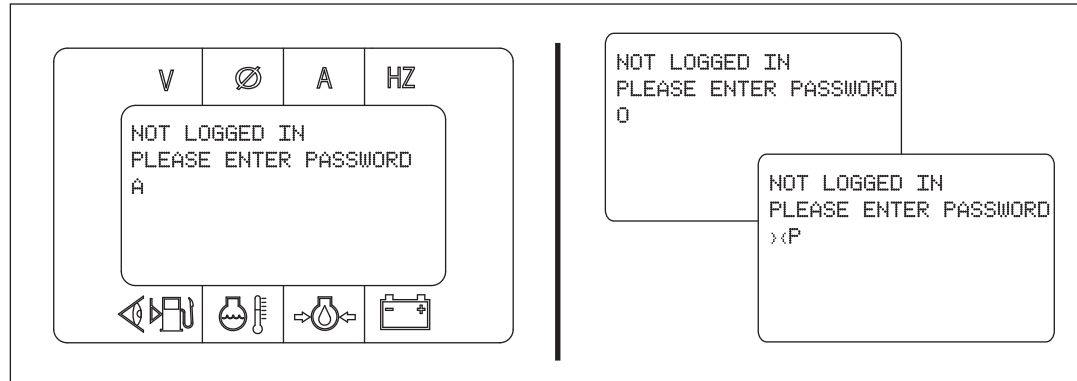

wc_gr010121

2. Use the up/down arrow buttons to select “P”. Then, press the check mark button.
3. A screen for the parameter, similar to that shown below left (A), will appear. The word “~~EDIT~~” will be displayed. Whenever “~~EDIT~~” is displayed, it means that you are able to change the parameter. Use the up/down arrow buttons to change the setting. Then, press the check mark button to accept the new value.

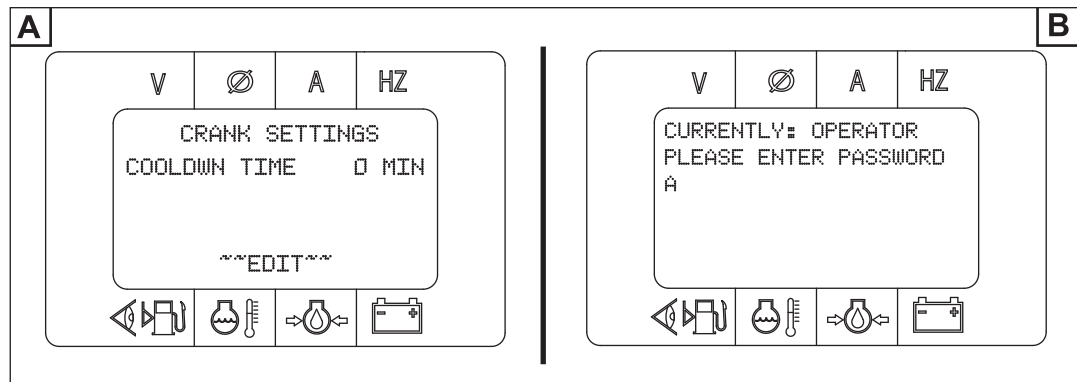

wc_gr010128

Note: If the generator controller displays the screen (B), it means that the parameter cannot be changed by the operator. Do not re-enter the password even though you are requested to do so; instead, press the “X” button to cancel the operation and return to the previous screen. If you do re-enter the password (by pressing the check mark button), you will be logged out. In such cases, turn the machine off, then back on again, and restart the procedure from the beginning.

8.6 Adjusting the LCD Screen Contrast

- Requirements**
- Machine stopped
 - Start switch in REMOTE START

Note: Internal programming of the generator controller, or closed connections to a remote start switch, may cause the machine to start unexpectedly. Be prepared for the engine to start even with the engine start switch in the REMOTE START position.

Procedure Perform the procedure below to adjust the LCD screen contrast.

1. Press the right arrow button (1) to access the MAIN MENU.

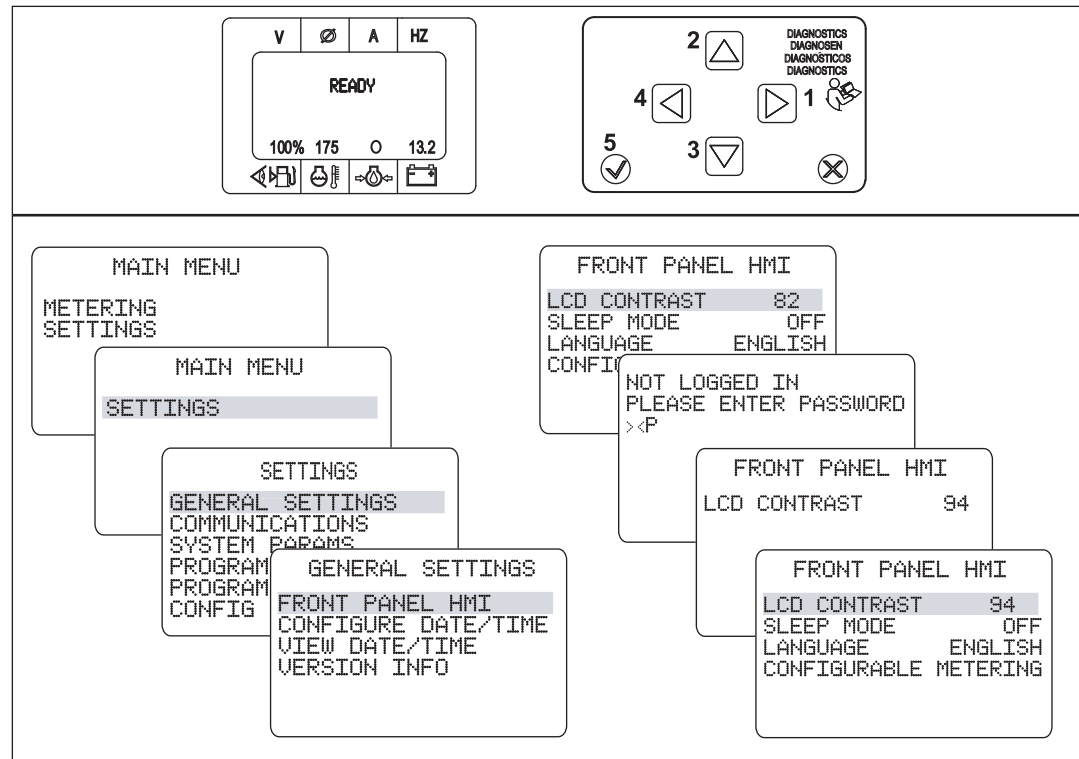

wc_gr010132

2. Using the up/down arrow buttons (2, 3) highlight SETTINGS. Then, press the right arrow button.
3. Highlight GENERAL SETTINGS. Then, press the right arrow button (1).
4. Highlight FRONT PANEL HMI. Then, press the right arrow button.
5. Highlight LCD CONTRAST. Then, press the check mark button (5).
6. If you are not logged in, enter the password “OP”. Press the check mark button.
7. Using the up/down arrow buttons, change the contrast value as desired. Press the check mark button when finished.
8. Exit by pressing the left arrow button (4) twice or until the LCD displays the SETTINGS menu. Then, scroll to LOGOUT and press the check mark button. Press the left arrow button until the READY screen appears.

8.7 Changing the Time/Date Settings

- Requirements**
- Machine stopped
 - Start switch in REMOTE START

Note: Internal programming of the generator controller, or closed connections to a remote start switch, may cause the machine to start unexpectedly. Be prepared for the engine to start even with the engine start switch in the REMOTE START position.

Procedure Perform the procedure below to change the time and date.

1. Press the right arrow button **(1)** to access the MAIN MENU.

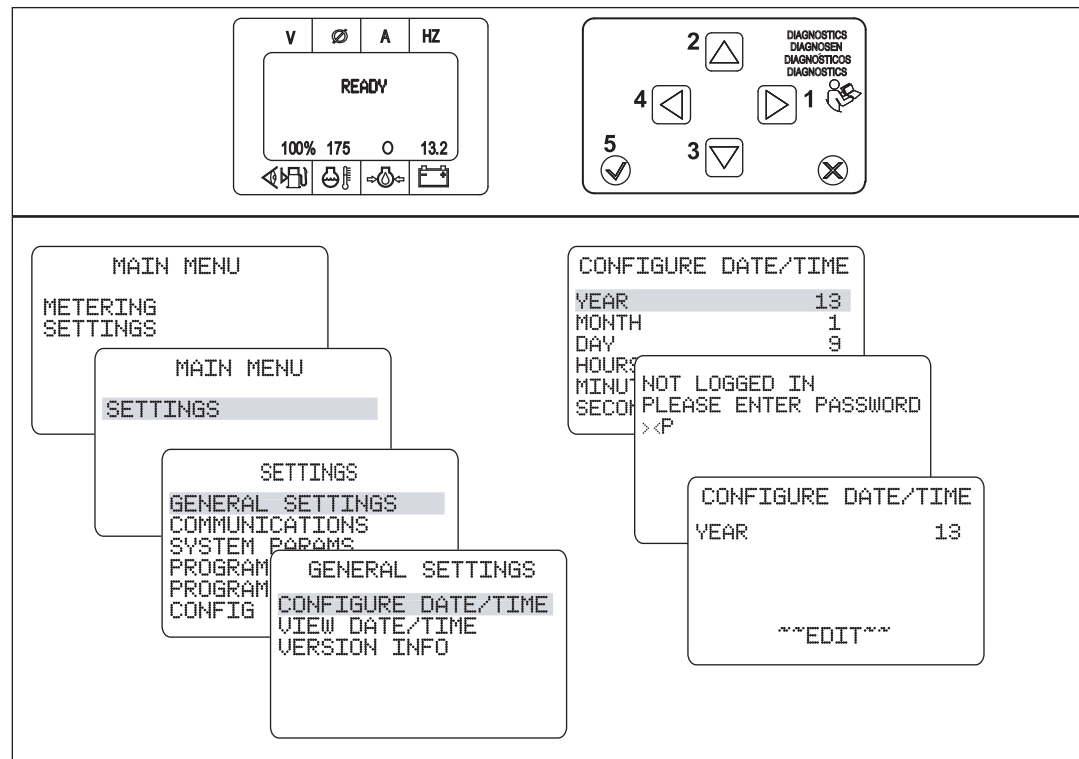

wc_gr010133

2. Using the up/down arrow buttons **(2, 3)** highlight SETTINGS. Then, press the right arrow button.
3. Highlight GENERAL SETTINGS. Then, press the right arrow button **(1)**.
4. Highlight CONFIGURE DATE/TIME. Then, press the right arrow button.
5. Highlight the setting you want change. Then, press the check mark button **(5)**.
6. If you are not logged in, enter the password "OP". Press the check mark button.
7. Using the up/down arrow buttons, change the value as desired. Press the check mark button when finished.
8. Exit by pressing the left arrow button **(4)** twice or until the LCD displays the SETTINGS menu. Then, scroll to LOGOUT and press the check mark button. Press the left arrow button so that the READY screen appears.

8.8 Changing the Sender Fail Time Delays

- Requirements**
- Machine stopped
 - Start switch in REMOTE START

Note: *Internal programming of the generator controller or connections to a remote start switch may cause the machine to start unexpectedly. Be prepared for the engine to start even with the engine start switch in the REMOTE START position.*

Background There are five senders/sensors monitored by the generator controller. Each has its own failure-time-delay period. This is the amount of time that the generator controller must experience the failure before the failure will be seen on the LCD display. These failure-time-delay periods may be changed. The table below lists the failure-time-delay periods, the allowable range, and their factory settings.

Failure Time Delay	Range	Factory Setting
Coolant temperature sender	0 to 30 min	5 min
Oil pressure sender	0 to 300 sec	10 sec
Fuel level sender	0 to 300 sec	10 sec
Voltage sensor	0 to 300 sec	15 sec
Speed sender	0 to 300 sec	300 sec

This procedure continues on the next page.

Continued from the previous page.

Procedure Perform the procedure below to change a fail time delay.

1. Press the right arrow button **(1)** to access the MAIN MENU.

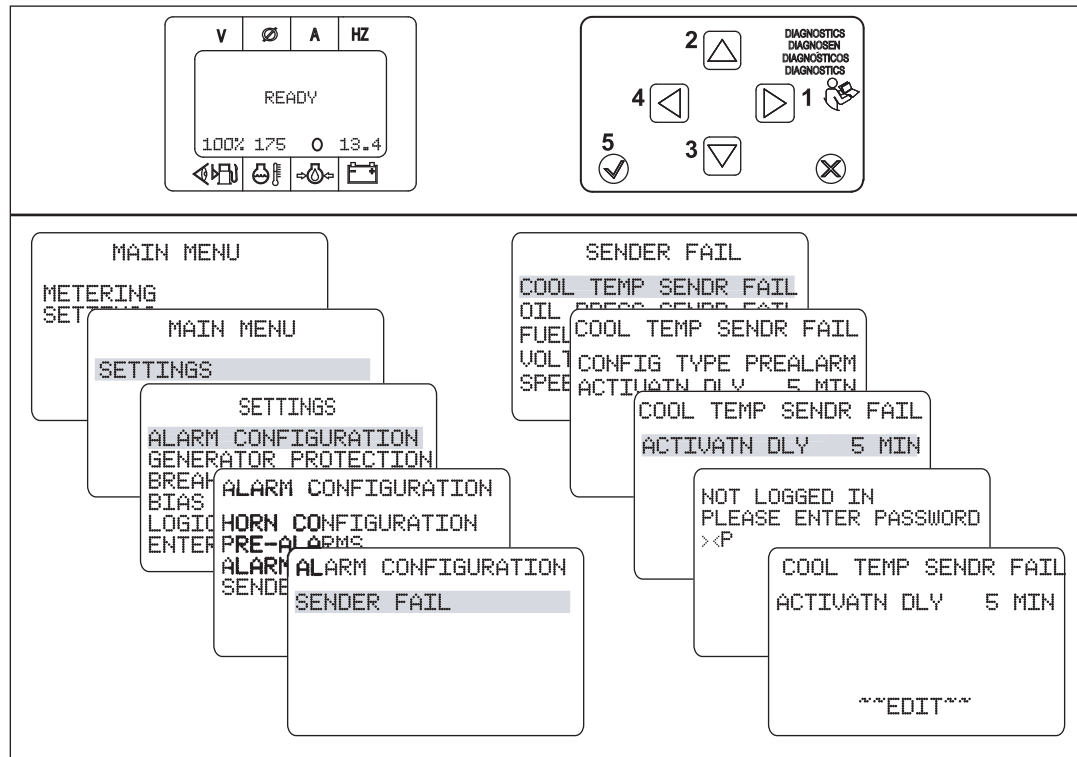

wc_gr010134

2. Using the up/down arrow buttons **(2, 3)**, highlight SETTINGS. Then, press the right arrow button.
3. Highlight ALARM CONFIGURATION. Then, press the right arrow button.
4. Highlight SENDER FAIL. Then, press the right arrow button.
5. Highlight the sender or sensor you want to change. Then, press the right arrow button.
6. Highlight ACTIVATN DELAY or TIME DELAY. Then, press the check mark button **(5)**.
7. If you are not logged in, enter the password "OP". Press the check mark button.
8. Using the up/down arrow buttons, change the value as desired. Press the check mark button when finished.
9. Exit by pressing the left arrow button **(4)** three times or until the LCD displays the SETTINGS menu. Then, scroll to LOGOUT and press the check mark button. Press the left arrow button so that the READY screen appears.

8.9 Changing the Units of Measure

- Requirements**
- Machine stopped
 - Start switch in REMOTE START

Note: Internal programming of the generator controller, or closed connections to a remote start switch, may cause the machine to start unexpectedly. Be prepared for the engine to start even with the engine start switch in the REMOTE START position.

Background Generator controller units of measure may be set to English (imperial) or metric.

Procedure Perform the procedure below to set the units of measure.

1. Press the right arrow button **(1)** to access the MAIN MENU.

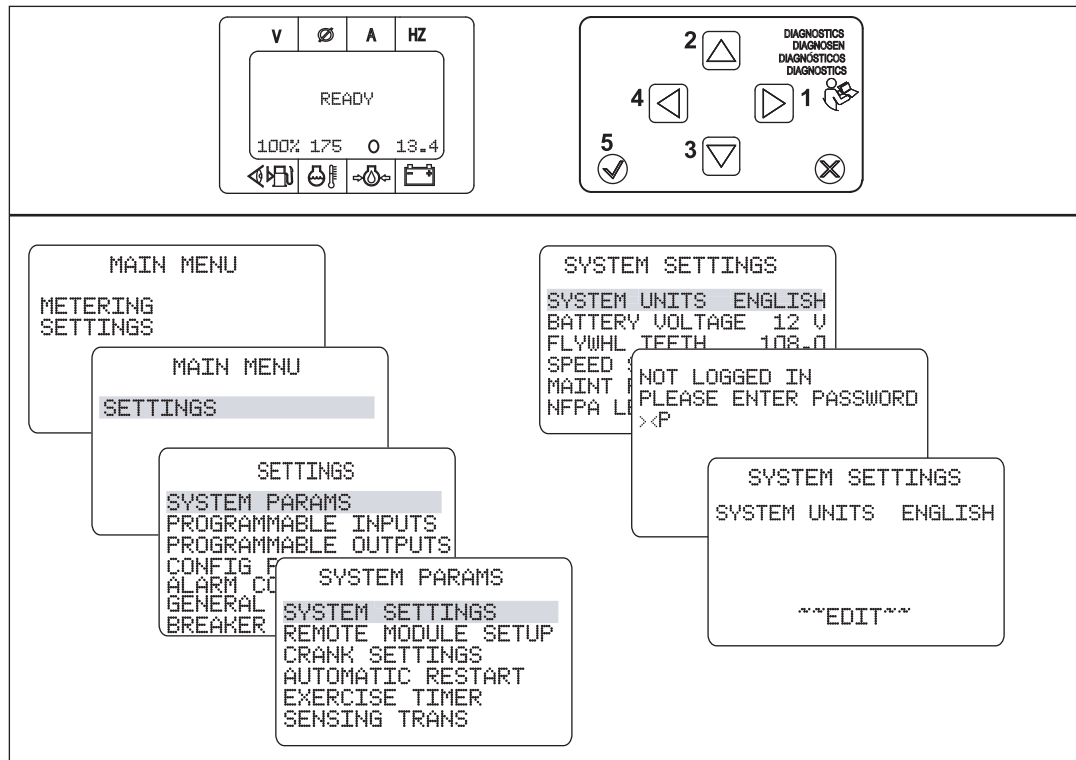

wc_gr010135

2. Using the up/down arrow buttons **(2, 3)**, highlight SETTINGS. Then, press the right arrow button.
3. Highlight SYSTEM PARAMS. Then, press the right arrow button.
4. Highlight SYSTEM SETTINGS. Then, press the right arrow button.
5. Highlight the SYSTEM UNITS. Then, press the check mark button **(5)**.
6. If you are not logged in, enter the password "OP". Press the check mark button.
7. Using the up/down arrow buttons, change the value as desired. Press the check mark button when finished.
8. Exit by pressing the left arrow button **(4)** twice or until the LCD displays the SETTINGS menu. Then, scroll to LOGOUT and press the check mark button. Press the left arrow button so that the READY screen appears.

8.10 Changing the Low Fuel Pre-Alarm Setting

- Requirements**
- Machine stopped
 - Start switch in REMOTE START

Note: Internal programming of the generator controller, or closed connections to a remote start switch, may cause the machine to start unexpectedly. Be prepared for the engine to start even with the engine start switch in the REMOTE START position.

Background The low fuel pre-alarm setting may be changed if desired. The value shown by the generator controller is the percentage of fuel remaining in the fuel tank. The range allowed by the generator controller is 10–100.

Procedure Perform the procedure below to change the low fuel pre-alarm setting.

1. Press the right arrow button **(1)** to access the MAIN MENU.

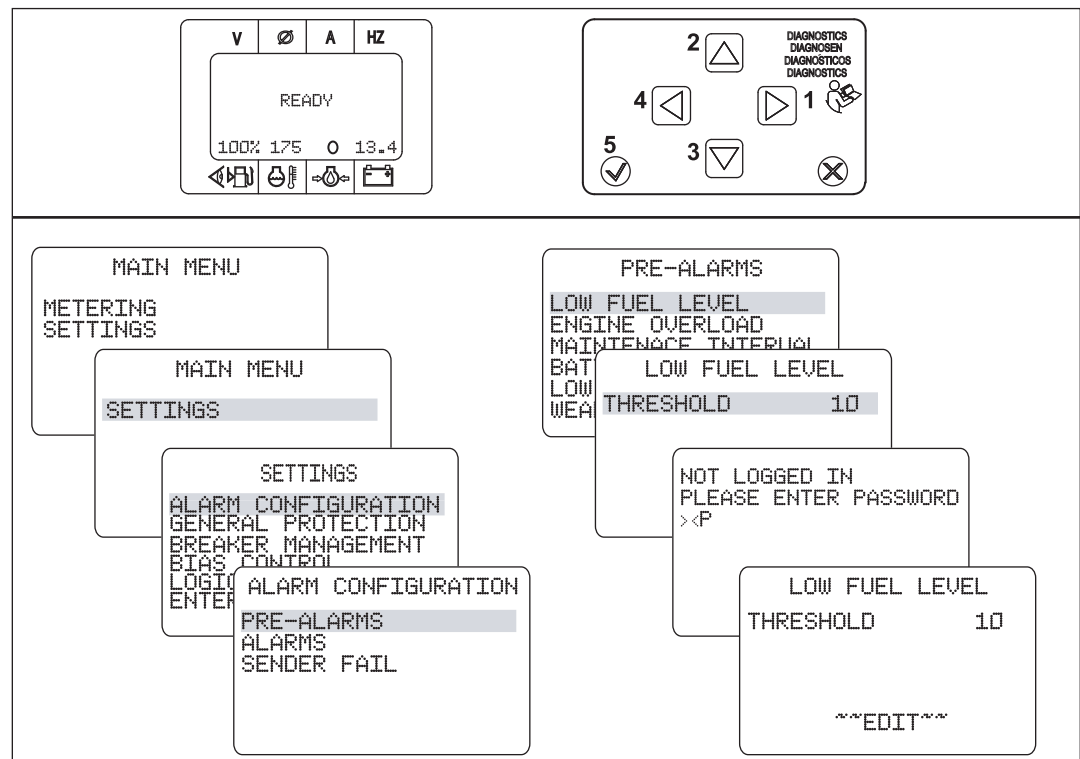

wc_gr010136

2. Using the up/down arrow buttons **(2, 3)**, highlight SETTINGS. Then, press the right arrow button.
3. Highlight ALARM CONFIGURATION. Then, press the right arrow button.
4. Highlight PRE-ALARMS. Then, press the right arrow button.
5. Highlight the LOW FUEL LEVEL. Then, press the right arrow button.
6. Highlight the THRESHOLD. Then, press the check mark button **(5)**.
7. If you are not logged in, enter the password "OP". Press the check mark button.

This procedure continues on the next page.

Continued from the previous page.

8. Using the up/down arrow buttons, change the value as desired. Press the check mark button when finished.
9. Exit by pressing the left arrow button **(4)** three times or until the LCD displays the SETTINGS menu. Then, scroll to LOGOUT and press the check mark button. Press the left arrow button so that the READY screen appears.

8.11 Changing or Disabling the Low Fuel Alarm Setting

- Requirements**
- Machine stopped
 - Start switch in REMOTE START

Note: *Internal programming of the generator controller, or closed connections to a remote start switch, may cause the machine to start unexpectedly. Be prepared for the engine to start even with the engine start switch in the REMOTE START position.*

Background

The LCD panel displays, in percentage, how much fuel is in the fuel tank. The low fuel alarm shutdown is set at the factory to activate at 6%. This value may be changed if desired. For example, you may wish to reduce the low fuel alarm setting so that the machine operates for a longer period of time or until virtually all fuel is consumed before the generator controller shuts down the machine for lack of fuel. The range allowed by the generator controller is 0–100%.

Notes

- Do not set the low fuel alarm to a value greater than that of the low fuel pre-alarm. Doing so will nullify the function of the low fuel pre-alarm.
- Setting the low fuel alarm below 5, in effect, disables the low fuel alarm. The generator controller will not shut down the machine. The machine will shut down when all fuel is consumed.
- “5” is the lowest value the LCD will display.

NOTICE: If the low fuel alarm is set below 5, it is possible to run the fuel so low that air will be drawn into the engine. The fuel system may then need to be bled before it will start and run.

Approximate run time (at 100% prime load) gained with low fuel alarm set to 0%.

Machine	Fuel Use gal/hr	Time Gained hr
G25	1.8	3.7
G25 ERT	1.8	4.2
G50	3.4	3.0
G50 ERT	3.4	3.8
G70	4.9	2.1
G70 ERT	4.9	2.6
G100	6.2	3.3
G120	7.44	2.7
G150	8.85	3.4
G180	10.8	2.7
G240	13.5	2.1

Procedure Perform the procedure below to change the low fuel alarm setting.

1. Press the right arrow button **(1)** to access the MAIN MENU.

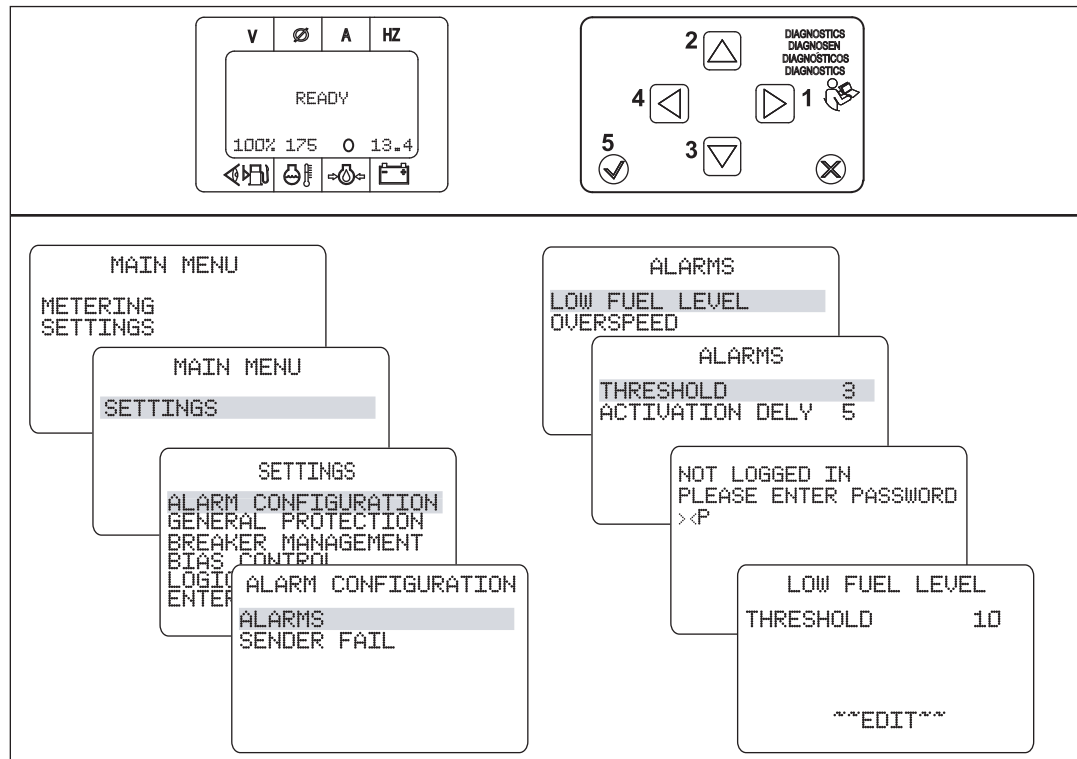

wc_gr010137

2. Using the up/down arrow buttons **(2, 3)** highlight SETTINGS. Then, press the right arrow button. Highlight ALARM CONFIG. Then, press the right arrow button.
3. Highlight ALARMS. Then, press the right arrow button.
4. Highlight the LOW FUEL LEVEL. Then, press the right arrow button.
5. Highlight the THRESHOLD. Then, press the check mark button **(5)**.
6. If you are not logged in, enter the password “OP”. Press the check mark button.
7. Using the up/down arrow buttons, change the value as desired. Press the check mark button when finished.
8. Exit by pressing the left arrow button **(4)** three times or until the LCD displays the SETTINGS menu. Then, scroll to LOGOUT and press the check mark button. Press the left arrow button so that the READY screen appears.

8.12 Changing the Cooldown Time Setting

- Requirements**
- Machine stopped
 - Start switch in REMOTE START

Note: Internal programming of the generator controller, or closed connections to a remote start switch, may cause the machine to start unexpectedly. Be prepared for the engine to start even with the engine start switch in the REMOTE START position.

Background The generator controller includes a cooldown timer. The function of the cooldown timer is to run the engine at no load after a period of being run at load. It is used in conjunction with the remote start system. The cooldown timer activates when the machine is no longer receiving a remote run signal. This timer is factory set to zero (0) minutes. The cooldown time can be changed if desired.

Procedure Perform the procedure below to change the cooldown time setting.

1. Press the right arrow button **(1)** to access the MAIN MENU.

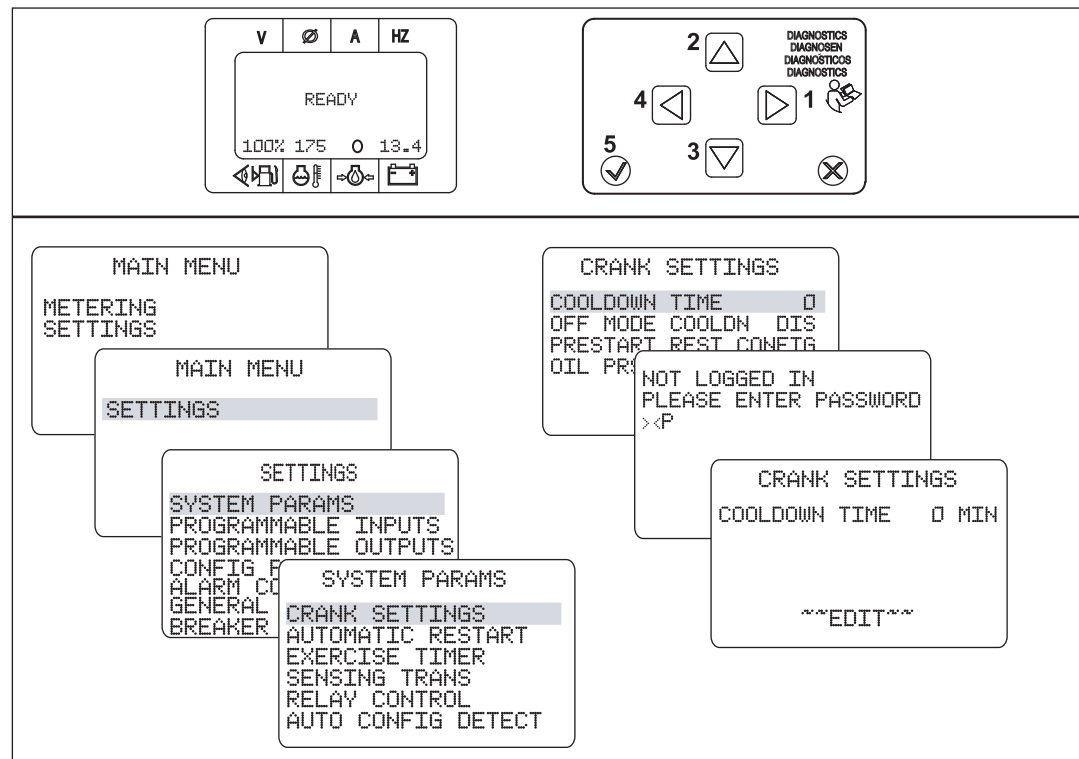

wc_gr010139

2. Using the up/down arrow buttons **(2, 3)**, highlight SETTINGS. Then, press the right arrow button.
3. Highlight SYSTEM PARAMS. Then, press the right arrow button.

This procedure continues on the next page.

Continued from the previous page.

4. Highlight CRANK SETTINGS. Then, press the right arrow button.
5. Highlight COOLDOWN TIME. Then, press the check mark button **(5)**.
6. If you are not logged in, enter the password "OP". Press the check mark button.
7. Using the up/down arrow buttons, change the value as desired. Press the check mark button when finished.
8. Exit by pressing the left arrow button **(4)** twice or until the LCD displays the SETTINGS menu. Then, scroll to LOGOUT and press the check mark button. Press the left arrow button so that the READY screen appears.

8.13 Changing the Pre-Crank Time Delay (Glow Plug Timer)

- Requirements**
- Machine stopped
 - Start switch in REMOTE START

Note: *Internal programming of the generator controller, or closed connections to a remote start switch, may cause the machine to start unexpectedly. Be prepared for the engine to start even with the engine start switch in the REMOTE START position.*

Background

The generator controller includes a pre-crank time delay. This is the time the glow plugs will be on before the engine starts to crank. The factory setting is 5 seconds. The pre-crank time delay can be changed if desired.

NOTICE: Do not set the glow plug timer to a value of more than 10. Damage to the glow plugs may occur.

Procedure Perform the procedure below to change the pre-crank time delay.

1. Press the right arrow button **(1)** to access the MAIN MENU.

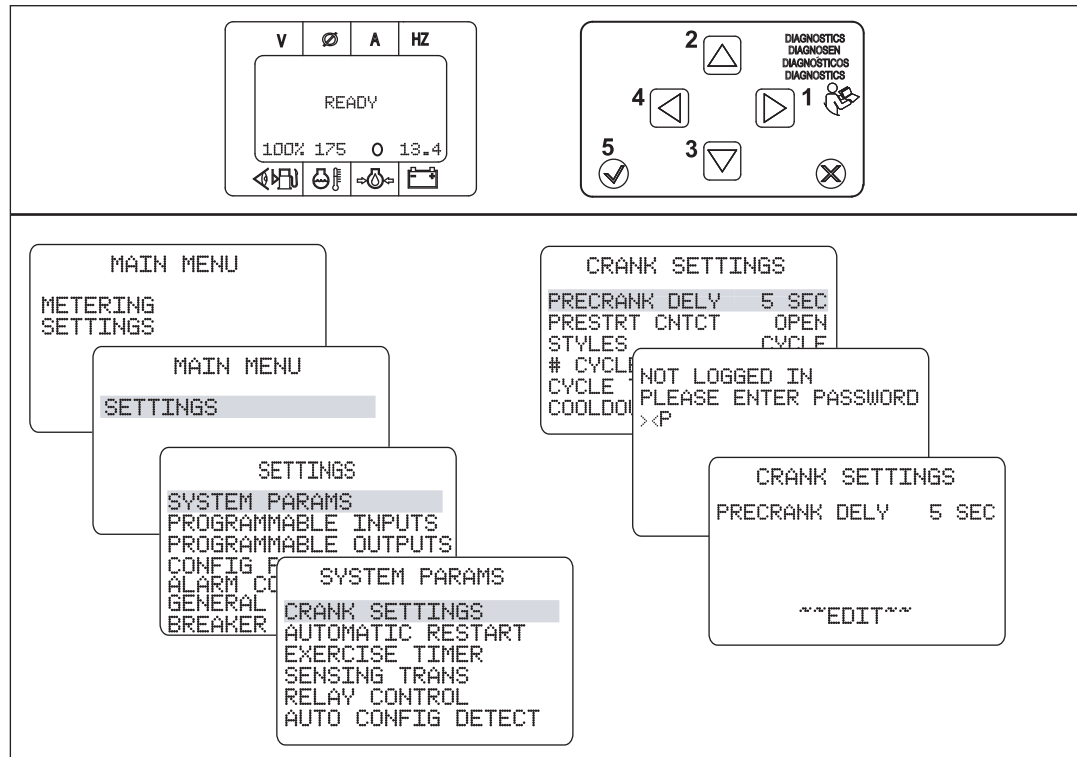

wc_gr010140

2. Using the up/down arrow buttons **(2, 3)** highlight SETTINGS. Then, press the right arrow button.
3. Highlight SYSTEM PARAMS. Then, press the right arrow button.
4. Highlight CRANK SETTINGS. Then, press the right arrow button.
5. Highlight PRECRANK DELY. Then, press the check mark button **(5)**.
6. If you are not logged in, enter the password "OP". Press the check mark button.
7. Using the up/down arrow buttons, change the value as desired. Press the check mark button when finished.
8. Exit by pressing the left arrow button **(4)** twice or until the LCD displays the SETTINGS menu. Then, scroll to LOGOUT and press the check mark button. Press the left arrow button until the READY screen appears.

8.14 Changing the Maintenance Interval

- Requirements**
- Machine stopped
 - Start switch in REMOTE START

Note: Internal programming of the generator controller, or closed connections to a remote start switch, may cause the machine to start unexpectedly. Be prepared for the engine to start even with the engine start switch in the REMOTE START position.

Background The maintenance interval is the time, in hours, scheduled between critical maintenance tasks (such as, changing the engine oil). The amount of time may be changed if desired. The factory setting is 250.

Note: Refer to the Periodic Maintenance Schedule in the Operator's Manual for timing of all scheduled maintenance tasks.

Procedure Perform the procedure below to change the maintenance interval.

1. Press the right arrow button **(1)** to access the MAIN MENU.

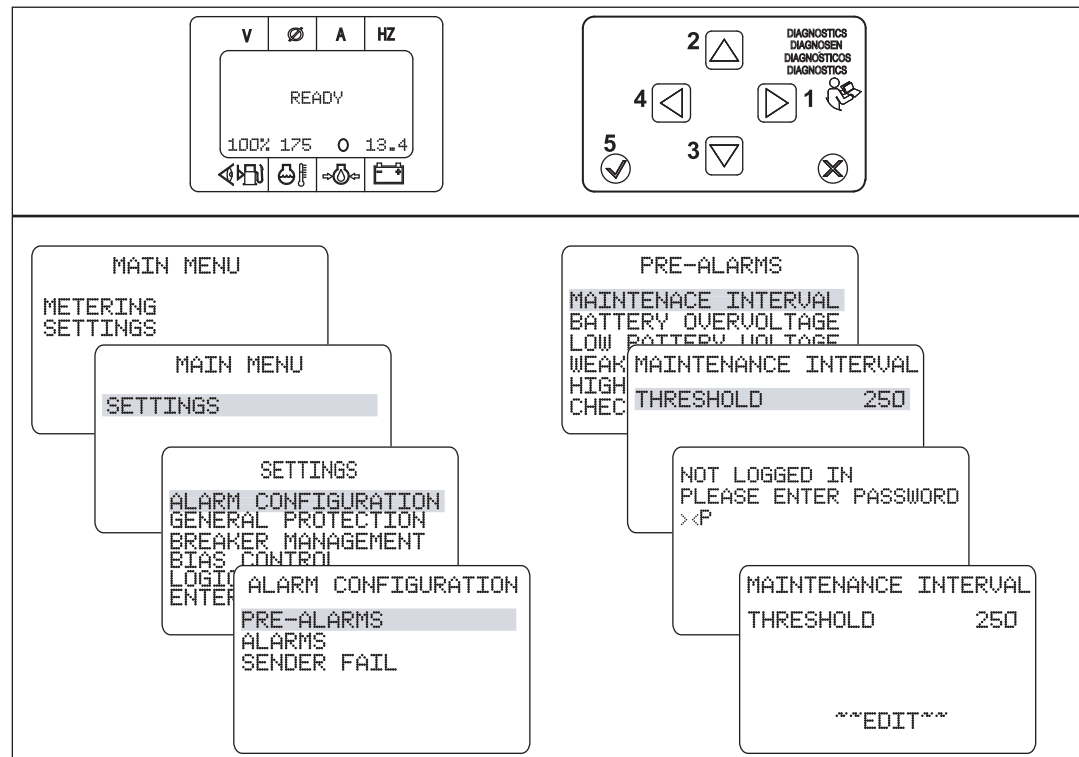

wc_gr010141

2. Using the up/down arrow buttons **(2, 3)**, highlight SETTINGS. Then, press the right arrow button.
3. Highlight ALARM CONFIGURATION. Then, press the right arrow button.
4. Highlight PRE-ALARMS. Then, press the right arrow button.

This procedure continues on the next page.

Continued from the previous page.

5. Highlight the MAINTENANCE INTERVAL. Then, press the right arrow button.
6. Highlight the THRESHOLD. Then, press the check mark button **(5)**.
7. If you are not logged in, enter the password "OP". Press the check mark button.
8. Using the up/down arrow buttons, change the value as desired. Press the check mark button when finished.
9. Exit by pressing the left arrow button **(4)** three times or until the LCD displays the SETTINGS menu. Then, scroll to LOGOUT and press the check mark button. Press the left arrow button so that the READY screen appears.

8.15 Resetting the Maintenance Interval Pre-Alarm

- Requirements**
- Machine stopped
 - Start switch in REMOTE START

Note: Internal programming of the generator controller, or closed connections to a remote start switch, may cause the machine to start unexpectedly. Be prepared for the engine to start even with the engine start switch in the REMOTE START position.

Background When the MAINT INTERVAL pre-alarm is active, the PRE-ALARM ACTIVE screen is displayed and the red LED flashes.

The maintenance interval pre-alarm may be reset by using either of two different methods: 1) by holding the “X” reset button while the MAINT INTERVAL pre-alarm screen is being displayed, or 2) through the METERING menu. Both methods are described below.

Procedure Perform the procedure below to reset the maintenance interval pre-alarm.

1. With the PRE-ALARM ACTIVE screen showing, press and hold the “X” reset button (6) for 10–20 seconds. This will clear the pre-alarm and reset the maintenance interval timer back to 250 (or the value it is currently set to).

If that method is unsuccessful, continue.

2. Press the right arrow button (1) to access the PRE-ALARMS menu.

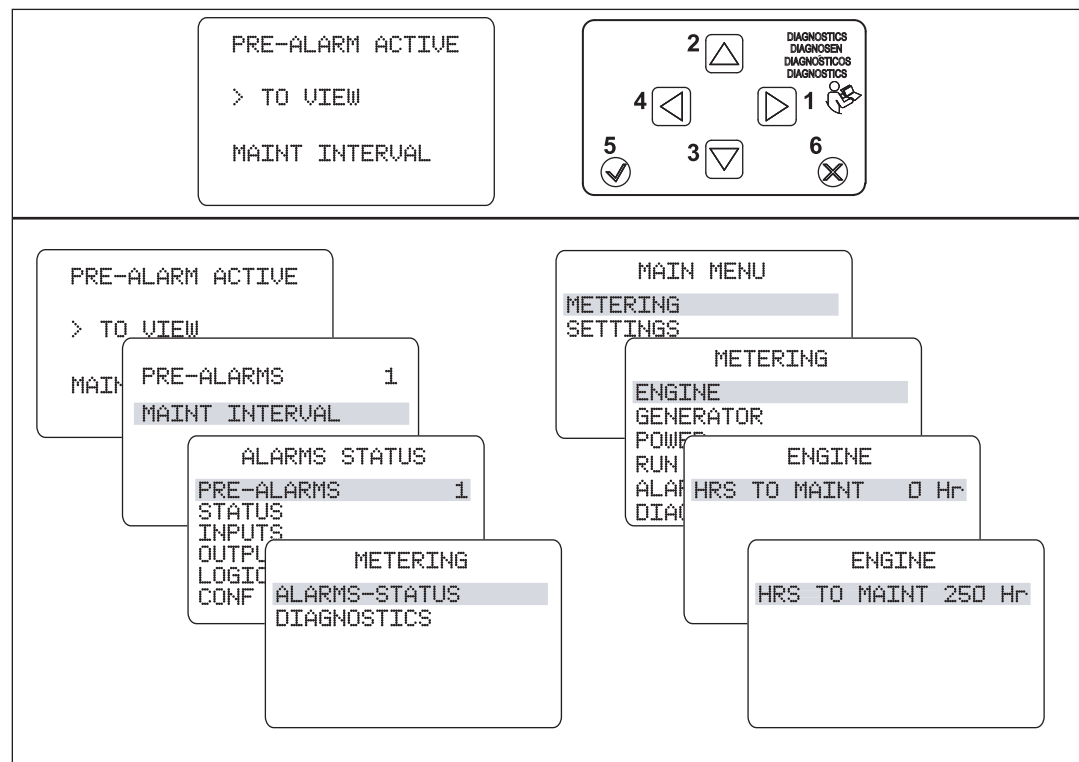

wc_gr010142

This procedure continues on the next page.

Continued from the previous page.

3. With the PRE-ALARMS screen showing (MAINT INTERVAL highlighted), press the left arrow button **(4)** three times.
4. Using the up/down arrow buttons highlight METERING. Then, press the right arrow button.
5. Using the up/down arrow buttons highlight ENGINE. Then, press the right arrow button.
6. Highlight HRS TO MAINT. Then, press and hold the “X” reset button for 10–20 seconds. This will clear the pre-alarm and reset the maintenance interval timer back to 250 (or the value it is currently set to).
7. Exit by repeatedly pressing the left arrow button until the READY screen appears.

8.16 Resetting a Loss of Voltage Pre-Alarm

Background The loss of voltage pre-alarm condition occurs most often because of an open lug door switch. During a loss of voltage pre-alarm, the LCD will display the screens below.

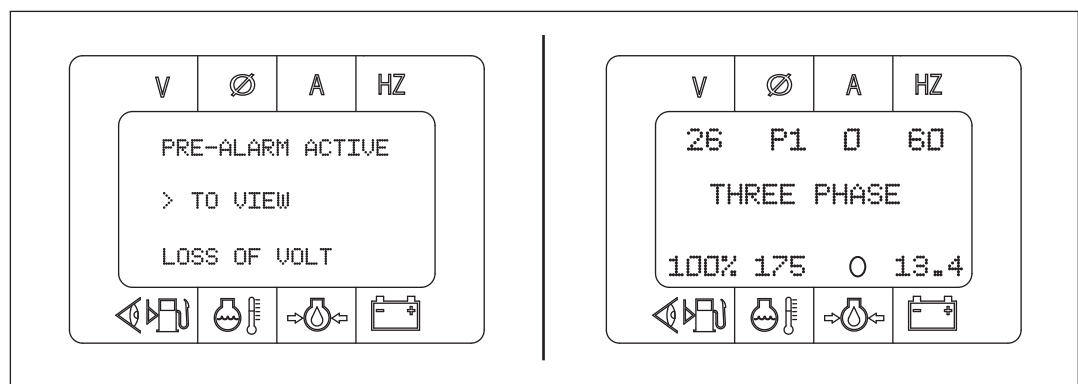

wc_gr010179

To reset the loss of voltage pre-alarm, simply close the lug door. If the voltage does not return to normal, further troubleshooting will be needed.

Note: *The loss of voltage pre-alarm will only occur when the voltage selector switch is in the 120/240 position. The condition will still exist if in a 3-phase mode, but the pre-alarm will not activate.*

8.17 Accessing and Using the Event Log

- Requirements**
- Machine stopped
 - Start switch in REMOTE START

Note: Internal programming of the generator controller, or closed connections to a remote start switch, may cause the machine to start unexpectedly. Be prepared for the engine to start even with the engine start switch in the REMOTE START position.

Background

The event log allows the technician to review recent events of the machine including pre-alarm and alarm (shut-down) conditions. The event log can aid the technician in diagnosing machine problems.

Note: Before accessing the event log, check the date and time of the generator controller. The date and times listed in the event log will be relative to the date and time setting of the generator controller.

Procedure

Perform the procedure below to access the event log.

1. At the READY screen, press the right arrow button to bring up the MAIN menu.
2. Highlight METERING. Then, press the right arrow button.
3. Highlight ALARMS-STATUS. Then, press the right arrow button.
4. Highlight EVENT LOG. Then, press the right arrow button.

The LCD displays the events of the event log. Events with the suffix "A" are alarm conditions. Events with the suffix "P" are pre-alarm conditions. The events are:

LCD Screen	Meaning
OVERCRANK A	Overcrank pre-alarm
ENGINE RUNNING	Engine running
PROT SHUTDOWN	Protective shutdown
EMERGENCY STOP A	Emergency stop alarm
ATS INPUT CLOSED	Automatic transfer switch input closed
NORM SHUTDOWN	Normal shutdown
FUEL LEVEL SENDR FAIL P	Fuel level sender failure pre-alarm
FUEL LEVEL SENDR FAIL A	Fuel level sender failure alarm
LOW FUEL LEVEL P	Low fuel level pre-alarm
LOW FUEL LEVEL A	Low fuel level alarm
OVER VOLTAGE P	Over voltage pre-alarm
OVER CURRENT P	Over current pre-alarm
LOW OIL PRES A	Low oil pressure alarm
LOSS OF VOLT P	Loss of voltage pre-alarm
LOSS OF VOLT	Loss of voltage
LOW OIL PRES P	Low oil pressure pre-alarm
LOW BATT VOLT P	Low battery voltage pre-alarm
OIL SNDR FAIL P	Oil sender failure pre-alarm
OIL SNDR FAIL	Oil sender failure

LCD Screen	Meaning
GEN TEST LOADED	Generator test loaded
MAINT INTERVAL P	Maintenance interval pre-alarm
LOW COOL LEVEL A	Low coolant level alarm

5. Highlight the event of interest. Then, press the right arrow button.

Details of the event appear: They are:

- ACTIVE
- OCCURENCE COUNT
- FIRST DATE
- FIRST TIME
- LAST DATE
- LAST TIME
- FIRST ENG HRS
- LAST ENG HRS
- DETAILS

Most recent event

To find the alarm event that has occurred most recently:

1. Scroll to each alarm event and record the time it occurred.
2. Compare the dates and times of all alarm events. The one with the most current date and time is the most recent.

9 Operation—Deep Sea Controller

9.1 Main Circuit Breaker

Location Various styles of main circuit breakers may be found on Wacker Neuson Mobile generators. The main circuit breaker (a) is located on the control panel.

Note: *Graphic is representative only. Your machine may vary.*

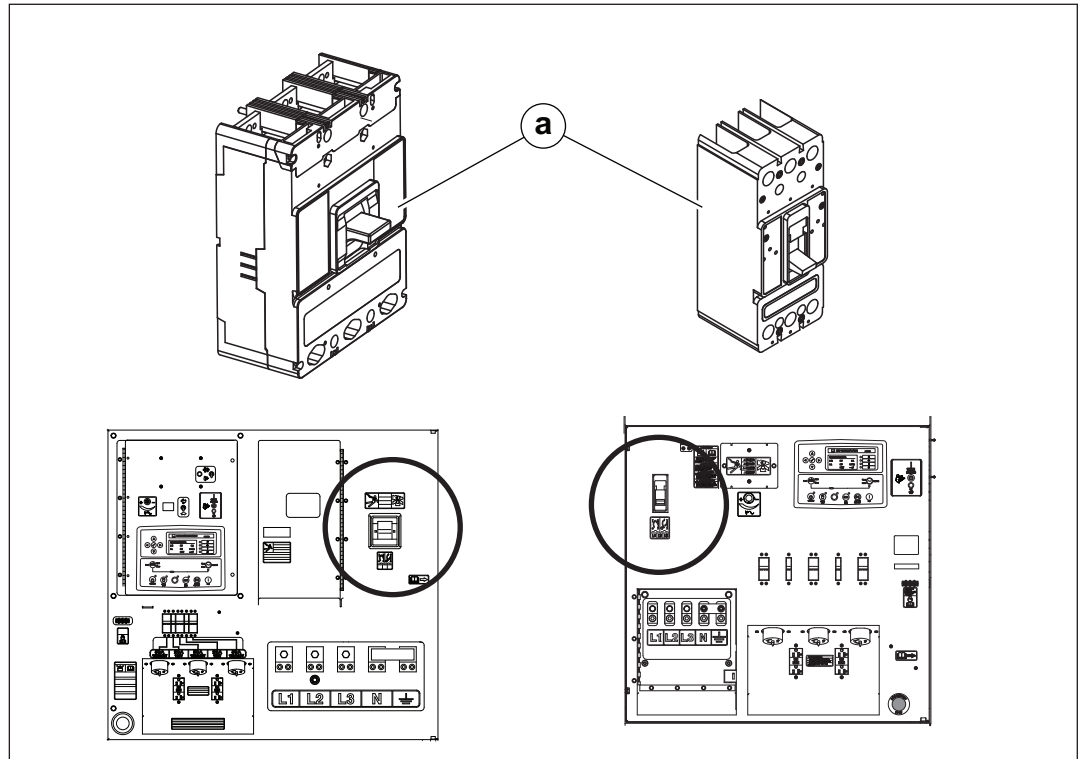

wc_gr011444

- Functions**
- The main circuit breaker interrupts power from the voltage selector switch to the terminal lugs.
 - The main circuit breaker **does not** interrupt power to the convenience receptacles.



WARNING

Electric shock hazard. High voltage is present inside the control panel while the engine is running.

- ▶ Do not open the control panel unless the engine is stopped.

NOTICE: Before shutting down the generator or performing any service to the generator, make sure the main circuit breaker is in the OFF position.

9.2 Generator Controller Power Switch

Description The generator controller power switch (a) is a two-position switch: ON and OFF.

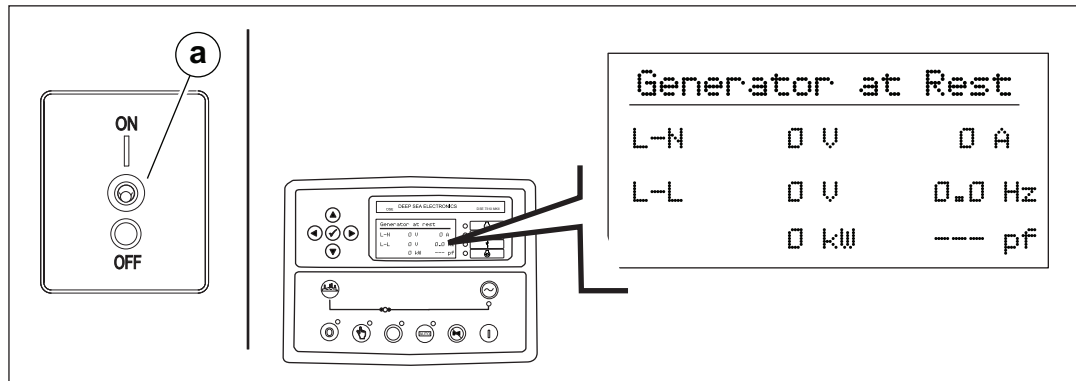

wc_gr014855

Function

Position	Function	LCD Screen
ON	When set to this position: <ul style="list-style-type: none"> Power is supplied to the generator controller. The generator controller boots up and sets itself to the Stop/Reset mode—the engine is ready to be started. 	“Generator at Rest” followed by the status screens that scroll.
OFF	When set to this position, power to the generator controller is disconnected.	Blank screen (off)

9.3 Function of the Crankcase Pressure Switch (if equipped)

Function The crankcase pressure switch is a normally closed (NC) switch. Its purpose is to keep the engine from damage due to high pressure build-up inside the crankcase. If the vent hose becomes clogged because of ice forming inside of it, pressure builds within the crankcase. This pressure could damage the engine. The crankcase pressure switch prevents damage to the engine by shutting down the engine in the event of high pressure.

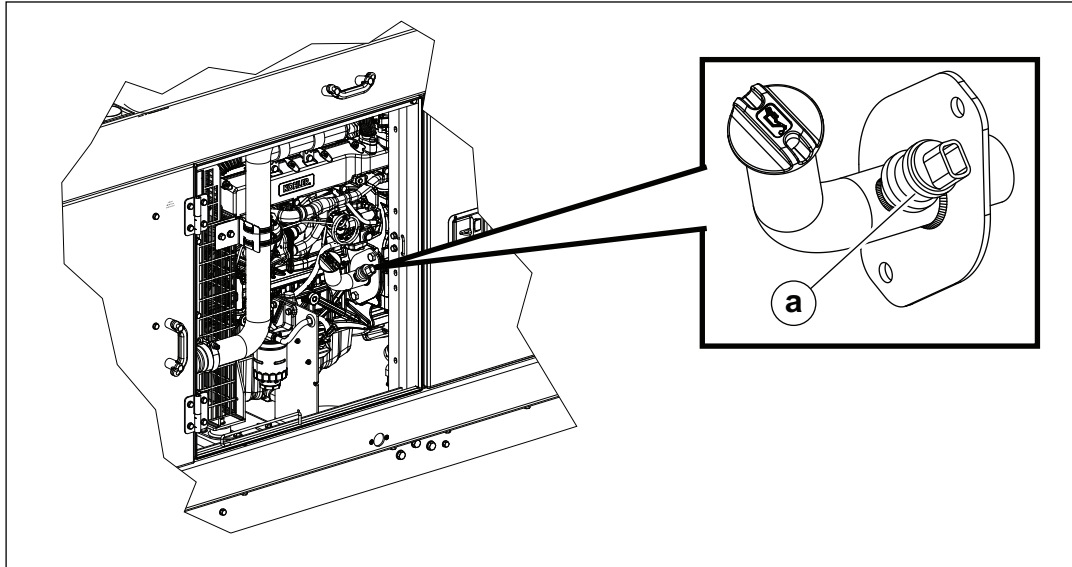

wc_gr015060

Operation

When the crankcase pressure switch **(a)** senses high pressure (>5 psi):

- the crankcase pressure switch opens which informs the controller a high pressure condition exists
- the controller sends a shut down message to the engine
- the machine shuts down
- the message “Crankcase Pressure High” appears on the controller’s LCD display

This procedure continues on the next page.

Continued from the previous page.

Procedure To rectify the condition, clear the vent hose of all obstructions.

1. Remove the insulation that covers the hose.

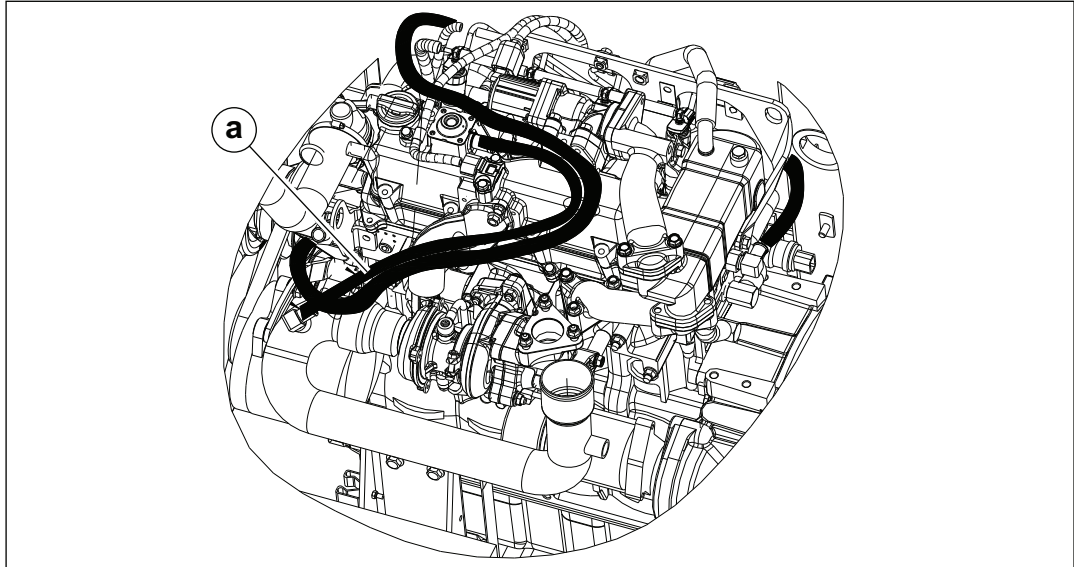

wc_gr013039

2. Remove the vent hose (a).
3. Thaw and drain the vent hose.
4. Clean the vent hose.
5. Reinstall the vent hose.
6. Reinstall the insulation.

9.4 Selecting the Voltage

Location One of two types of voltage selector switch—either three-position **(a)** or four-position **(b)**—is mounted to the machine near the lugs.

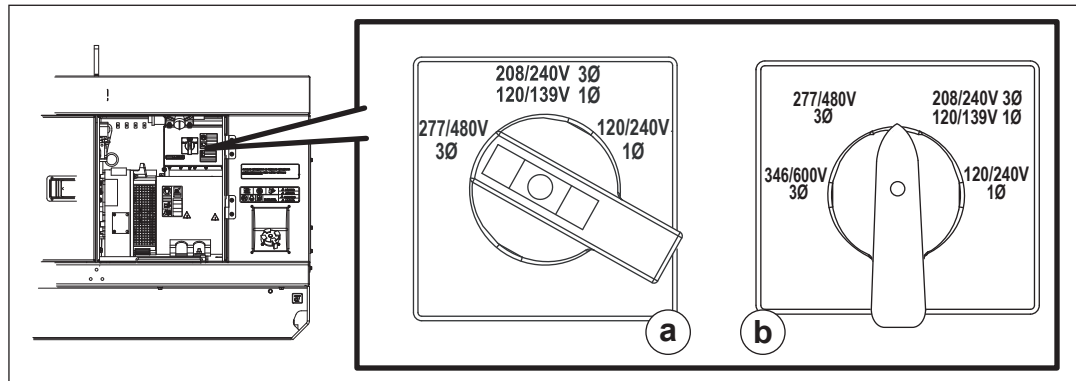

wc_gr011503



WARNING

Electric shock hazard. High voltage is present inside the voltage selector switch enclosure when the engine is running.

- ▶ Do not open the voltage selector switch enclosure unless the engine is stopped.

Selecting the voltage

The chart below lists the ranges of voltages available in each of the switch positions. Select the desired voltage by rotating the handle of the voltage selector switch. Then, use the voltage adjustment rheostat to set the exact voltage you require. The voltage is displayed on the LCD panel.

Switch position	Range of Voltages Available					
	3Ø at lugs (L-L-L)	1Ø at lugs (L-N)	1Ø at lugs (L-L)	1Ø at twist lock		1Ø at GFCI
				L-N (120V)	L-L (240V)	
120/240 VAC 1Ø	—	110–125	220–250	110–125	220–250	110–125
208/240 VAC 3Ø 120/139 VAC 1Ø	190–240	110–139	190–240	110–139	190–240	110–139
277/480 VAC 3Ø	380–480	220–277 ²	190–240 ²	110–139 ²	190–240 ²	110–139 ²
346/600 VAC 3Ø ¹	540–600	—	—	—	—	—

¹ Not available on all models.

² Not available on 600V models.

NOTICE: Do not change the position of the voltage selector switch while the engine is running. Doing so can cause arcing that can damage the voltage selector switch and the generator windings.

This procedure continues on the next page.

Continued from the previous page.

Using the rheostat

The voltage adjustment rheostat (c) is used to fine-tune the voltage as needed while the machine is running.

Note: For 600V machines, before starting the machine with the voltage selector switch in the 346/600 VAC 3Ø mode, change the voltage adjustment rheostat to the desired voltage output ($\geq 540V$). If not correctly adjusted before starting the machine, the controller may turn on the wrong voltage protection settings and shut down.

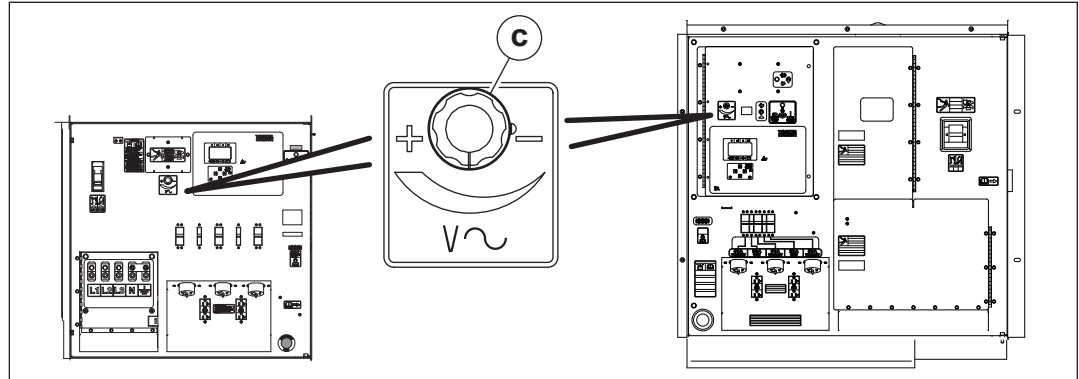

wc_gr011502

Care must be taken when using the voltage adjustment rheostat because adjusting the voltage for 3-phase operation affects the voltage available at the single-phase outlets. As the 3-phase voltage increases, so does the single-phase voltage.

NOTICE: Do not use the GFCI or twist-lock receptacle (120V) when the 1Ø voltage is above 135V. Damage to the receptacle and the tools connected to it may occur.

Switch Position	3Ø Voltage (L-L-L)	Corresponding 1Ø voltage		
		Twist lock receptacle		120V GFCI
		L-L (240V)	L-N (120V)	
208 VAC 3Ø 120 VAC 1Ø	208	208	120	120
	220	220	125	125
	240	240	139 ¹	139 ¹
277/480 VAC 3Ø	480	240	139 ¹	139 ¹
	460	230	133 ²	133 ²
346/600 VAC 3Ø ³	600	—		
	540			

¹ Do not use receptacle with this voltage.

² Voltage may be too high for some tools and equipment. Check tool/equipment specifications.

³ Not available on all models.

9.5 Wet Stacking

Overview Wet stacking is the buildup of unburned diesel fuel, moisture, and carbon particles in the exhaust system of the machine. This occurs when diesel fuel is not completely burned off during use, and a black, oily residue accumulates in the exhaust system due to operating the machine at a light load for extended periods of time.

Wet stacking can lead to reduced engine performance, pollution, premature engine wear, and permanent engine damage.

-
- Prevention**
- Use the right sized generator for the needs of the job.
 - Follow the maintenance schedule.
 - Load the machine greater than 30% of the engine rating.
 - Run the machine a few minutes per week at the operational temperature.
 - Have the machine regularly serviced by an experienced service technician.

-
- Solution**
- Have the machine serviced by an experienced service technician.
 - Operate the machine at a load of about 75–80% of the machine's nameplate rating for a few hours to raise the exhaust temperature high enough to clean out the exhaust system.

9.6 Deep Sea Controller Buttons/Functions

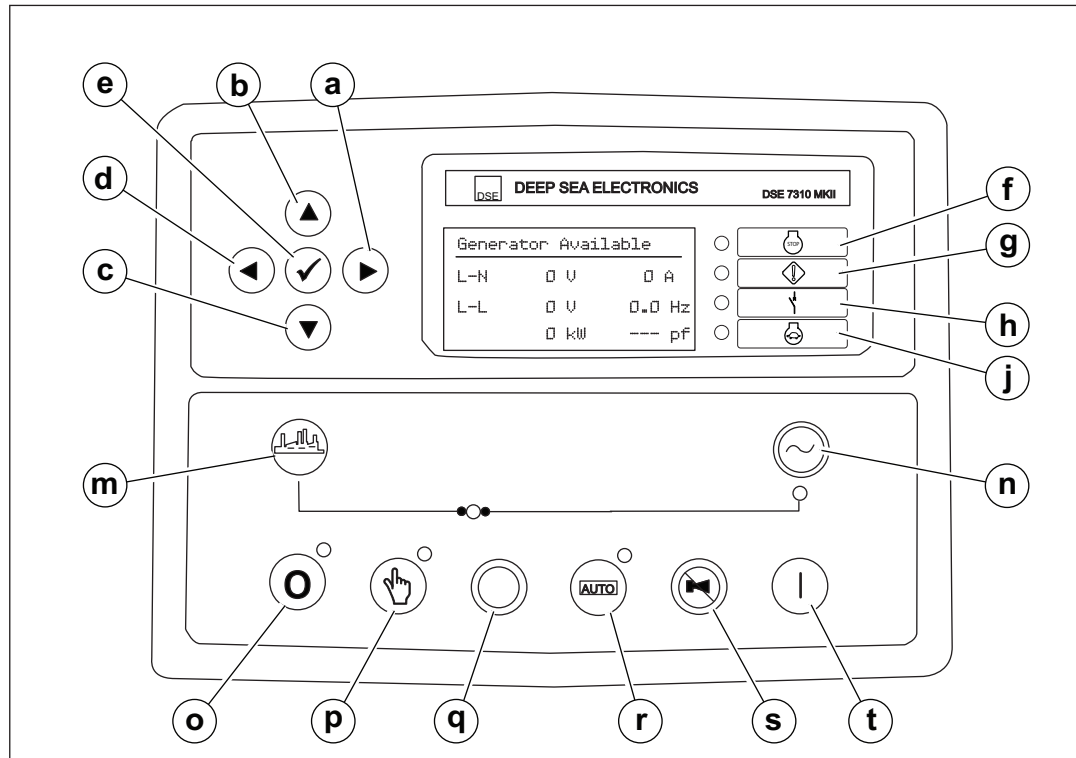

wc_gr014856

Ref.	Button/function
a	Right arrow button (right / forward)
b	Up arrow button
c	Down arrow button
d	Left arrow button (left / backward)
e	Check mark button (enter / accept) This button is used when navigating through the generator controller menus. Press this button to accept a new value or menu item.
f	Alarm indicator Illuminates during a fault condition that has stopped the engine.
g	Warning indicator Illuminates during a non-critical alarm condition. Note: non critical alarm conditions may lead to shut-down conditions.
h	Main breaker open indicator Illuminates whenever the main circuit breaker is open.
j	Low speed active indicator Illuminates when the engine idle speed is set to low idle (if equipped).
m	Load button (not used)
n	Gen-Set button (not used)

Ref.	Button/function
o	<p>Stop / Reset</p> <p>Pressing this button:</p> <ul style="list-style-type: none"> ■ Sets the generator controller into its Stop/Reset mode ■ Clears any alarm conditions for which the triggering criteria have been rectified.
p	<p>Manual mode</p> <p>Pressing this button:</p> <ul style="list-style-type: none"> ■ Sets the generator controller to the Manual mode <p>In Manual mode, the generator can be started and operated.</p>
q	(not used)
r	<p>Auto mode</p> <p>Pressing this button:</p> <ul style="list-style-type: none"> ■ Sets the generator controller to the Auto mode <p>In Auto mode, the generator can only be started and operated by a remote switch.</p>
s	<p>Lamp test / horn reset</p> <p>Pressing this button:</p> <ul style="list-style-type: none"> ■ Silences the audible alarm ■ Illuminates all of the LEDs as a lamp test feature (push and hold to perform test)
t	<p>Start</p> <p>Pressing this button in Manual mode:</p> <ul style="list-style-type: none"> ■ Starts the engine <p>Pressing this button in Stop/Reset mode:</p> <ul style="list-style-type: none"> ■ Provides a keyswitch to the engine ECU for 10 minutes

9.7 Generator Controller Alarms and Shut-Down Conditions

Background The generator controller monitors variables of engine and machine function. The generator controller has two types of alarms: warning alarms and shut-down alarms. The generator controller also monitors for electrical trip conditions.

Warning alarms

Warnings are non-critical alarm conditions that do not affect the operation of the generator system. They serve to draw the operator’s attention to an undesirable condition. Warning alarms are self-resetting when the fault condition is removed.

Warning alarms include:

- Low fuel level
- High coolant temperature
- Low oil pressure
- Time to maintenance

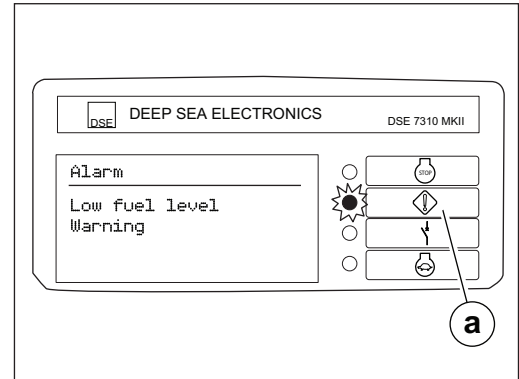

wc_gr014857

During a warning alarm condition, the LCD panel displays the type of warning alarm, the warning LED (a) illuminates, and an audible alarm sounds. The machine is not shut down. Press the “Horn Reset” button to silence the audible alarm.

Shut-down alarms

Shut-down alarms are latching alarms and stop the generator. Shut-down alarms include:

- High coolant temperature
- Low oil pressure
- Overspeed/Underspeed
- Overcrank
- Low coolant level (if equipped)
- Overcurrent
- Auto-sense fail

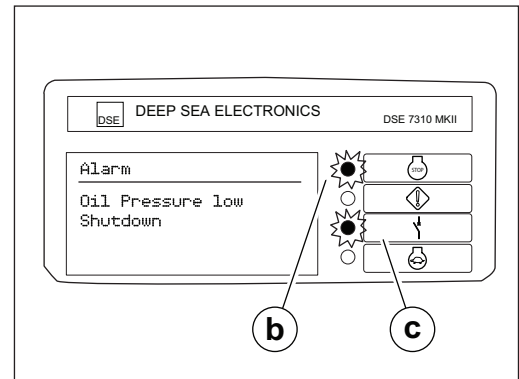

wc_gr014858

During a shut-down alarm condition, the LCD panel displays the type of alarm, the LEDs (b, c) illuminate, an audible alarm sounds, and the machine is shut down. Press the “Horn Reset” button to silence the audible alarm. Remove the fault condition, then press “Stop/Reset”.

This procedure continues on the next page.

Continued from the previous page.

Variable	Normal	Warning	Shutdown	To Reset
Fuel level	>15%	15%	—	Fill fuel tank. Press “Stop/Reset”.
Coolant temp.	85°C ±8	105°C	115°C	Add coolant. Press “Stop/Reset”.
Oil pressure	60–80 psi	20 psi	15 psi	Add engine oil. Press “Stop/Reset”.
Overspeed	60 Hz	—	66 Hz	Press “Stop/Reset”.
Underspeed	60 Hz	—	54 Hz	Press “Stop/Reset”.
Overcrank	—	—	After 3 attempts	Press “Stop/Reset”.
Time to maintain	500 hours	0 hours	—	Reset generator controller.
Coolant level	Above sender	—	Below sender	Add coolant. Press “Stop/Reset”.

Electrical trips Electrical trips are latching type alarms that trip the main circuit breaker. During an electrical trip, the LEDs **(b, c)** illuminate, an audible alarm sounds, and a cooldown timer starts. The engine stops when the timer reaches 0.

These electrical trips are often, though not always, electrical load issues that occur independent of the engine.

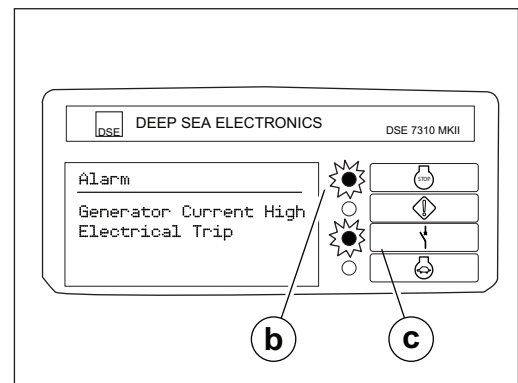

wc_gr014859

Press the “Horn Reset” button to silence the audible alarm. Remove the fault condition, then press “Stop/Reset” to enable the engine to be restarted.

9.8 Before Starting the Machine

**WARNING**

Personal injury hazard. Failure to follow the listed procedures may cause injury to personnel or damage to the generator.

- ▶ Make sure that all persons setting up the generator are certified or fully trained on the installation of the generator.

Before putting the generator into service, perform each item on the following checklist.

Exterior checks

- Check for damage that may have occurred during towing or travel to the jobsite. Repair any damage.
- Make sure that the generator is level.
- Chock the trailer wheels.

Internal checks

- Check engine oil, coolant, and fuel levels—fill as required.
- Check the fan belt and hoses on the engine for loose connections or fraying—tighten or replace belts and hoses as required.
- Remove any debris that has lodged in vents, near the radiator, or around the fan.
- Make sure the exhaust compartment is clean, with nothing touching the muffler or exhaust pipes.

Pre-operation checks

- Read and understand the engine owner's manual.
- Check local regulations and NEC standards for electrical connections.
- Determine voltage needs; obtain proper cable and equipment to meet the needs. Follow local regulations and NEC standards.
- Make sure that the generator is grounded to a good earthen ground per local regulations and NEC standards.
- Review and follow the safety instructions found in the front of this Operator's Manual.

9.9 Starting and Running the Generator



CAUTION

Possibility of injury or equipment damage. Failure to match phase, voltage, and frequency may cause equipment connected to the generator to operate incorrectly.

- ▶ When using the generator as a stand-by or substitute power supply, make sure the phase, voltage, and frequency of the generator matches that of the utility lines or of any other power source normally used.

Procedure

Perform the procedure below to start the generator.

1. Check the position of the voltage selector and make sure that it is set for the desired voltage output. Lock the voltage selector in place.
2. Set the main circuit breaker to the OFF “O” position.
3. Set the convenience receptacle circuit breakers to the OFF “O” position.
4. Set the generator controller power switch (a) to the ON “I” position.

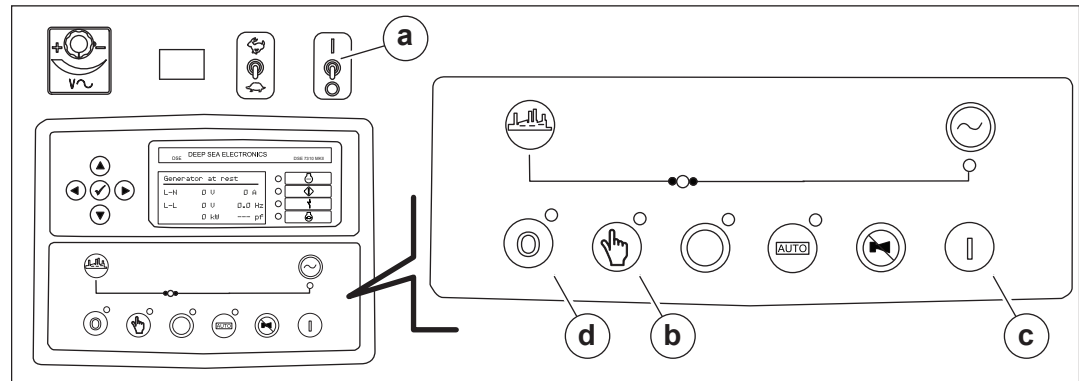

wc_gr014860

Notes

5. Verify that the lug door is closed.
 - Do not open the lug door or change the low idle switch during the first 15 seconds after the engine is started.
 - On machines equipped with a low idle switch, starting in low idle mode delays voltage configuration sensing until the machine is brought up to rated speed the first time after a start. The lug door must be closed before the low idle switch is turned off for the sensor to work correctly.
 - The lug door interlock switch does NOT interrupt power to the convenience receptacles. However, the switch does stop excitation at the generator. The result is significantly reduced voltage at the convenience receptacles.
6. Press the “Manual mode” button (b).
7. Press the “Start” “I” button (c).

This procedure continues on the next page.

Continued from the previous page.

The LCD panel displays several screens as the start-up sequence begins.

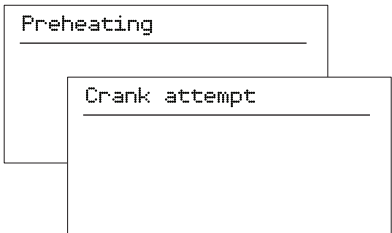
Display		Meaning / Description
	Preheating	The engine is heating.
	Crank attempt	The engine is attempting to start.

8. The engine will crank. During a normal cycle, the engine cranks for 12 seconds and rests for 12 seconds. This cycle will repeat three times.

Note: *If the engine does not start within the normal cycle, the generator controller will shut down the engine. "Failed to start" will display on the LCD.*

► To repeat the crank cycle, press the Stop/Reset "O" button (d) to reset the engine control model. Allow the starter motor to cool between start-up attempts.

9. After the engine starts, the LCD panel displays the following screens.

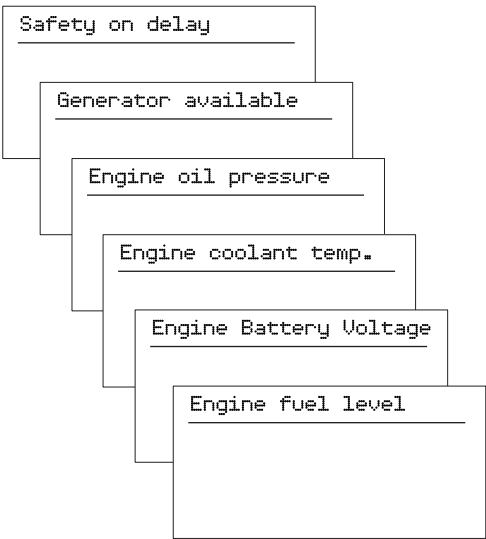
Display		Meaning / Description
	Safety on delay	The generator controller is determining system status.
	Generator available	The generator is operating and ready for service.
	Engine oil pressure	Displays the engine oil pressure.
	Engine coolant temp.	Displays engine coolant temperature.
	Engine battery voltage	Displays the battery voltage.
	Engine fuel level	Displays the percentage of remaining fuel.

10. Allow the engine to warm before closing the main circuit breaker.

This procedure continues on the next page.

Continued from the previous page.

11. Check the voltage displayed on the LCD panel. Adjust the voltage as needed using the voltage adjustment rheostat. See topic *Selecting the Voltage*.

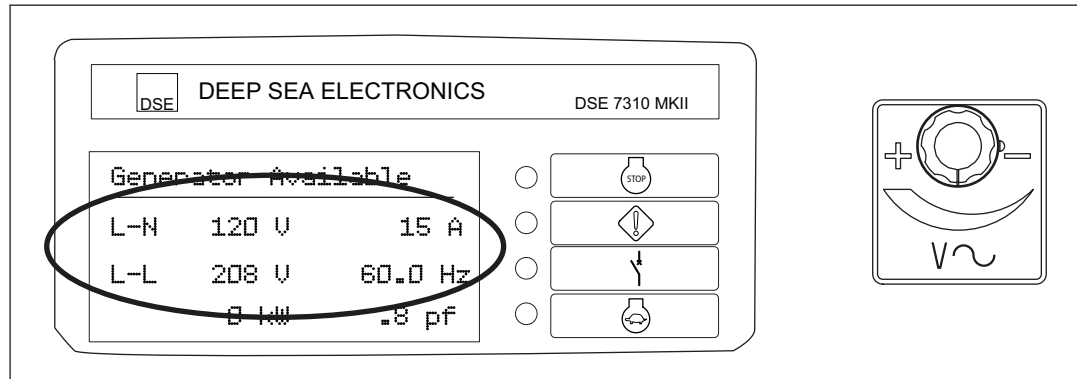

wc_gr014854

12. Turn on (close) the appropriate circuit breakers for your load.

9.10 Stopping the Generator

Requirements Before stopping the generator:

- Check with other personnel on the jobsite and let them know that power is being turned off.
- Make sure that the power shutdown will not create any hazards by turning off devices such as pumps, heaters, or lights that may need to be kept on.

Procedure

Perform the procedure below to stop the generator.

1. Remove all loads from the generator.
2. Open (set to OFF "O") the convenience circuit breakers.
3. Open (set to OFF "O") the main circuit breaker.
4. Let the engine run for a minimum of five minutes to allow it to cool down.
5. Press the Stop/Reset "O" button (a) to start the cool down/shut off timer. The engine shuts off automatically when the timer expires.

Note: To bypass the timer and shut off the engine immediately, press the Stop/Reset "O" button a second time.

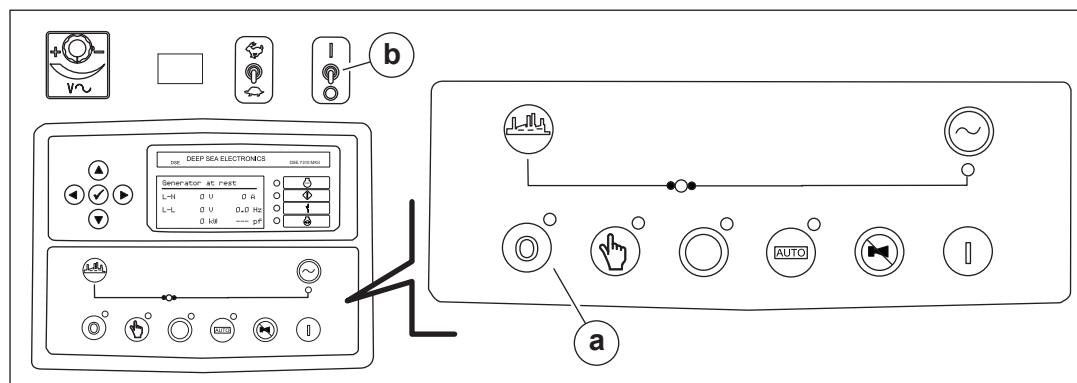

wc_gr014861

6. Set the generator controller power switch (b) to the OFF "O" position.

9.11 Emergency Stop Switch

Location The emergency stop switch is the red button **(a)** located to the left of the control panel. The button can be accessed with the panel doors closed. It is electrically isolated from the switch and also from the rest of the metering panel.

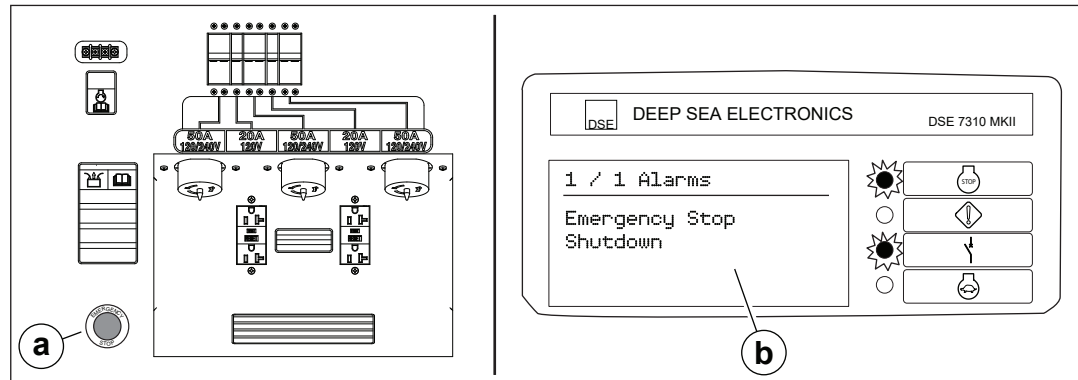

wc_gr014862

Operation Activate the emergency stop switch by pressing the red button. This results in the following actions:

- The main breaker opens.
- The “Main Breaker Open” LED illuminates.
- The engine stops.
- The LCD panel **(b)** displays a flashing “Emergency Stop” message.
- The “Alarm” LED illuminates, and an audible alarm sounds.

To silence the audible alarm, press the Horn Reset button on the keypad. The flashing message and illuminated LED will remain visible until the emergency stop switch is deactivated.

To deactivate the emergency stop switch, pull the red button out.

NOTICE: Press the emergency stop button only in the case of an actual emergency where the generator must be stopped immediately. In all other instances, open the main line circuit breaker and then press the Off button.

9.12 Engine and Generator Monitoring

Description Engine and generator information is displayed on the LCD panel and scrolls continuously while the generator is operating.

For more information on the Deep Sea controller, see chapter *Working with the Deep Sea Controller*.

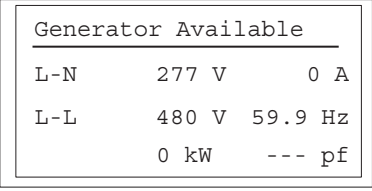
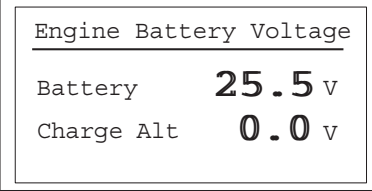
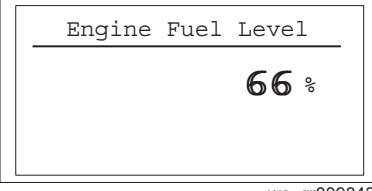
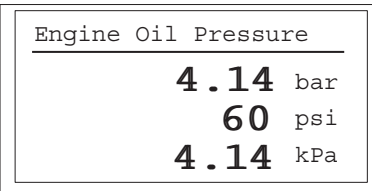
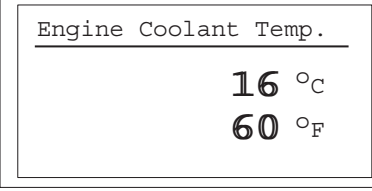
 <p>Generator Available</p> <p>L-N 277 V 0 A</p> <p>L-L 480 V 59.9 Hz</p> <p>0 kW --- pf</p> <p>wc_gr009841</p>	<p>Volts “V” - Displays the AC output voltage being produced by the generator</p> <p>Amps “A” - Displays the AC output amperage produced by the generator. If the generator is operating at no-load, output amperage will display a 0.</p> <p>Hertz “Hz” - Displays output frequency. This gauge should read approximately 60 Hz under a no-load condition. If the frequency is too high, check the engine rpm.</p>
 <p>Engine Battery Voltage</p> <p>Battery 25.5 V</p> <p>Charge Alt 0.0 V</p> <p>wc_gr009842</p>	<p>Displays the available voltage of the battery</p>
 <p>Engine Fuel Level</p> <p>66 %</p> <p>wc_gr009843</p>	<p>Displays the percentage of fuel remaining in the fuel tank</p>
 <p>Engine Oil Pressure</p> <p>4.14 bar</p> <p>60 psi</p> <p>4.14 kPa</p> <p>wc_gr009844</p>	<p>Displays the engine oil pressure (if equipped)</p>
 <p>Engine Coolant Temp.</p> <p>16 °C</p> <p>60 °F</p> <p>wc_gr009845</p>	<p>Displays the current temperature of the engine coolant</p>

10 Working with Deep Sea Controller: DSE 7310 MKII

10.1 Introduction

During normal operation, the generator controller displays current information on machine performance and operating status. The keypad (a) provides access to additional monitoring functions through a series of menus displayed on the LCD panel (b). You can also use the keypad to change certain machine settings if desired.

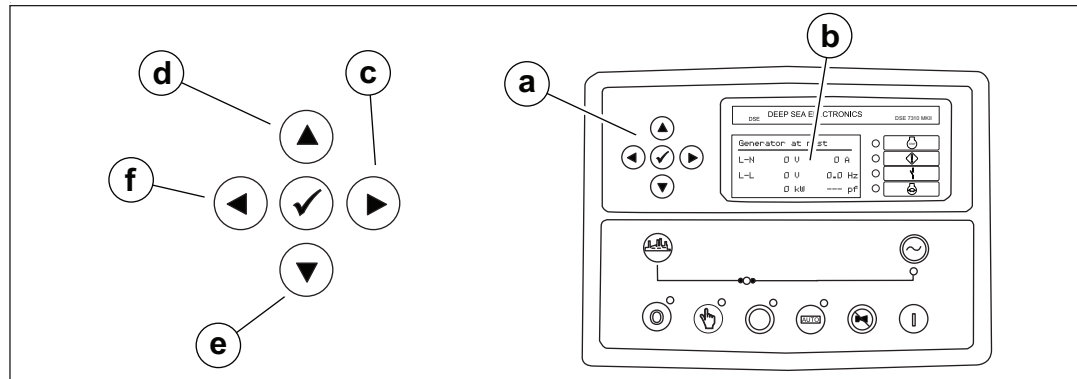

wc_gr014863

1. The various monitoring and configuration menus can be accessed by pressing the right arrow button (c).
2. To select items on a menu, use the up/down arrow buttons (d, e) to scroll through the available options.
3. To return to a previous menu screen, press the left arrow button (f).
4. To exit menu navigation and return to LCD panel monitoring status, press the left or right arrow button (f, c) to return to the "Status" page.

10.2 Navigating the Menus

The graphic below serves as a navigational aid when accessing the various menus of the generator controller. See the accompanying table for information about the menu items.

Note: *The specific order and quantity of screens may vary by model.*

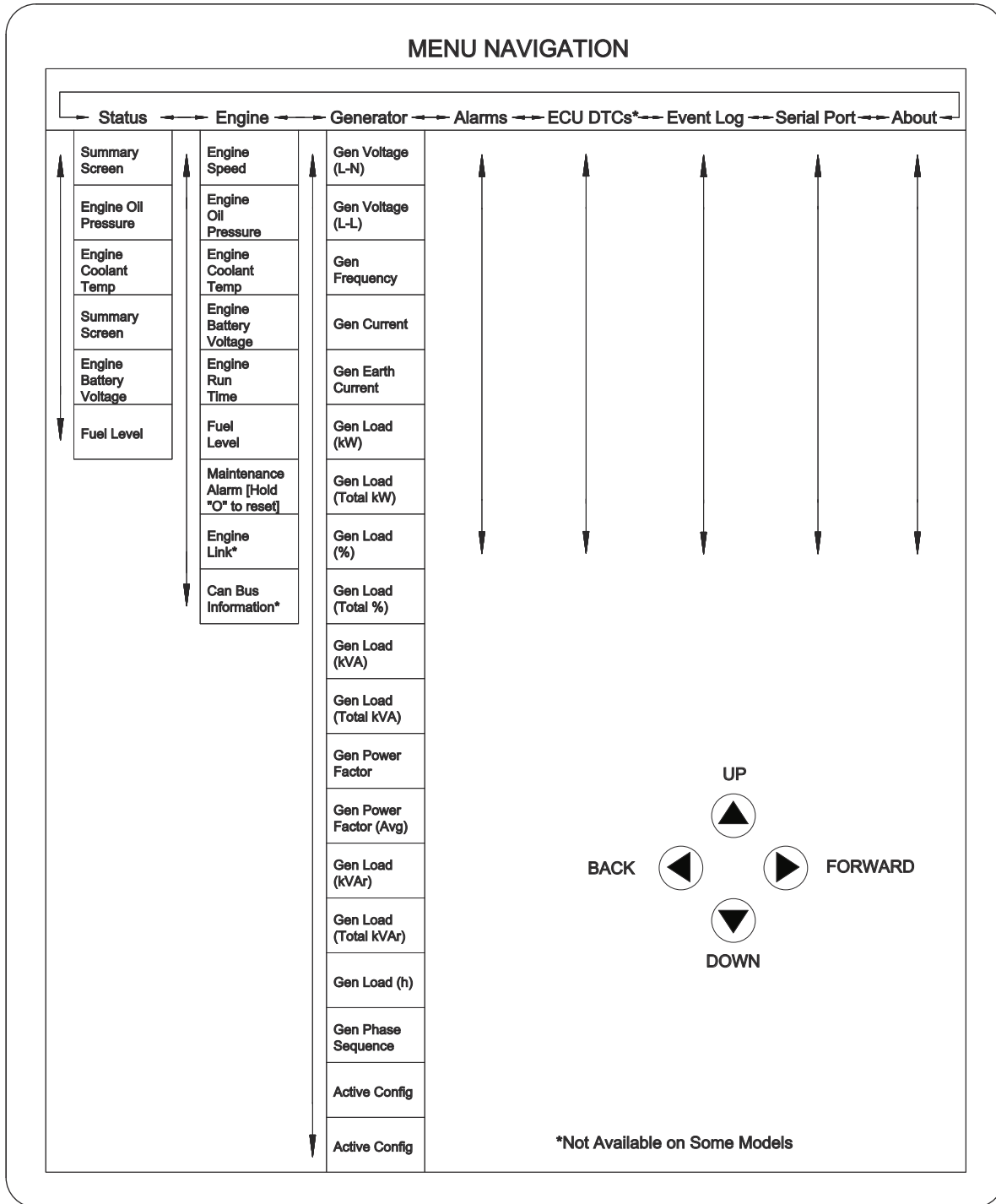

Working with Deep Sea Controller: DSE 7310 MKII

Menu Item	Description	Menu Item	Description
About	Module information	—	—
Active Config	Generator configuration	Gen Load (h)	Generator load kVArh
Alarms	Alarms active	Gen Load (%)	Generator load Percent
—	—	Gen Load (kVA)	Generator load kVA
Can Bus Information	Can Bus information	Gen Load (kVA)	Generator load kVA
—	—	Gen Load (kW)	Generator load kW
ECU DTCs	Engine Diagnostic Trouble Codes	Gen Load (Total %)	Generator load total percent
Engine	Engine info	Gen Load (Total kVA)	Generator load total kVA
Engine Battery Voltage	Battery and alternator voltage	Gen Load (Total kW)	Generator load total kW
—	—	Gen Phase Sequence	Generator phase sequence
Engine Coolant Temp	Coolant temperature in °C and °F	Gen Power Factor	Generator power factor
Engine Link	Engine link info	Gen Power Factor (Avg)	Generator average power factor
Engine Oil Pressure	Engine oil pressure in Bar, PSI, and kPa	Gen Voltage (L-L)	Generator voltage line to line
Engine Run Time	Accumulated time in hours	Gen Voltage (L-N)	Generator voltage line to neutral
Engine Speed	Engine RPM	Generator	Generator info
Event Log	List of past events	Maintenance Alarm (Hold "O" to reset)	Hours until maintenance warning
—	—	Serial Port	Serial part information
Fuel Level	Percentage of fuel remaining in the tank	Status	Status information
Gen Current	Generator current amps	Summary Screen	Main summary screen
Gen Earth Current	Generator earth current amps	—	—
Gen Frequency	Generator frequency (Hz)	—	—

Working with Deep Sea Controller: DSE 7310 MKII

10.3 Adjusting Screen Contrast

Overview The contrast of the LCD display can be adjusted to suit the operator's preference.

Procedure Perform the procedure below to adjust the screen contrast.

1. Access the "Editor—Display" menu on the LCD panel (**a**) by pressing and holding the check mark button (**b**) on the keypad.

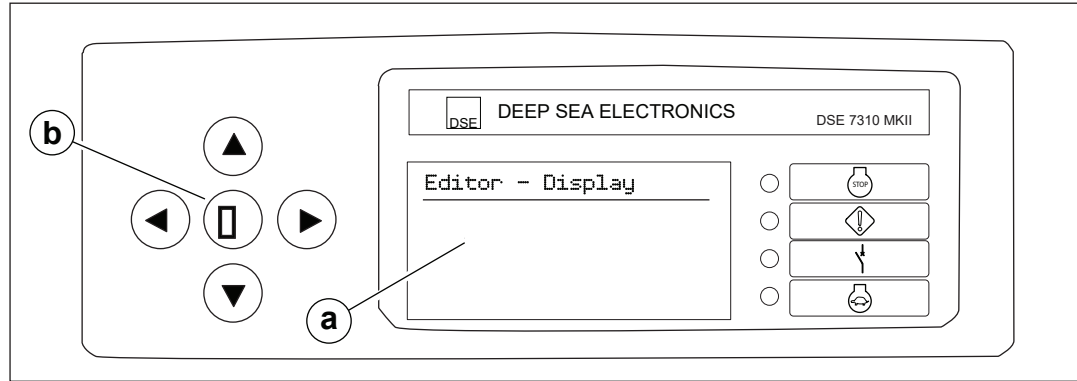

wc_gr014864

2. Wait a few seconds for the "Contrast" screen to appear, or use up/down arrow buttons to navigate to the "Contrast" screen. Then, press the check mark button. The contrast value will start flashing.

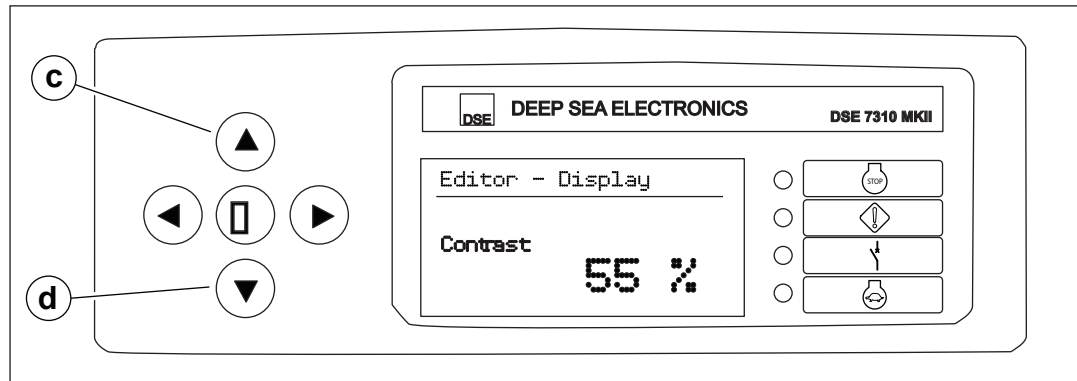

wc_gr014865

3. Press the up/down arrow buttons (**c, d**) to change the contrast percentage as desired. When the screen contrast reaches a comfortable viewing level, press the check mark button to accept the choice.
4. Exit by pressing and holding the check mark button until the generator controller returns to the "Status" screen.

10.4 How to Reset the Maintenance Timer

Background The maintenance timer is preset to 500 hours. When the maintenance timer times out, the generator controller sounds the audible alarm.

Procedure Perform the procedure below to reset the maintenance timer.

1. From the “Status” menu, press the right arrow button to reach the “Engine” menu.

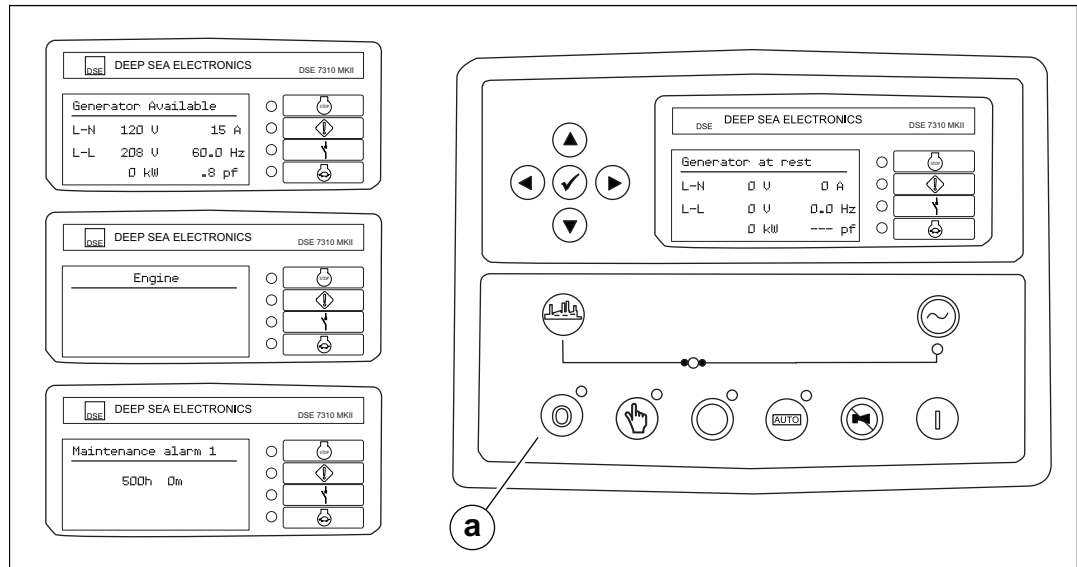

wc_gr014866

2. Using the up and down arrow buttons, navigate to the “Maintenance alarm 1” screen.
3. Press the “Stop/Reset” button (a). The timer will return to 500 hours.

11 How to Connect Loads—480V

The information in this chapter on how to connect loads applies to machines with maximum capabilities of up to 480V.

This chapter does not apply to machines with maximum capabilities of up to 600V.

11.1 Lug Terminal Connection Diagrams

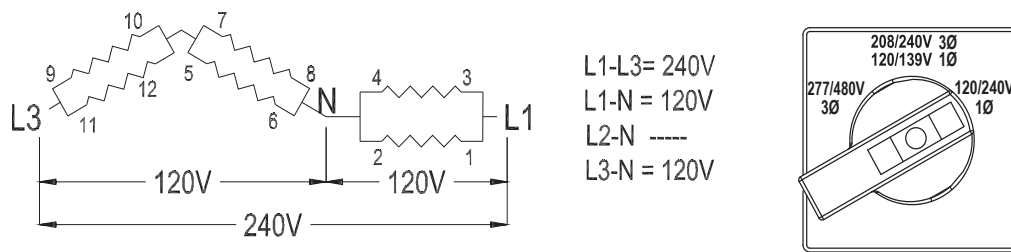
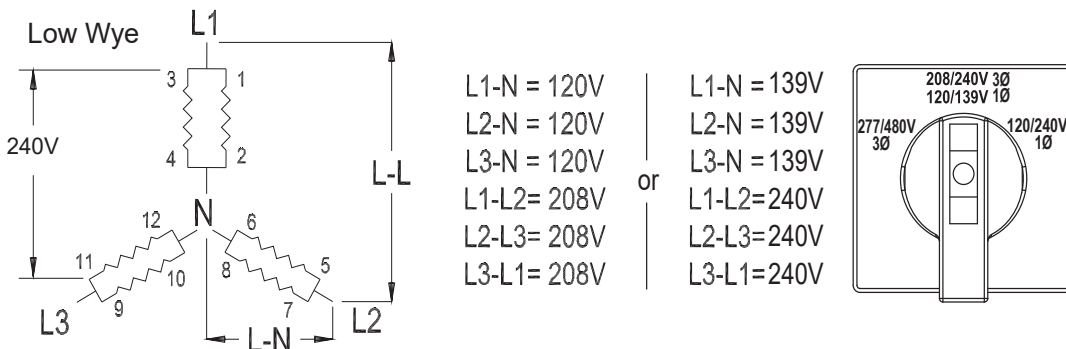
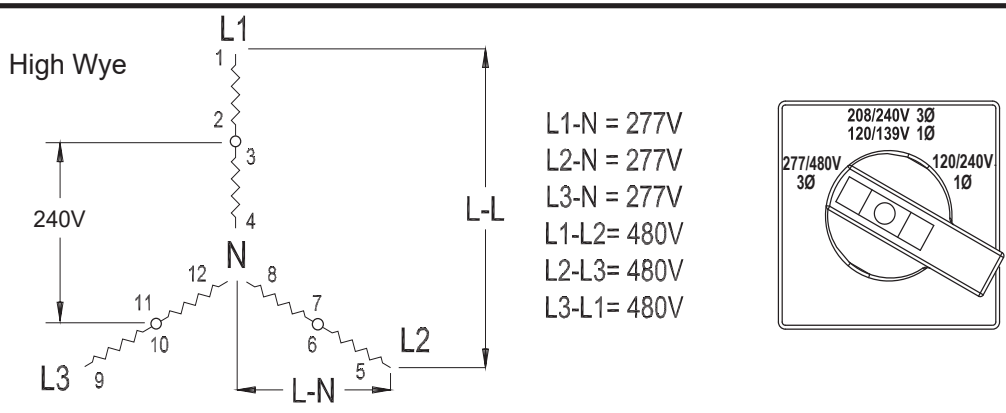
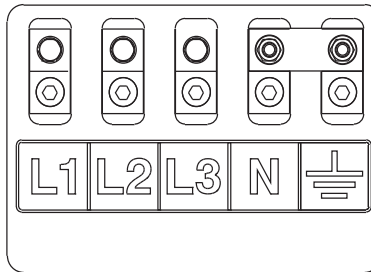

wc_gr010197

11.2 Best Practices for Balancing Loads



WARNING

Electric shock hazard. High voltage can cause serious injury or death.

- Connections must be made by a qualified electrician.

Background

Three-phase (3Ø) loads are, by their nature, balanced. It is when single-phase (1Ø) loads are combined with existing 3Ø loads that an unbalanced condition can occur. Dedicated 1Ø loads may also be unbalanced if the loads are not equally distributed between the legs (L1 and L3) of the generator.

The sensing wires of the generator’s voltage regulator are connected to L1 and L3. Having the loads balanced between L1 and L3 allows the generator to provide voltage that is more consistent with the voltage needs of the equipment connected to it.

1Ø Situations

For 1Ø situations (voltage selector switch in the 208/240V position)

Unbalanced loads can be detected by observing the generator controller LCD panel. If an unbalanced load condition exists, there will be a significant difference (over 10%) in both voltage and amperage between the legs.

Observe the amp draw on L1 and L3.

Note: *Basler controller screens are shown. For Deep Sea controller machines, see chapter Working with Deep Sea Controller: DSE 7310 MKII for the corresponding parameters.*

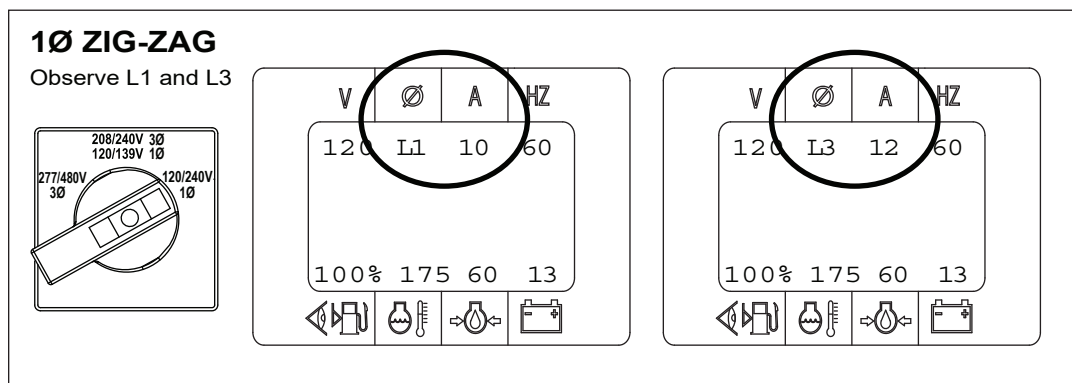

wc_gr011280-480V

If an unbalanced load condition is detected, stop the engine and reconnect the loads so that loads (amp draw) are more equally distributed between the legs (L1 and L3)—for example, if a heavy load and a light load are connected to L1, but only a light load is connected to L3. Reconnect the loads so that the heavy load is connected to L1, and the two lighter loads are connected to L3. Redistributing the loads will equalize the voltage for each leg and allow for better performance from the equipment connected to the generator.

Reconnect the loads as necessary to provide the most equal amp draw between L1 and L3.

This procedure continues on the next page.

Continued from the previous page.

3Ø Situations When combining 1Ø loads with 3Ø loads (voltage selector switch in 208/240V position), unbalanced loads can be detected by observing the generator controller LCD panel. If an unbalanced load condition exists, there will be a significant difference in both voltage and amperage between the phases.

Observe the amp draw on P1, P2, and P3.

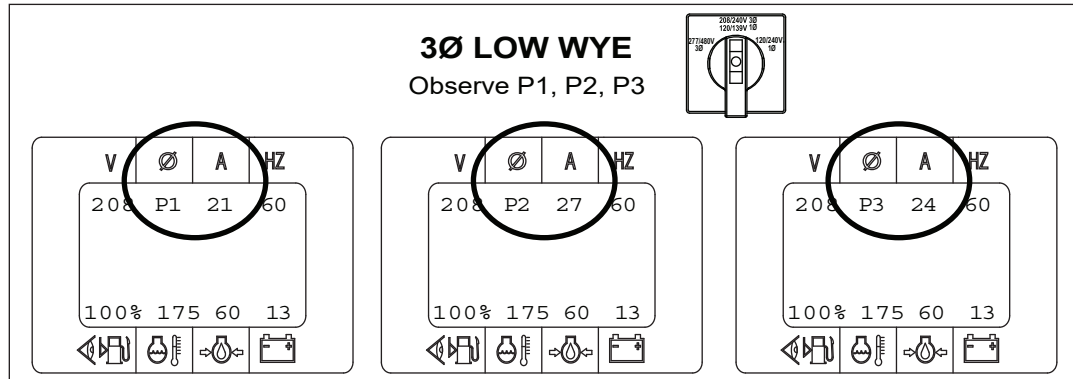

wc_gr011281-480V

If an unbalanced load is detected, stop the engine and reconnect the loads so that loads (amp draw) are more equally distributed. This will also help equalize the voltage for each phase.

When connecting multiple 120V 1Ø loads to the lugs while in 208/240V 3Ø mode, use L1 as “hot” for the first load (or heaviest load). Use L3 as “hot” for the second load (or next heaviest load), and use L2 as “hot” for the third load (lightest load). If additional loads are to be connected, repeat the connection sequence L1, L3, and then L2.

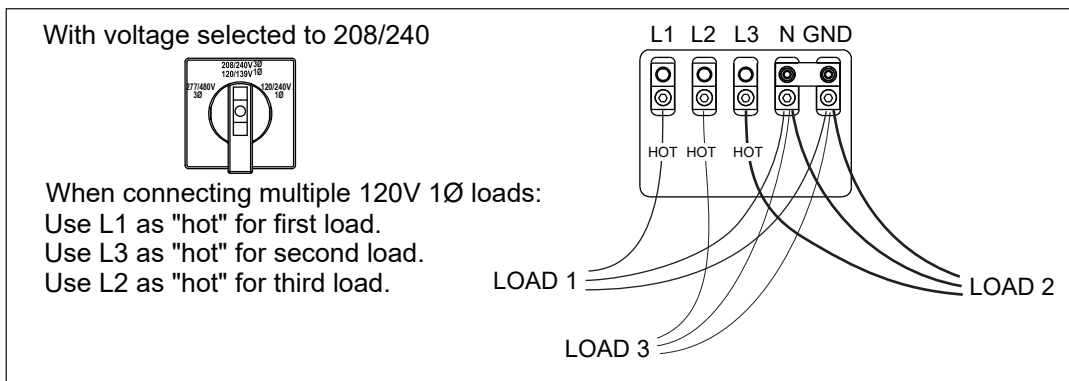

wc_gr011282-480V

This procedure continues on the next page.

Continued from the previous page.

Using the receptacles

This information applies whether the machine is running in 3Ø or in 1Ø.

When connecting two loads to the duplex receptacles, instead of plugging both loads in to the same duplex receptacle, plug the first load in to one of the duplex receptacles. Then, plug the second load in to the other duplex receptacle. Additional loads can be plugged in to either duplex receptacle.

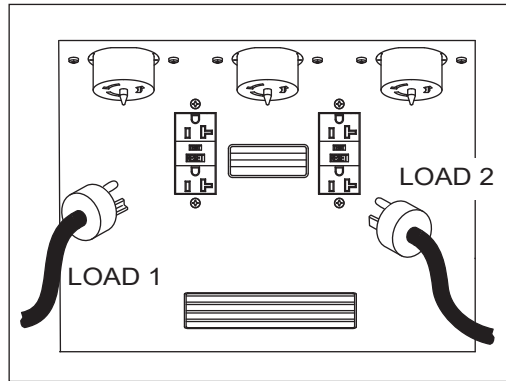

wc_gr011320

When using the 240V twist-lock receptacle and a distribution box, instead of plugging both loads in to the same duplex receptacle of the distribution panel, plug the first load in to one of the duplex receptacles. Then, plug the second load in to a different duplex receptacle of the distribution box.

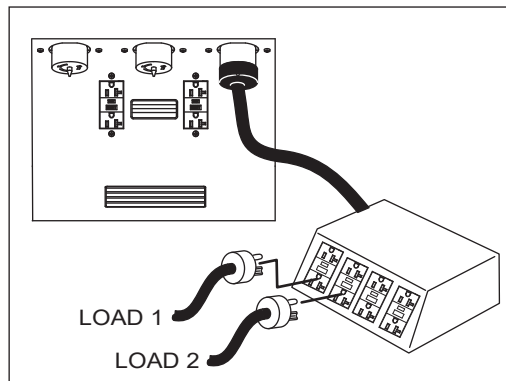

wc_gr011321

11.3 Connecting 480V, 3-Phase and Single-Phase Loads



WARNING

Electric shock hazard. High voltage can cause serious injury or death.

► Connections must be made by a qualified electrician.

1. Stop the engine and turn the main circuit breaker off.
2. Turn the voltage selector switch to the 277/480 position.
3. Open the lug door and connect the wires from the load as shown.
4. Close the lug door.
5. Start the machine and fine-tune the voltage as necessary using the voltage adjustment rheostat.

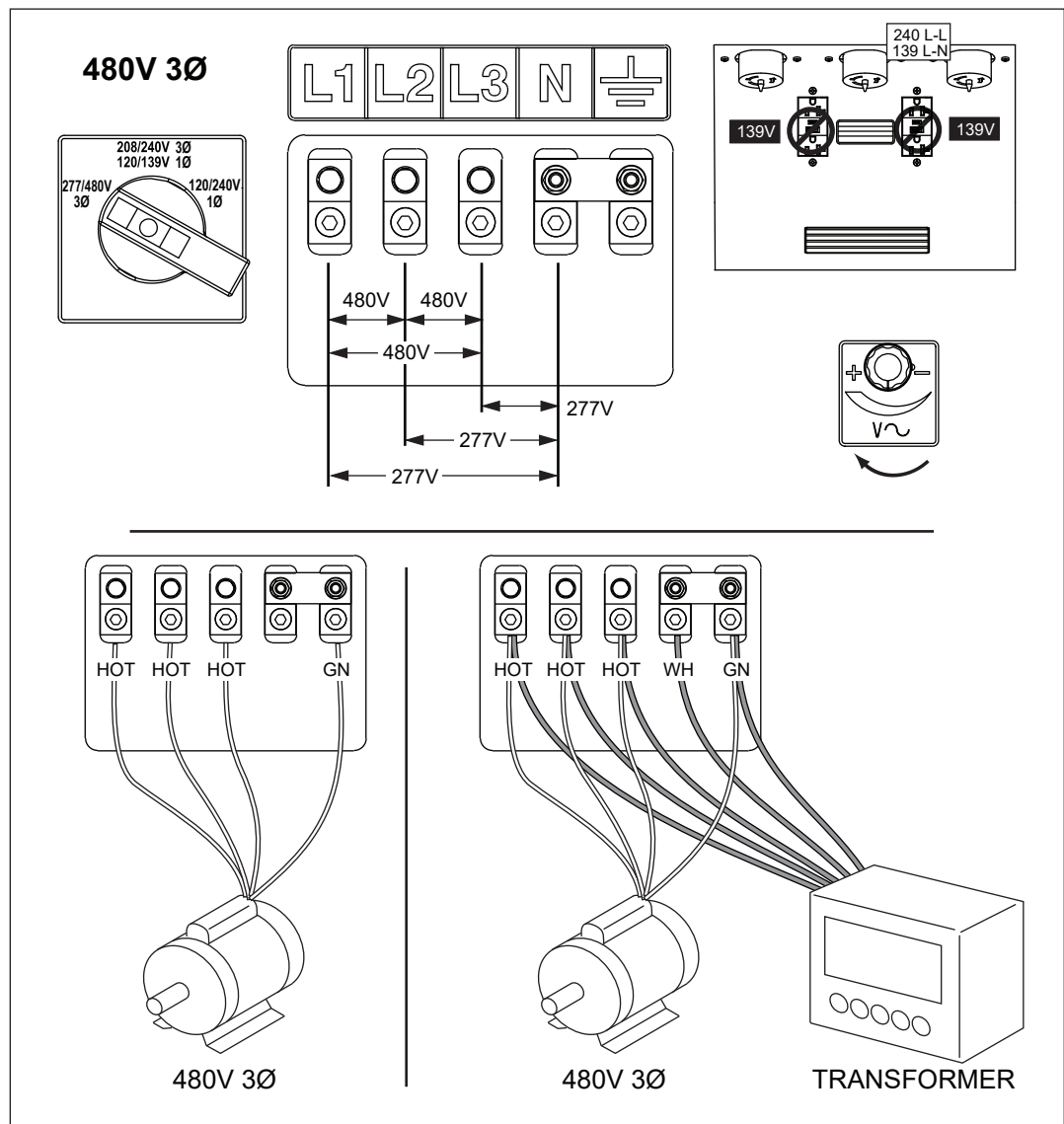

wc_gr011437

11.4 Connecting a 240V 3Ø Load and a 240V 1Ø Load



WARNING

Electric shock hazard. High voltage can cause serious injury or death.

► Connections must be made by a qualified electrician.

1. Stop the engine and turn the main circuit breaker off.
2. Turn the voltage selector switch to the 208/240 position.
3. Open the lug door and connect the wires from the load as shown.
4. Close the lug door.
5. Start the machine and fine-tune the voltage as necessary using the voltage adjustment rheostat.

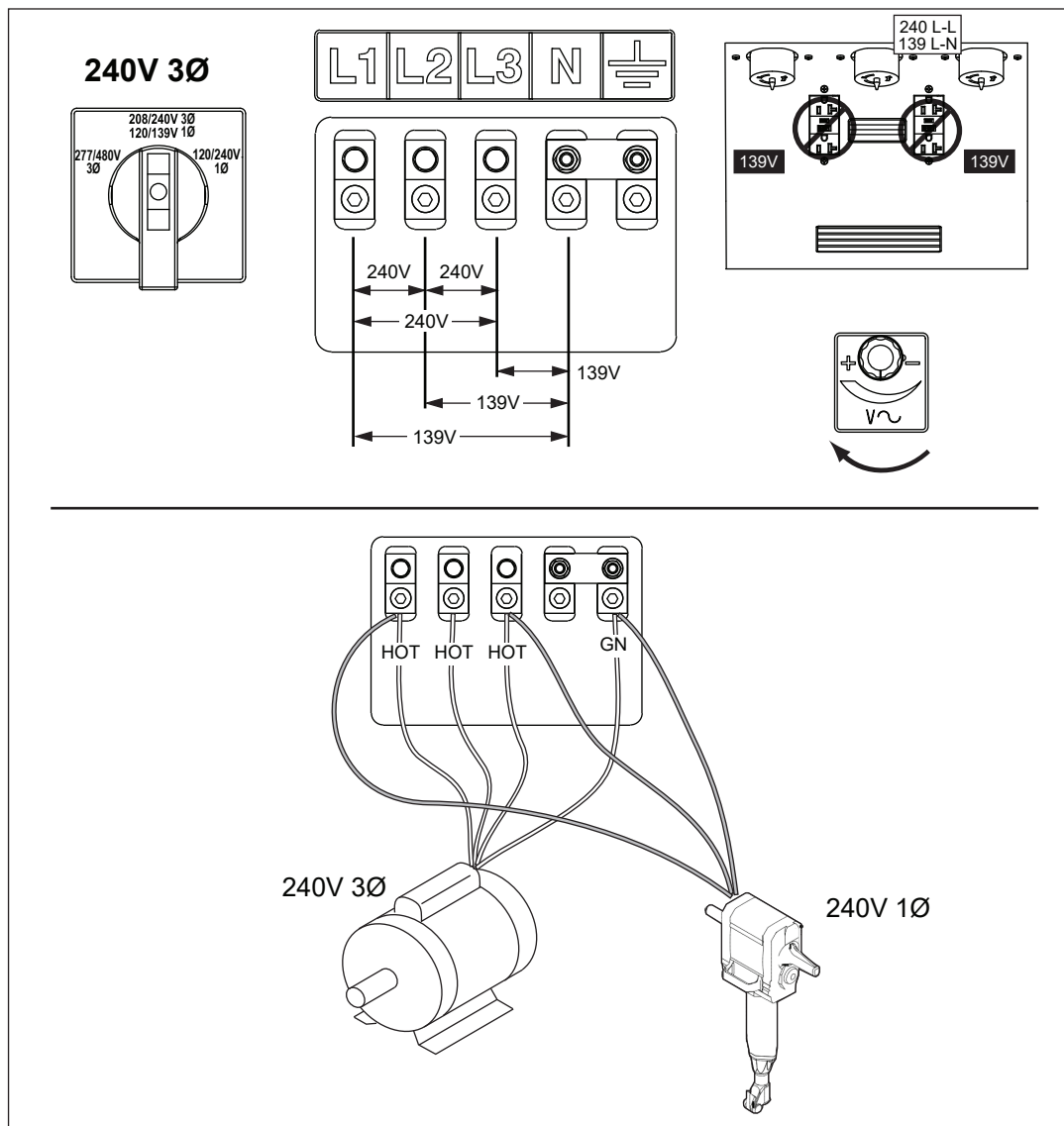

wc_gr011438-480V

11.5 Connecting 240V and 120V Single-Phase Loads



WARNING

Electric shock hazard. High voltage can cause serious injury or death.

► Connections must be made by a qualified electrician.

Background

Single-phase loads may be connected at the lugs by connecting the load “line to line” or by connecting the load “line to neutral”. Line-to-line connections use two “hots” and ground; line-to-neutral connections use one “hot”, neutral, and ground.

Procedure

1. Stop the engine and turn the main circuit breaker off.
2. Turn the voltage selector switch to the 120/240V position.
3. Open the lug door and connect the wires from the load(s) as shown.
4. Close the lug door and start the machine.
5. Fine-tune the voltage as necessary using the voltage adjustment rheostat

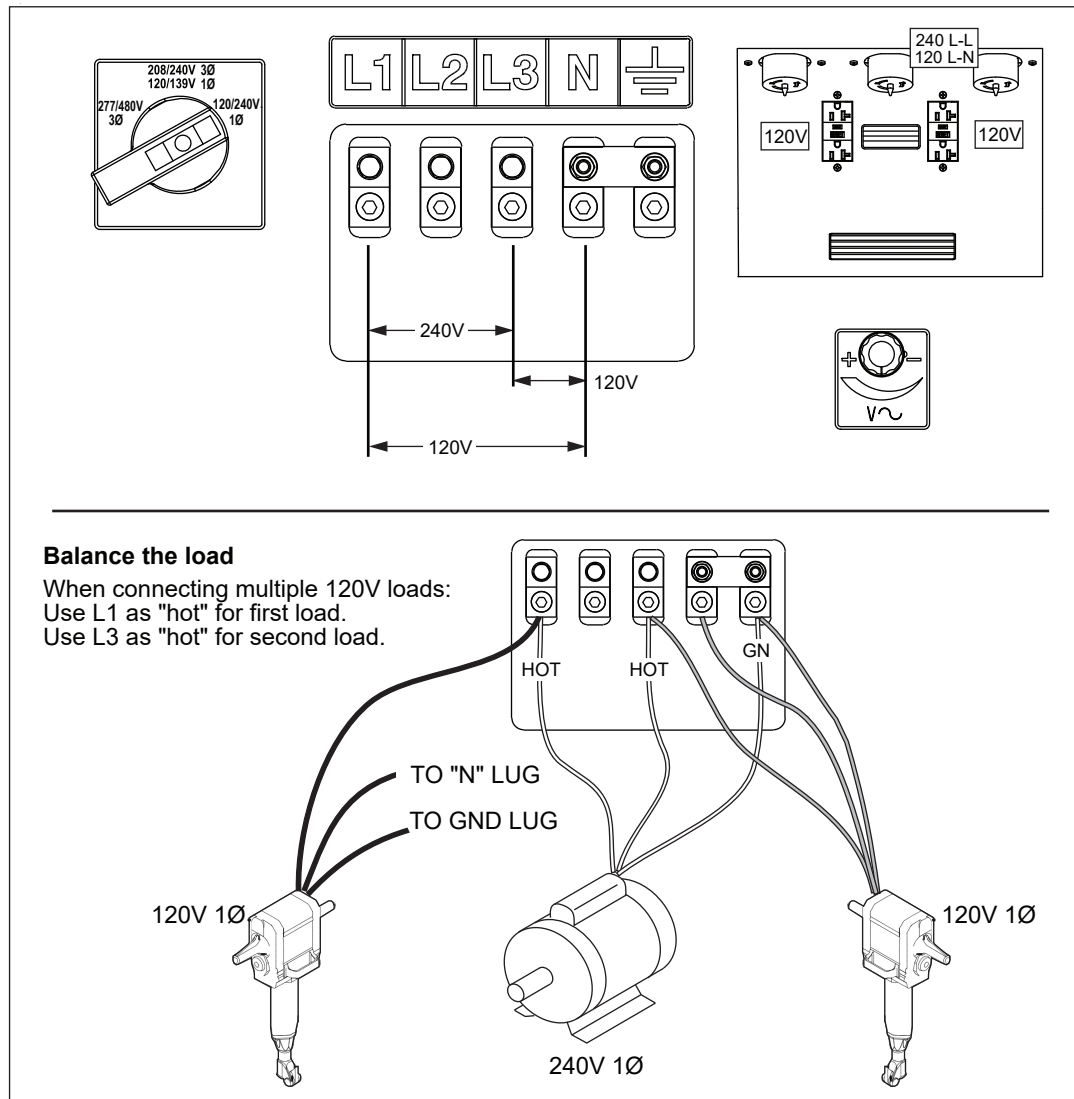

wc_gr011440-480V

11.6 Connecting a 208V 3Ø Load and Multiple 120V 1Ø Loads



WARNING

Electric shock hazard. High voltage can cause serious injury or death.

► Connections must be made by a qualified electrician.

1. Stop the engine and turn the main circuit breaker off.
2. Turn the voltage selector switch to the 208/240 position.
3. Open the lug door and connect the wires from the load as shown.
4. Close the lug door and start the machine.
5. Fine-tune the voltage as necessary using the voltage adjustment rheostat.

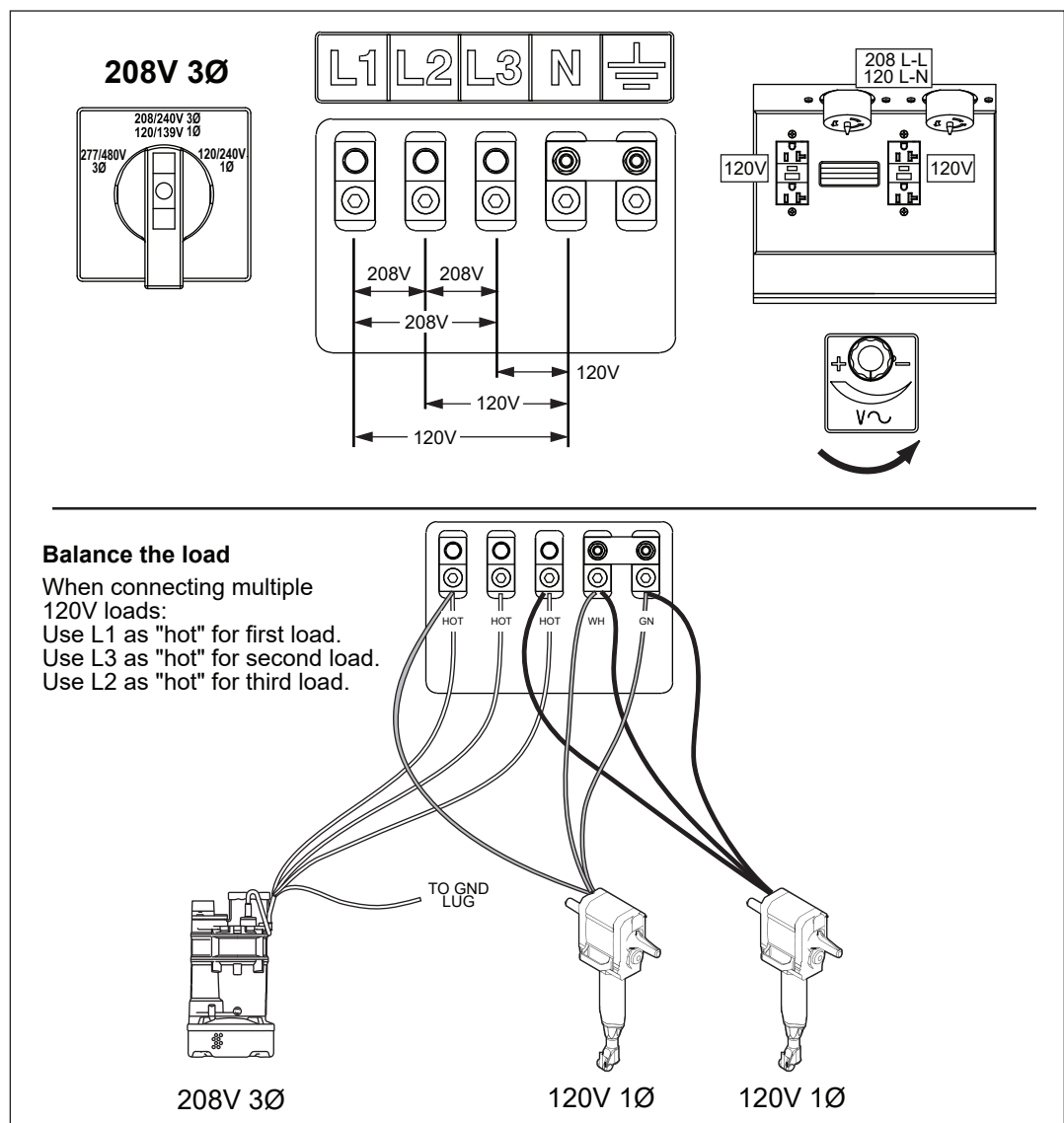

wc_gr011441-480V

11.7 Connecting a 220–240V 3Ø Load and Multiple 127–133V 1Ø Loads



WARNING

Electric shock hazard. High voltage can cause serious injury or death.

► Connections must be made by a qualified electrician.

1. Stop the engine and turn the main circuit breaker off.
2. Turn the voltage selector switch to the 208/240 position.
3. Open the lug door and connect the wires from the load(s) as shown.
4. Close the lug door and start the machine.
5. Fine-tune the voltage as necessary using the voltage adjustment rheostat.

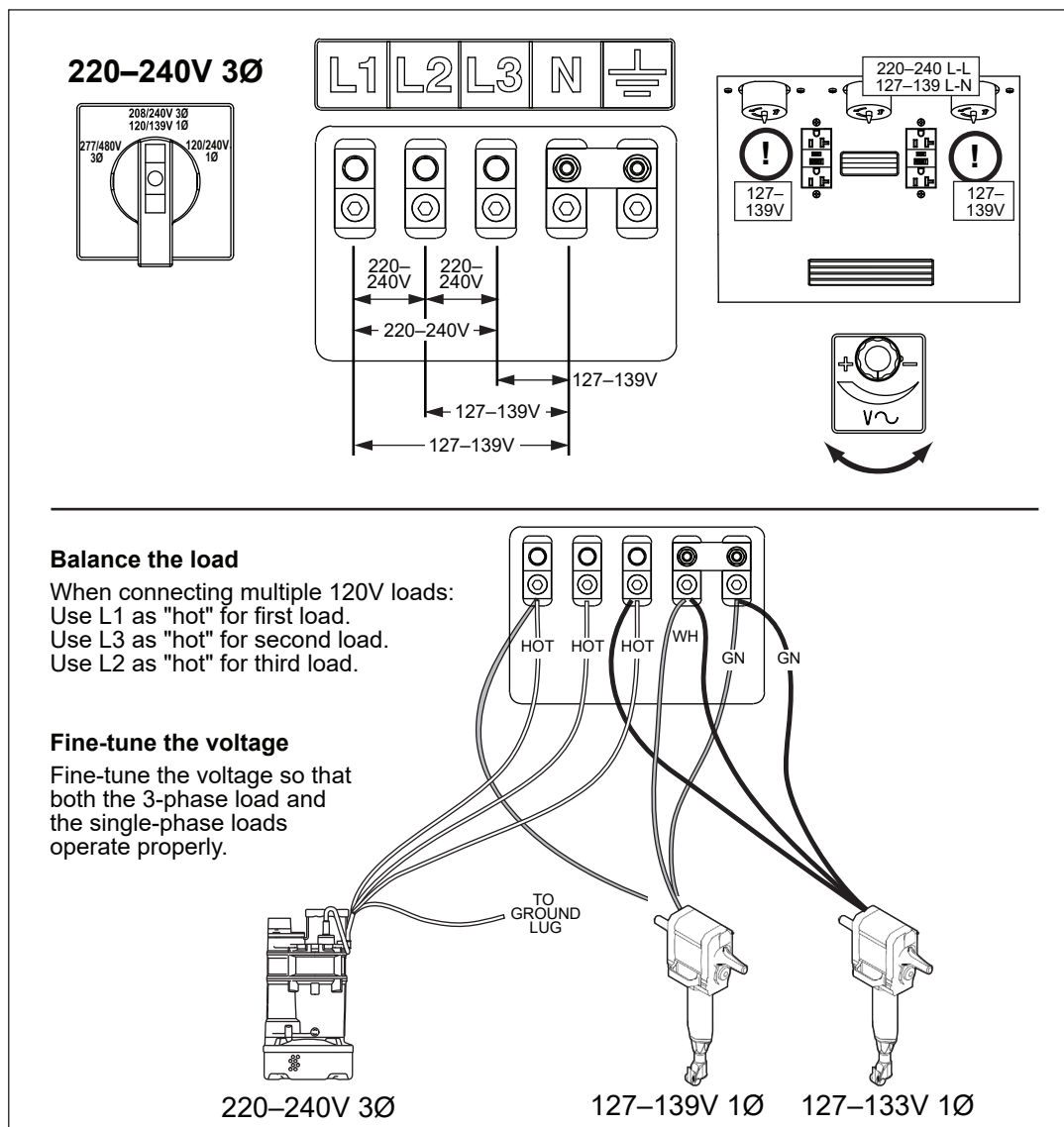

wc_gr011442-480V

12 How to Connect Loads—600V

The information in this chapter on how to connect loads applies to machines with maximum capabilities up to 600V.

This chapter does not apply to machines with maximum capabilities of only 480V.

12.1 Lug Terminal Connection Diagrams

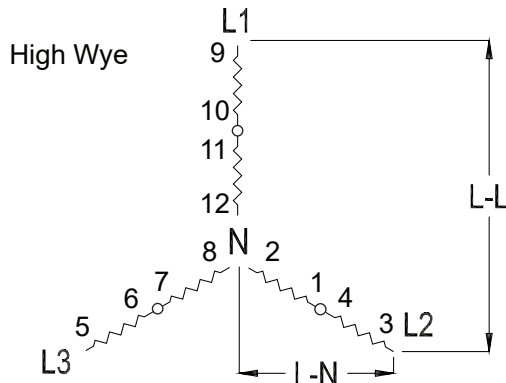

wc_gr011347

- L1-N = 346V
- L2-N = 346V
- L3-N = 346V
- L1-L2 = 600V
- L2-L3 = 600V
- L3-L1 = 600V

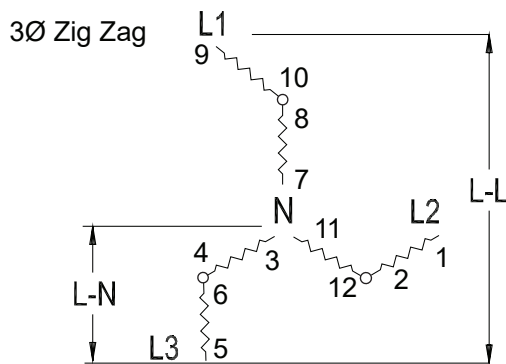
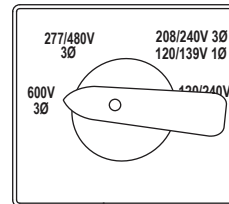

- L1-N = 277V
- L2-N = 277V
- L3-N = 277V
- L1-L2 = 480V
- L2-L3 = 480V
- L3-L1 = 480V

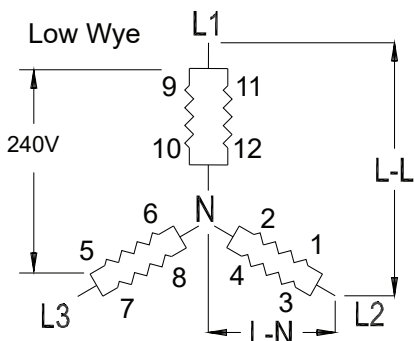
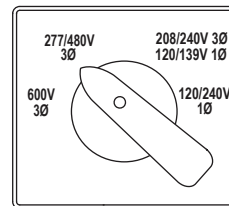

- | | | |
|--------------|----|--------------|
| L1-N = 120V | or | L1-N = 139V |
| L2-N = 120V | | L2-N = 139V |
| L3-N = 120V | | L3-N = 139V |
| L1-L2 = 208V | | L1-L2 = 240V |
| L2-L3 = 208V | | L2-L3 = 240V |
| L3-L1 = 208V | | L3-L1 = 240V |

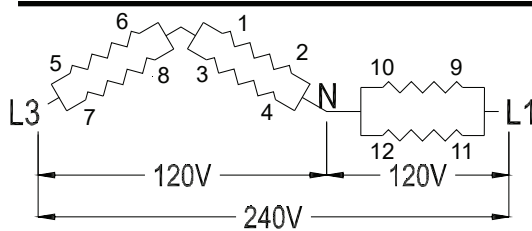
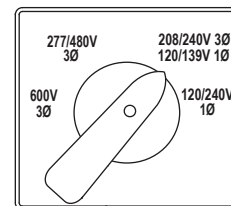

- L1-L3 = 240V
- L1-N = 120V
- L2-N = ----
- L3-N = 120V

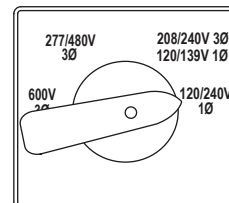

12.2 Best Practices for Balancing Loads



WARNING

Electric shock hazard. High voltage can cause serious injury or death.

- Connections must be made by a qualified electrician.

Background

Three-phase (3Ø) loads are, by their nature, balanced. It is when single-phase (1Ø) loads are combined with existing 3Ø loads that an unbalanced condition can occur. Dedicated 1Ø loads may also be unbalanced if the loads are not equally distributed between the legs (L1 and L3) of the generator.

The sensing wires of the generator’s voltage regulator are connected to L1 and L3. Having the loads balanced between L1 and L3 allows the generator to provide voltage that is more consistent with the voltage needs of the equipment connected to it.

Note: *When in the 600V mode, single phase power is not available.*

1Ø Situations

For 1Ø situations (voltage selector switch in the 208/240V position)

Unbalanced loads can be detected by observing the generator controller LCD panel. If an unbalanced load condition exists, there will be a significant difference (over 10%) in both voltage and amperage between the legs.

Observe the amp draw on L1 and L3.

Note: *Basler controller screens are shown. For Deep Sea controller machines, see chapter Working with Deep Sea Controller: DSE 7310 MKII for the corresponding parameters.*

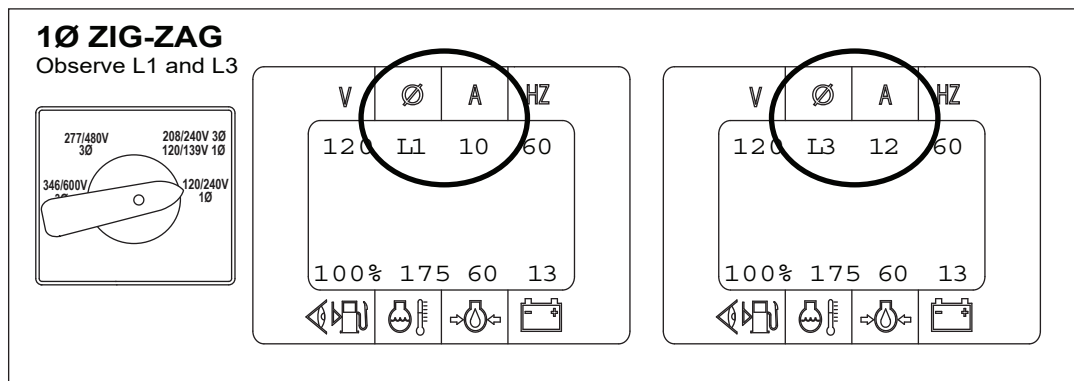

wc_gr011280-600V

If an unbalanced load condition is detected, stop the engine and reconnect the loads so that loads (amp draw) are more equally distributed between the legs (L1 and L3)—for example, if a heavy load and a light load are connected to L1, but only a light load is connected to L3. Reconnect the loads so that the heavy load is connected to L1, and the two lighter loads are connected to L3. Redistributing the loads will equalize the voltage for each leg and allow for better performance from the equipment connected to the generator.

Reconnect the loads as necessary to provide the most equal amp draw between L1 and L3.

This procedure continues on the next page.

Continued from the previous page.

3Ø Situations When combining 1Ø loads with 3Ø loads (voltage selector switch in 208/240V position), unbalanced loads can be detected by observing the generator controller LCD panel. If an unbalanced load condition exists, there will be a significant difference in both voltage and amperage between the phases.

Observe the amp draw on P1, P2, and P3.

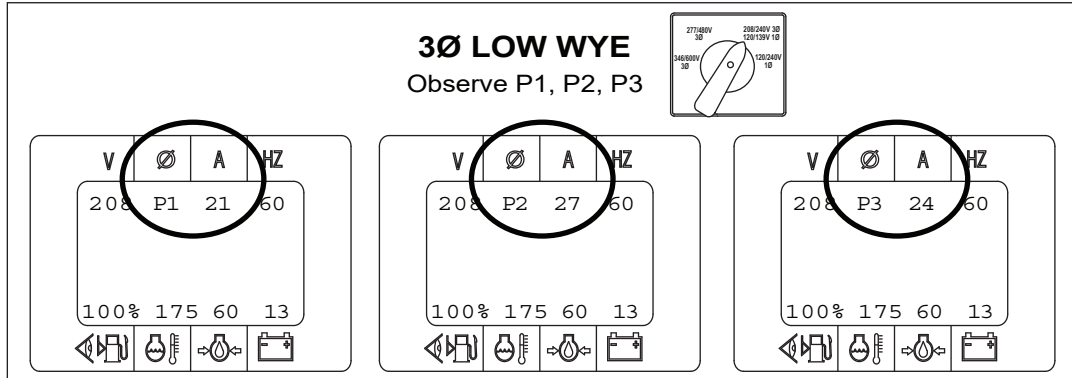

wc_gr011281-600V

If an unbalanced load is detected, stop the engine and reconnect the loads so that loads (amp draw) are more equally distributed. This will also help equalize the voltage for each phase.

When connecting multiple 120V 1Ø loads to the lugs while in 208/240V 3Ø mode, use L1 as “hot” for the first load (or heaviest load). Use L3 as “hot” for the second load (or next heaviest load), and use L2 as “hot” for the third load (lightest load). If additional loads are to be connected, repeat the connection sequence L1, L3, and then L2.

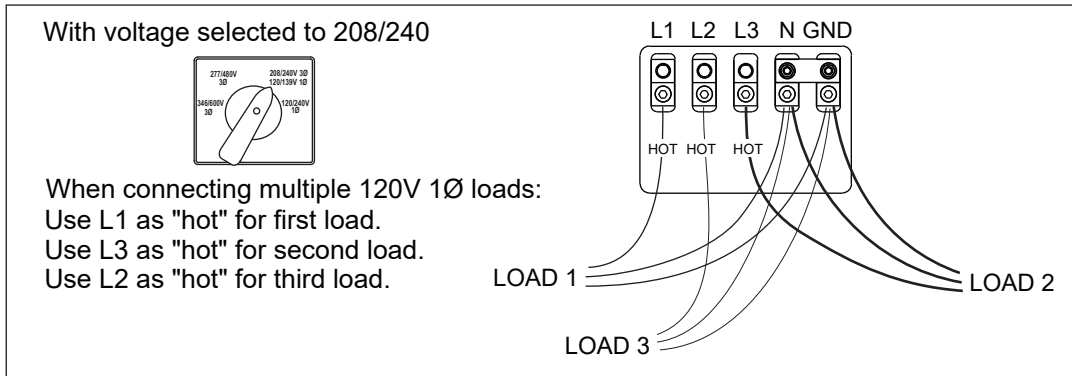

wc_gr011282-600V

This procedure continues on the next page.

Continued from the previous page.

Using the receptacles

This information applies whether the machine is running in 3Ø or in 1Ø.

Note: *When in the 600V mode, single phase power is not available.*

When connecting two loads to the duplex receptacles, instead of plugging both loads in to the same duplex receptacle, plug the first load in to one of the duplex receptacles. Then, plug the second load in to the other duplex receptacle. Additional loads can be plugged in to either duplex receptacle.

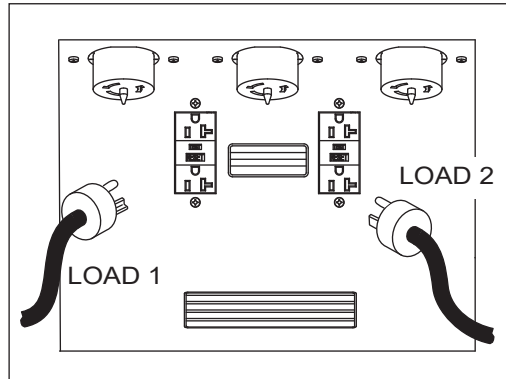

wc_gr011320

When using the 240V twist-lock receptacle and a distribution box, instead of plugging both loads in to the same duplex receptacle of the distribution panel, plug the first load in to one of the duplex receptacles. Then, plug the second load in to a different duplex receptacle of the distribution box.

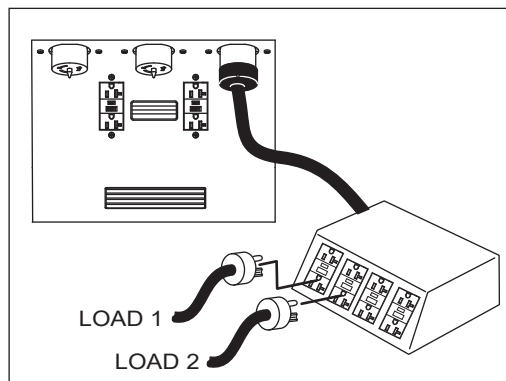

wc_gr011321

12.3 Connecting a 240V 3Ø Load and a 240V 1Ø Load



WARNING

Electric shock hazard. High voltage can cause serious injury or death.

► Connections must be made by a qualified electrician.

1. Stop the engine and turn the main circuit breaker off.
2. Turn the voltage selector switch to the 208/240 position.
3. Open the lug door and connect the wires from the load as shown.
4. Close the lug door.
5. Start the machine and fine-tune the voltage as necessary using the voltage adjustment rheostat.

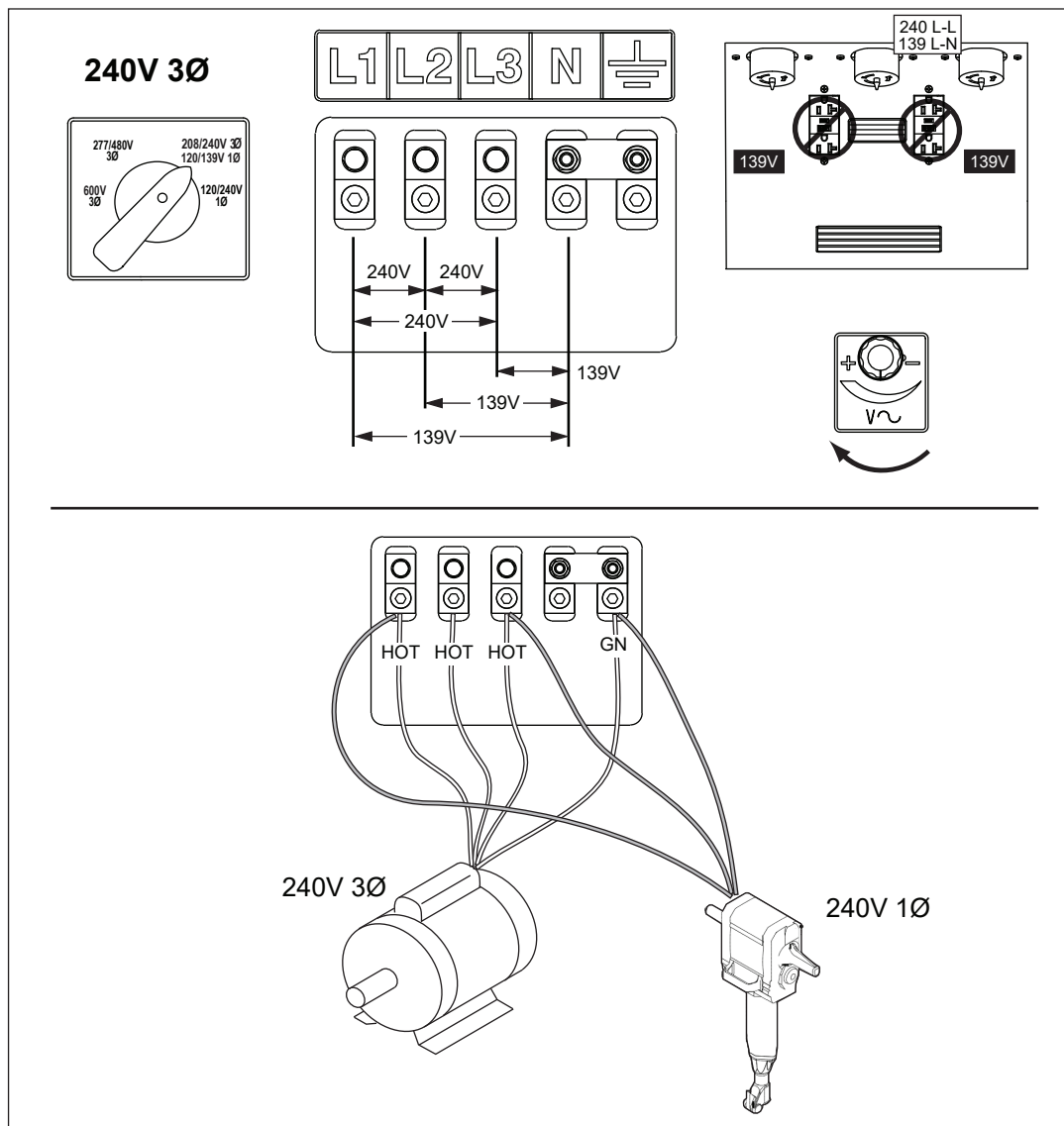

wc_gr011438-600V

12.4 Connecting 240V and 120V Single-Phase Loads



WARNING

Electric shock hazard. High voltage can cause serious injury or death.

► Connections must be made by a qualified electrician.

Background

Single-phase loads may be connected at the lugs by connecting the load “line to line” or by connecting the load “line to neutral”. Line-to-line connections use two “hots” and ground; line-to-neutral connections use one “hot”, neutral, and ground.

Procedure

1. Stop the engine and turn the main circuit breaker off.
2. Turn the voltage selector switch to the 120/240V position.
3. Open the lug door and connect the wires from the load(s) as shown.
4. Close the lug door and start the machine.
5. Fine-tune the voltage as necessary using the voltage adjustment rheostat

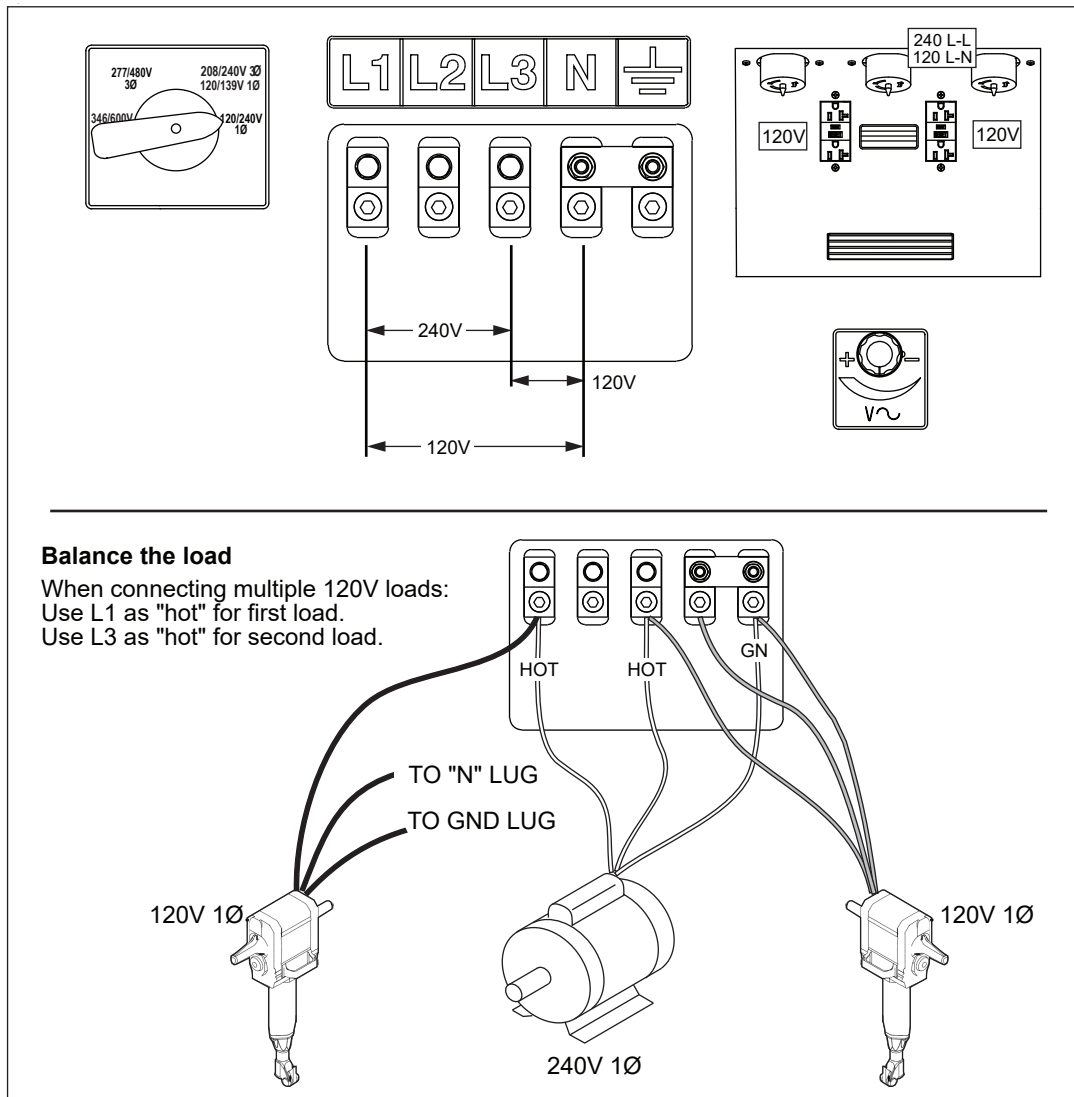

wc_gr011440-600V

12.5 Connecting a 208V 3Ø Load and Multiple 120V 1Ø Loads



WARNING

Electric shock hazard. High voltage can cause serious injury or death.

► Connections must be made by a qualified electrician.

1. Stop the engine and turn the main circuit breaker off.
2. Turn the voltage selector switch to the 208/240 position.
3. Open the lug door and connect the wires from the load as shown.
4. Close the lug door and start the machine.
5. Fine-tune the voltage as necessary using the voltage adjustment rheostat.

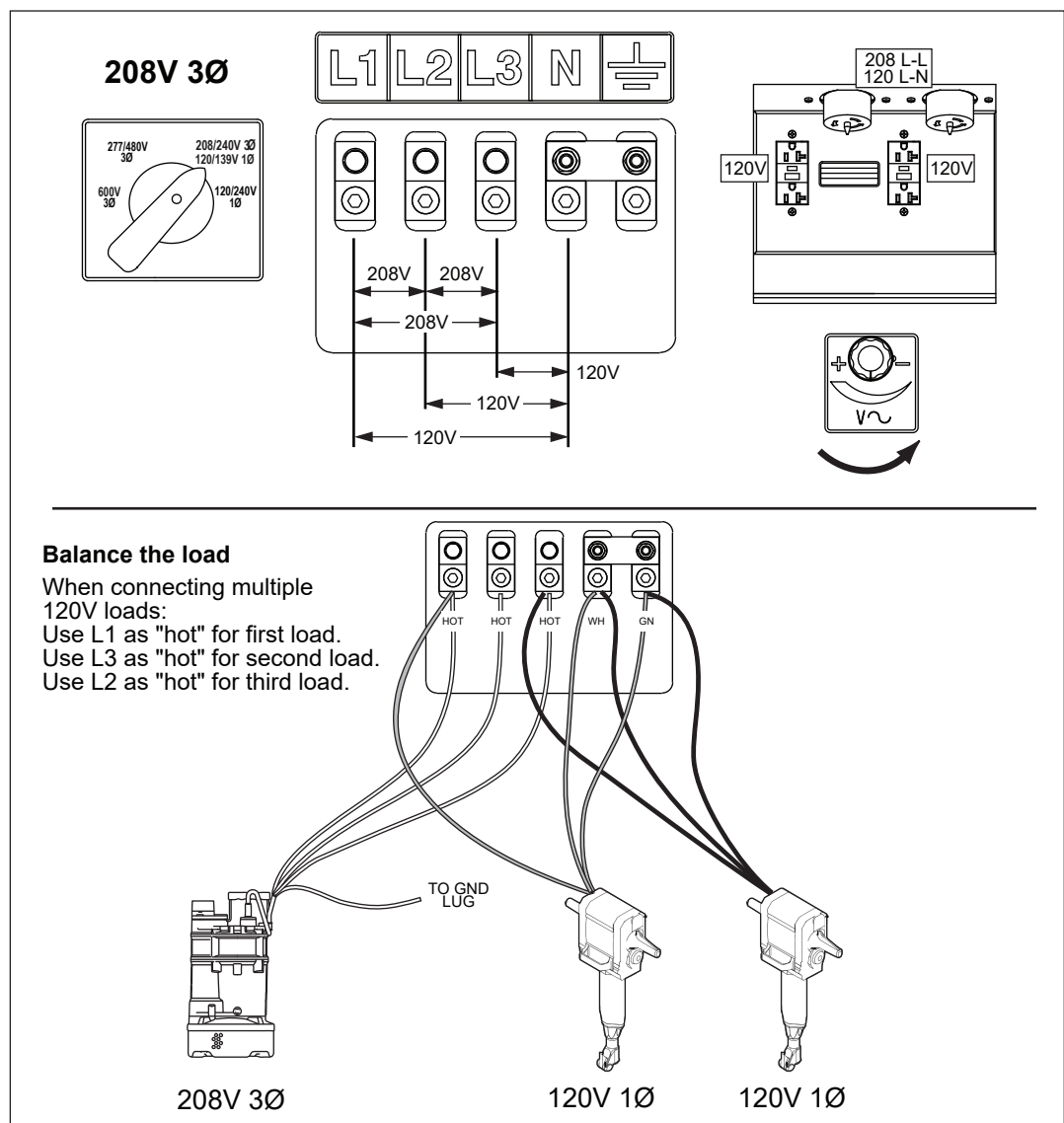

wc_gr011441-600V

12.6 Connecting a 220–240V 3Ø Load and Multiple 127–133V 1Ø Loads



WARNING

Electric shock hazard. High voltage can cause serious injury or death.

► Connections must be made by a qualified electrician.

1. Stop the engine and turn the main circuit breaker off.
2. Turn the voltage selector switch to the 208/240 position.
3. Open the lug door and connect the wires from the load(s) as shown.
4. Close the lug door and start the machine.
5. Fine-tune the voltage as necessary using the voltage adjustment rheostat.

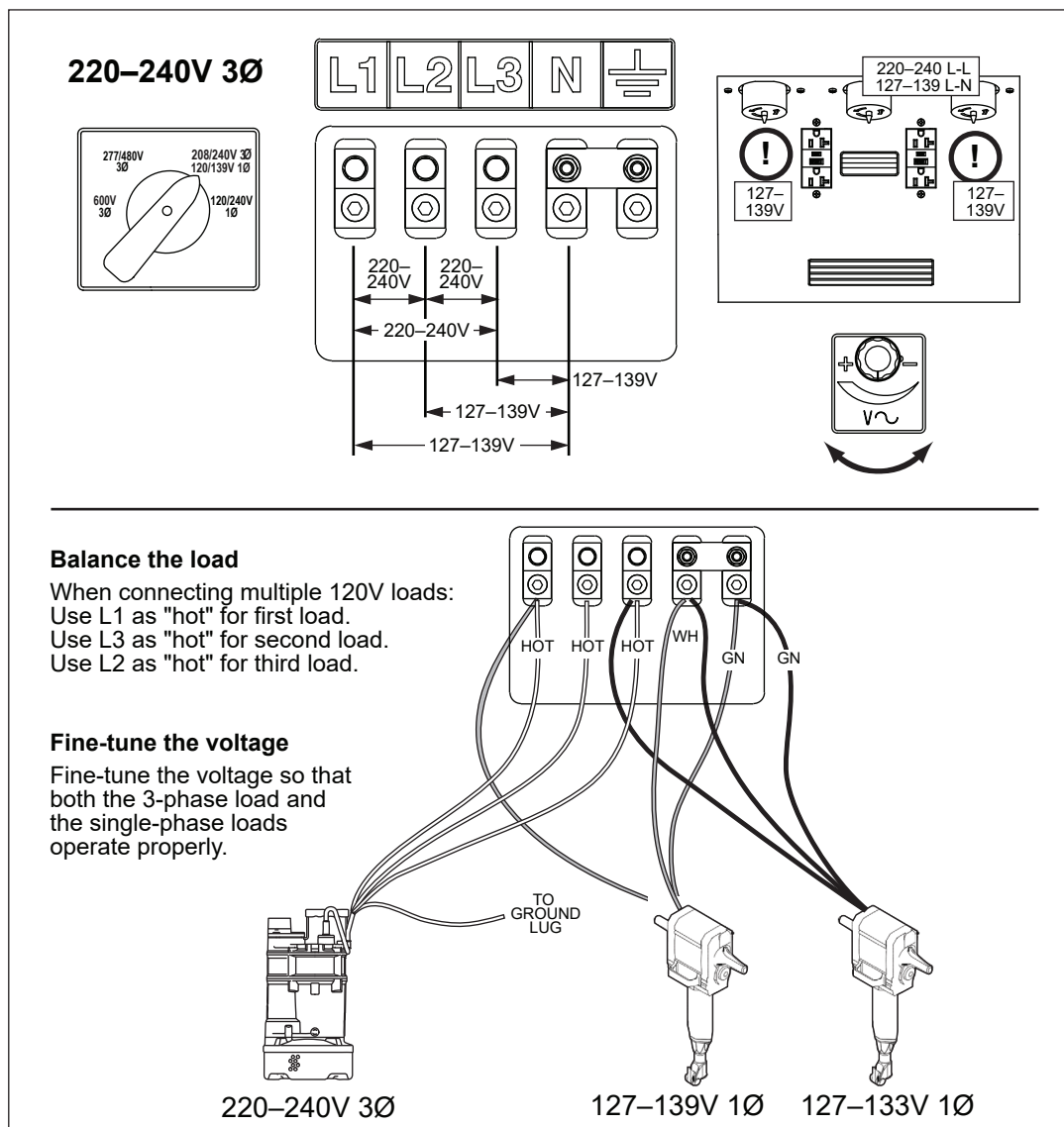

wc_gr011442-600V

12.7 Connecting 480V, 3-Phase Loads



WARNING

Electric shock hazard. High voltage can cause serious injury or death.

► Connections must be made by a qualified electrician.

1. Stop the engine and turn the main circuit breaker off.
2. Turn the voltage selector switch to the 277/480 position.
3. Open the lug door and connect the wires from the load as shown.
4. Close the lug door.
5. Start the machine and fine-tune the voltage as necessary using the voltage adjustment rheostat.

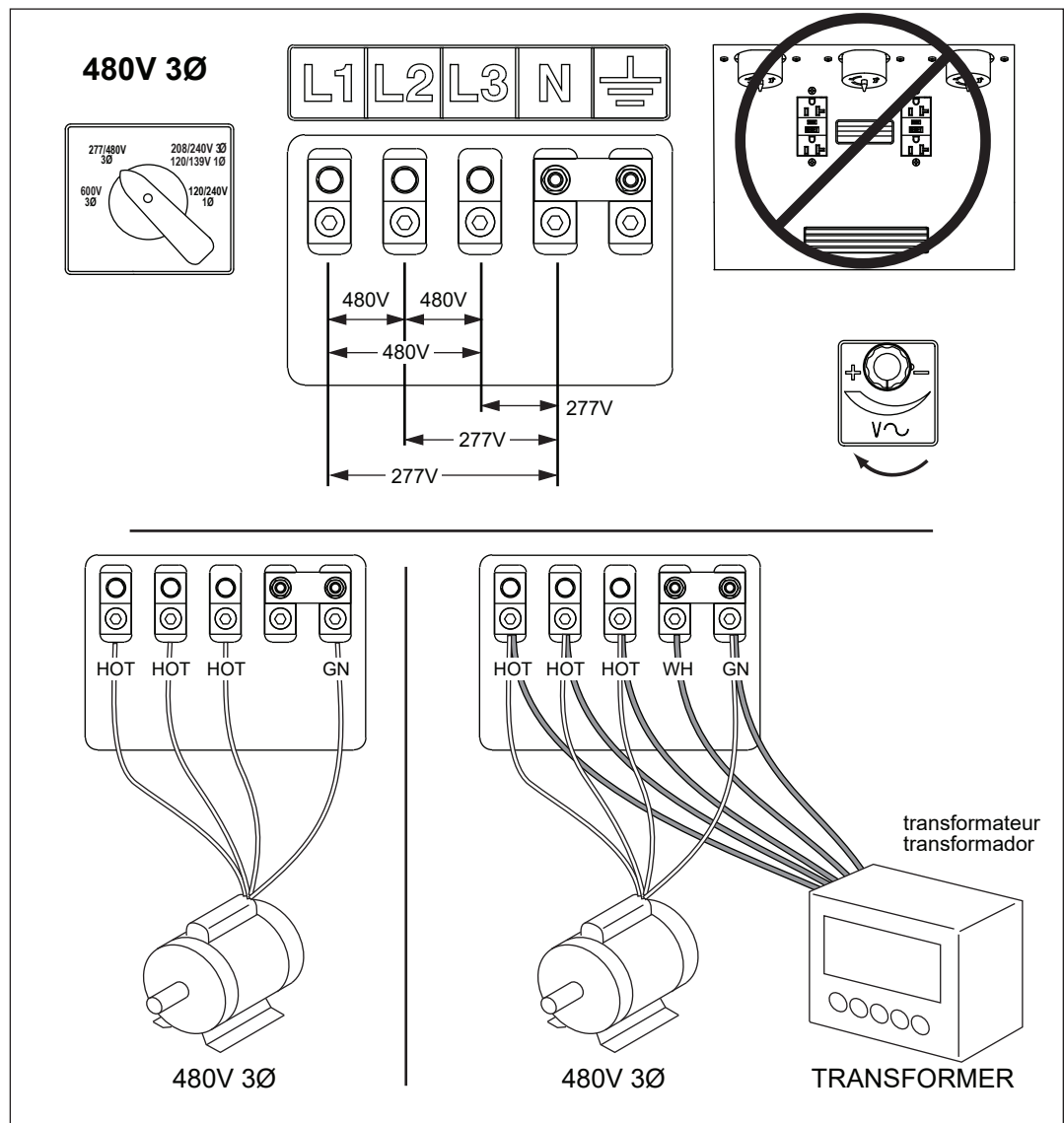

wc_gr011843

12.8 Connecting 600V, 3-Phase Loads



WARNING

Electric shock hazard. High voltage can cause serious injury or death.

► Connections must be made by a qualified electrician.

1. Stop the engine and turn the main circuit breaker off.
2. Turn the voltage selector switch to the 600 position.
3. Open the lug door and connect the wires from the load as shown.
4. Close the lug door.
5. Start the machine and fine-tune the voltage as necessary using the voltage adjustment rheostat.

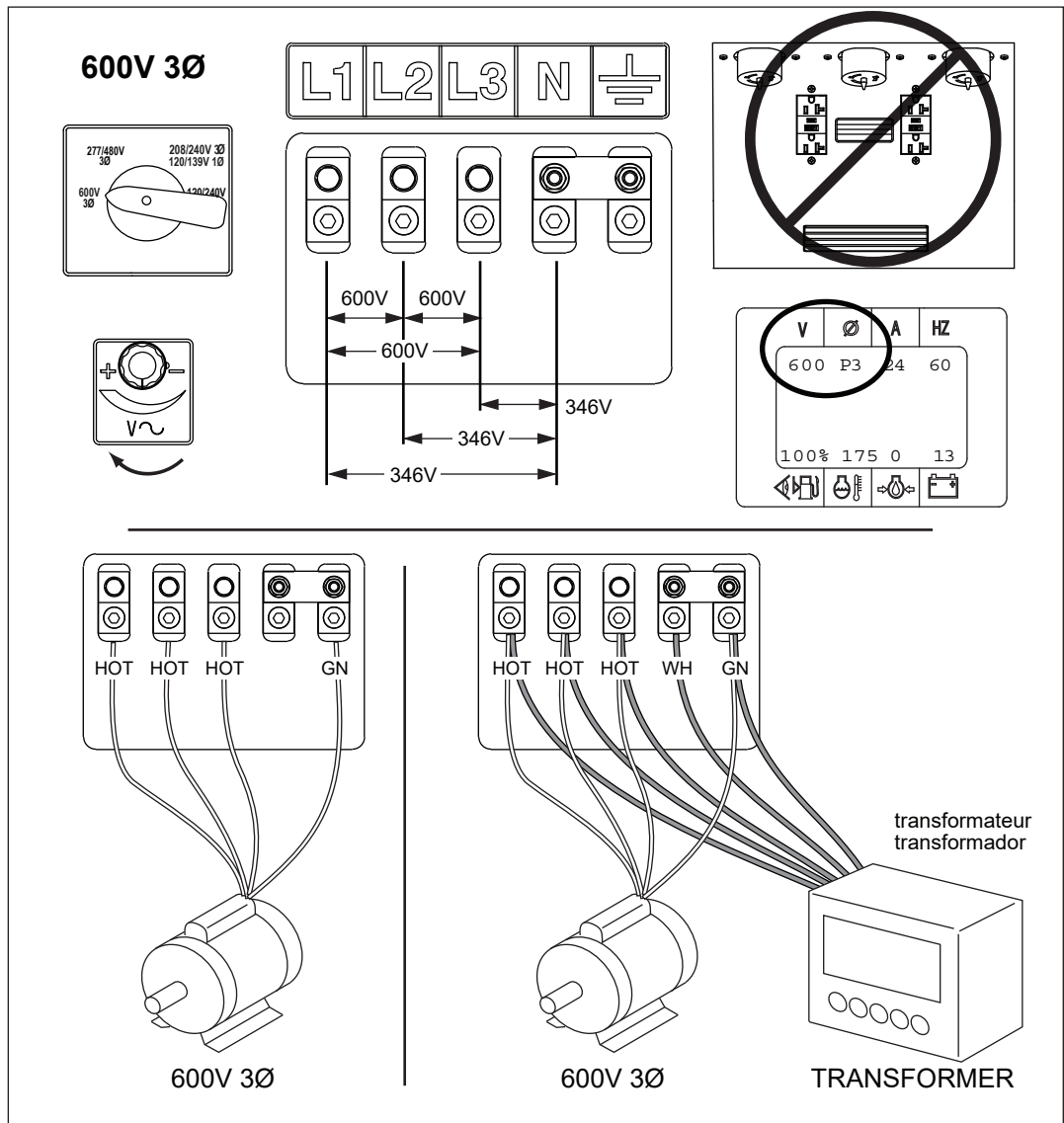

wc_gr011356

13 Using Remote Start Capabilities

13.1 Remote Run Terminal Block

Location The remote run terminal block **(a)** is located as shown.

Note: *Graphic is representative only. Your machine may vary.*

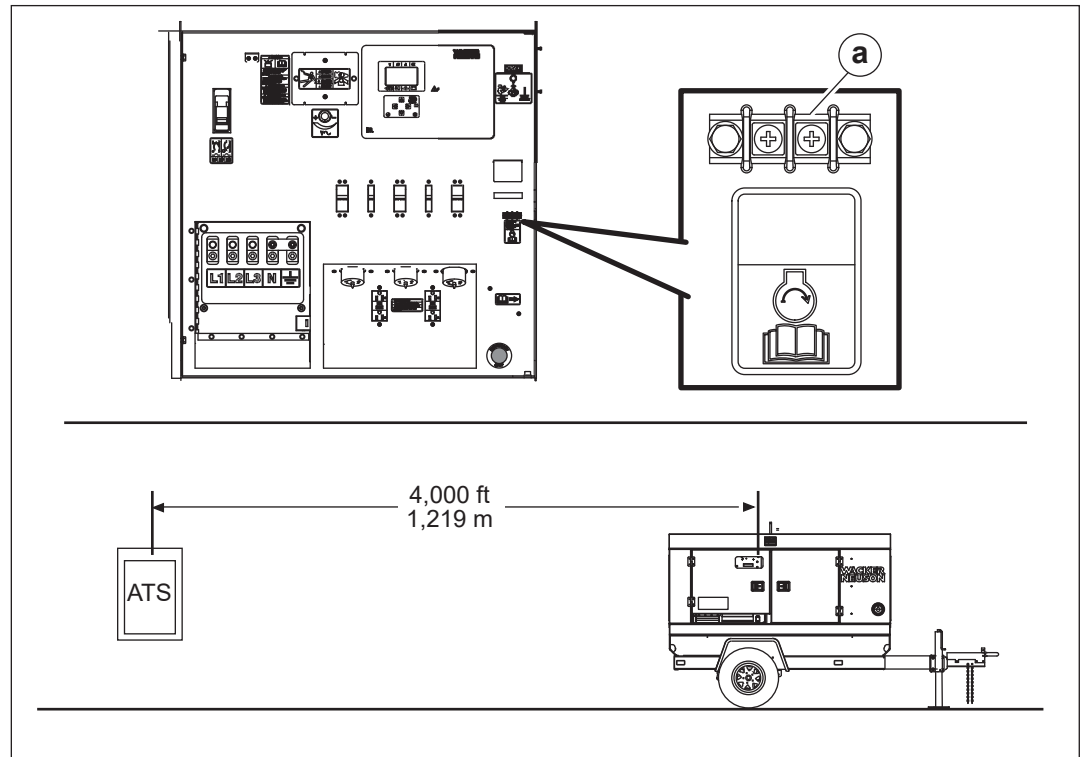

wc_gr010366

Description The remote run terminal block provides connection points for the installation of a remotely located transfer/start switch. If a transfer switch is installed, the generator can be used as a stand-by power supply.

When connecting an Automatic Transfer Switch (ATS) or other remote switch:

- Limit the distance between the remote run terminal block and the remote switch to 1,219 m (4,000 ft) max.
- Use twisted, 22-gauge wire or heavier.
- Do not run the wire for the remote switch in the same conduit as current carrying wire.
- Do not run a voltage to the contacts (these are dry contacts).

13.2 Remote Transfer Switch

Background A remote transfer switch is designed to transfer electrical loads from the normal power source (utility) to the emergency power source (generator) when normal voltage falls below a prescribed level.

The remote transfer switch automatically returns the load back to the normal source when power is restored back to operating levels.



WARNING

Electrocution hazard. Failure to isolate the generator from the utility's electrical distribution system could cause output from the generator to backfeed into the utility lines and cause injury or death to utility workers.

- ▶ When the generator is used as a stand-by power supply, it must be equipped with a device which isolates it from the utility's distribution system.
- ▶ An isolation device is also required if the generator is being used as a backup to some other type of power supply system.

Precautions

- Installation of a remote transfer switch or other type of remote starting device is the responsibility of the generator user.
- Installation of such devices must be performed by a qualified electrician following all directions supplied by the manufacturer of the switch.
- If attaching the generator to a power supply normally serviced by a utility company, notify the utility company and check local and state regulations.
- Familiarize yourself with all instructions and warning labels supplied with the switch.



CAUTION

Possibility of injury or equipment damage. Failure to match phase rotation and voltage may cause equipment connected to the generator to operate incorrectly.

- ▶ When using the generator as a stand-by or substitute power supply, make sure the voltage and phase rotation of the line connections match those of the utility lines or of any other power source normally used.



DANGER

Electrocution hazard. Lethal voltage is always present in the transfer switch once it has been properly installed.

- ▶ Disconnect power before servicing the transfer switch.

13.3 Preparing for Automatic/Remote Start-Up—Deep Sea

Background In AUTO mode, the generator can be started remotely, either through a transfer switch or some other type of remote start switch. AUTO mode is the normal setting when using the generator as a stand-by power supply.

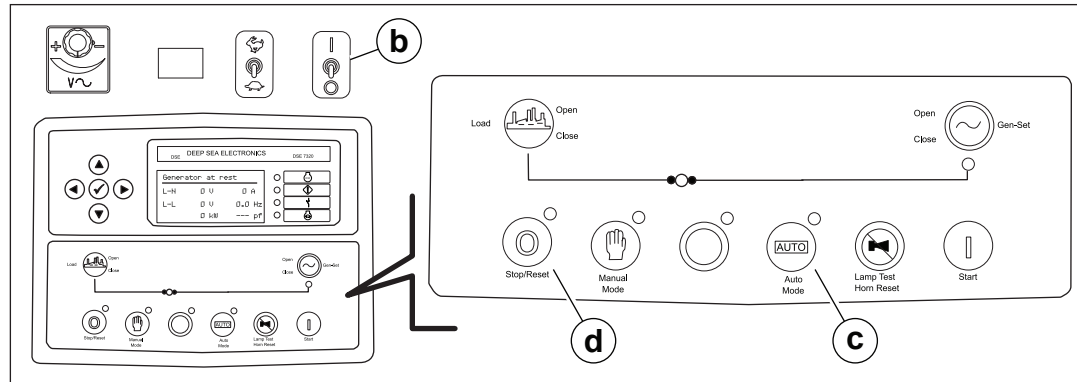

wc_gr011501



CAUTION

Possibility of accidental equipment start-up. If the contacts on any remote switch linked to the generator are closed, the generator could start unexpectedly when the AUTO mode button is pressed.

- ▶ Before pressing the AUTO mode button, verify that the contacts on any remote switch linked to the generator are OPEN.

Procedure

1. Before using the AUTO mode, perform a check of the auto start-up circuit. To do so:
 - a. Attach a short jumper wire (a) (minimum 16-gauge insulated) between the two terminals on the remote run terminal block. The jumper wire applies a ground to the ECM to complete the start circuit.
 - b. Set the generator controller power switch (b) to the ON position.
 - c. Press the AUTO mode button (c).
 - d. Wait for the engine to crank, start, and run. If the engine cranks, the remote start circuit is functioning.
 - e. Press the Stop/Reset "O" button (d) to stop the engine.
 - f. Remove the jumper wire from the remote run terminals after testing is complete.

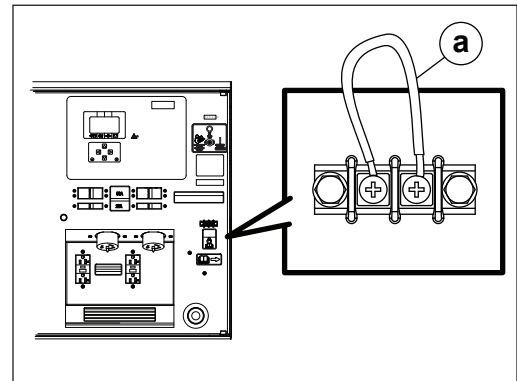

wc_gr010206

This procedure continues on the next page.

Continued from the previous page.

2. Leave the generator controller power switch in the ON position.
3. Close the main circuit breaker.
4. Press the AUTO mode button.
5. Secure the generator by closing and locking all doors.

The generator is now ready for automatic starting.

Maintaining battery charge

If the generator is to be used as a stand-by power supply, provisions must be made to maintain the battery charge. This can be done either by attaching a battery charger to the battery or by starting the generator manually and running the engine periodically to maintain the battery charge.

14 Diagnostic Trouble Codes (DTC)

14.1 Accessing DTCs with the Basler Controller

Background This machine may include an engine that has self-diagnostic capabilities. These engines communicate issues with the engine through Diagnostic Trouble Codes (DTCs). When a DTC is present, an alert will show on the LCD panel display. A DTC is a two part code consisting of a Suspect Parameter Number (SPN), and a Failure Mode Identifier (FMI).

Procedure Perform the procedure below to access Diagnostic Trouble Codes.

1. At the READY screen, press the right arrow button (1) to bring up the MAIN menu.

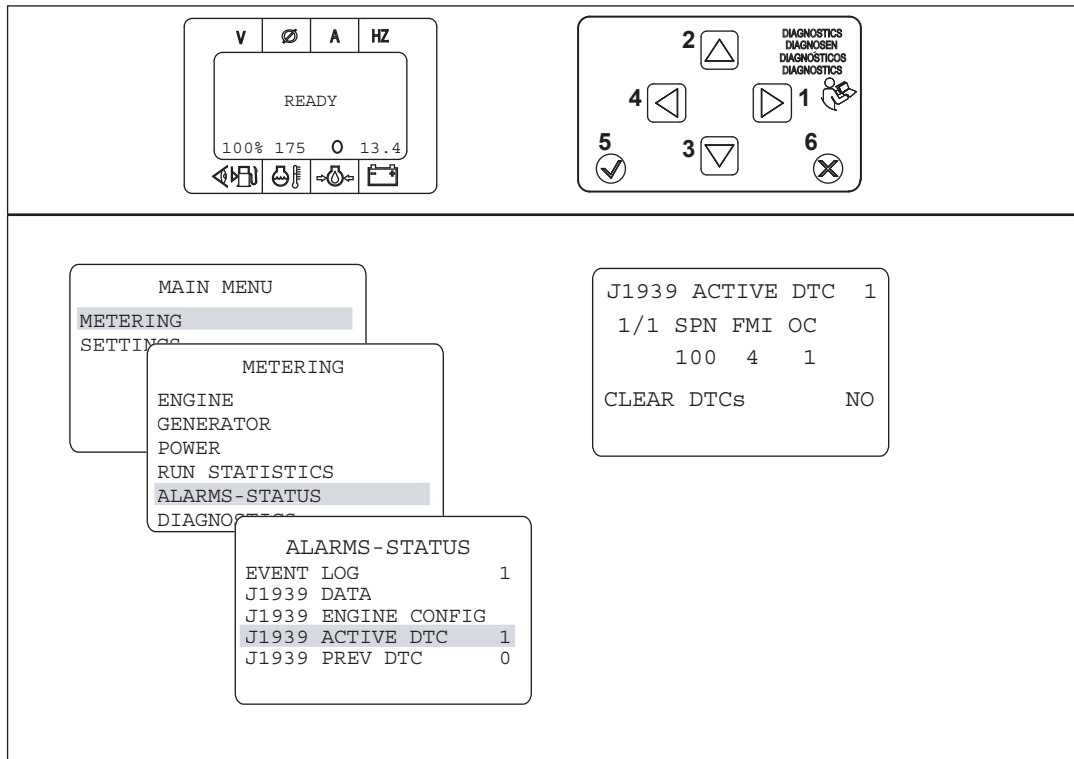

wc_gr011382

2. Highlight METERING. Then, press the right arrow button.
3. Highlight ALARMS-STATUS. Then, press the right arrow button.
4. Highlight J1939 ACTIVE DTC. Then, press the right arrow button.
5. Highlight a DTC. Then, press the check mark button (5).

Note: To access a past DTC, highlight J1939 PREV DTC. Then, press the right arrow button.

14.2 Accessing Engine DTCs using the Deep Sea Controller

Background This machine may include an engine that has self-diagnostic capabilities. These engines communicate issues with the engine through Diagnostic Trouble Codes (DTCs). When a DTC is present, an alert will show on the LCD panel display. A DTC is a two part code consisting of a Suspect Parameter Number (SPN), and a Failure Mode Identifier (FMI).

Procedure Perform the procedure below to access the Diagnostic Trouble Codes.

1. From the “status” menu, press the right arrow button to navigate through “engine”, “Generator”, “Alarms”, to “ECU DTCs”.

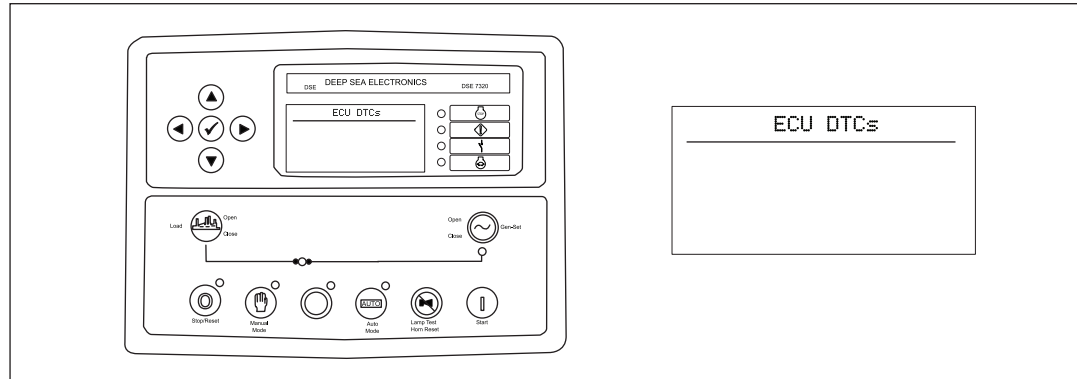

2. Use the up and down arrow buttons to scroll through the DTCs.

Note: *The Deep Sea Controller will list the most current DTC first, followed by the any other DTCs in order of their occurrence.*

14.3 List of Engine Diagnostic Trouble Codes (DTCs)

Failure Code		String Displayed	Description
SPN	FMI		
—	0	DATA HI MOST SEVERE	Data is higher than expected at the most severe level
—	1	DATA LO MOST SEVERE	Data is lower than expected at the most severe level
—	2	DATA ERRATIC OR BAD	Data is erratic, intermittent, or incorrect
—	3	VOLTS HI OR SHORTED	Measured voltage is higher than expected or shorted to a high source
—	4	VOLTS LO OR SHORTED	Measured voltage is lower than expected or shorted to a low source
—	5	CURRENT LO OR OPEN	Measured current is lower than expected or the circuit is open
—	6	CURRENT HI OR SHORTED	Measured current is higher than expected or shorted
—	7	MECHANICAL SYSTM ERR	Mechanical system error
—	8	FREQ OR PWM ERROR	Error in frequency, pulse width or period of any frequency or PWM signal is outside its predetermined limits
—	9	ABNORMAL UPDATE RATE	Update rate of parameter is abnormal
—	10	DATA RT OF CHG ERR	Rate of change of data is abnormal
—	11	FAILURE CAUSE UNKNOWN	String indicating failure cause is unknown
—	12	BAD INTELLIGNT DEVICE	Engine ECU is reporting that an intelligent device or component failure has been detected
—	13	OUT OF CALIBRATION	Device or parameter is out of calibration
—	14	CONSULT ENG MFG DATA	User should consult engine manufacturer's data
28	3	Throttle Volt HI	Throttle voltage high
28	4	Throttle Volt LO	Throttle voltage low
28	14	Throttle Volt OOR	Throttle input voltage out of range
29	3	Throttle Volt HI	Throttle voltage high
29	4	Throttle Volt LO	Throttle voltage low
29	14	Throttle Volt OOR	Throttle input voltage out of range
29	#	ACCEL PEDAL 2 POSITN	Caption string for accelerator pedal 2 position
52	15	INTERCOOLER TEMP HI	Engine intercooler temperature is above the high threshold
91	3	Thr Pos Sns Volt HI	Throttle position sensor input voltage (high)

Diagnostic Trouble Codes (DTC)

Mobile Generator

Failure Code		String Displayed	Description
SPN	FMI		
91	4	Thr Pos Sns Volt LO	Throttle position sensor input voltage (low)
91	14	Thr Pos Sns Volt OOR	Throttle voltage (out of range)
94	1	FUEL DELIV PRS LO LO	Engine fuel delivery pressure is below the low low threshold
94	3	Fuel Pmp Prs Volt HI	Fuel pump pressure input voltage (high)
94	4	Fuel Pmp Prs Volt LO	Fuel pump pressure input voltage (low)
94	17	Fuel Pressure LO	Fuel supply pressure (low least severe)
97	3	Water In FI Volt HI	Water in fuel signal voltage high
97	4	Water In FI Volt LO	Water in fuel signal voltage low
97	16	Water in Fuel	Water in fuel detected
98	#	ENG OIL LEVEL	Caption used on front panel for display of J1939 parameter
99	#	OIL FILTER DIFF PRESS	Caption string for oil filter differential pressure parameter
100	1	ENG OIL PRESS LO LO	Engine oil pressure is below the LOW LOW threshold
100	3	Oil Prs Snsr Volt HI	Oil pressure sensor input voltage (high)
100	4	Oil Prs Snsr Volt LO	Oil pressure sensor input voltage (low)
100	17	ENG OIL PRESS LO	Engine oil pressure is below the LOW threshold
100	18	Oil Prs Snsr Volt MLO	Oil pressure sensor input voltage (moderately low)
100	31	Oil Pressure INVLD	Oil pressure (invalid)
101	#	CRANKCASE PRESSURE	Caption string for crankcase pressure
102	2	Manifld Air Prs INVD	Manifold air pressure invalid
102	3	Mnflid AirP SnsVlt HI	Manifold air pressure sensor input voltage high
102	4	Mnflid AirP SnsVlt LO	Manifold air pressure sensor input voltage low
103	0	Trbo Overspd Severe	Turbo overspeed (most severe)
103	2	Trbo Speed MisMatch	Turbo speed (mismatch)
103	5	Trbo Spd Sns Curr LO	Turbo speed sensor current (low)
103	6	Trbo Spd Sns Curr HI	Turbo speed sensor current (high)
103	8	Trbo Speed INVLD	Turbo speed (invalid)
103	31	Trbo Speed MISSING	Turbo speed (missing)
105	0	EGR Mixed Air Tmp HI	Exhaust gas recirculation mixed air high (least severe)

Failure Code		String Displayed	Description
SPN	FMI		
105	3	EGR Air Temp Vlt HI	Exhaust gas recirculation mixed air temp voltage (high)
105	4	EGR Air Temp Vlt LO	Exhaust gas recirculation mixed air temp voltage (low)
105	15	EGR Mixed Air Tmp HI	Exhaust gas recirculation mixed air high (least severe)
105	16	EGR MxdAir Tmp MHI	Exhaust gas recirculation mixed air temp (moderately high)
107	0	Air Filt Restricted	Air filter restriction (high)
108	2	Barometric Prs INVLD	Barometric pressure (invalid)
108	31	Barometric Prs ERR	Barometric pressure (error)
109	1	ENG COOLNT PRS LO LO	Engine coolant pressure is below the LOW LOW threshold
109	17	ENG COOLANT PRS LO	Engine coolant pressure is below the LOW threshold
110	0	ENG COOLNT TMP HI HI	Engine coolant temperature is above the HIGH HIGH threshold
110	3	Cool Tmp Sns Volt HI	Coolant temp sensor input voltage (high)
110	4	Cool Tmp Sns Volt LO	Coolant temp sensor input voltage (low)
110	15	ENG COOLANT TEMP HI	Engine coolant temperature is above the HIGH threshold
110	16	Cool Temp MHI	Coolant temp sensor input (moderately high)
110	17	Cool Temp LO	Coolant temp sensor input (low least severe)
111	1	Coolnt Lvl LO	Coolant level (low)
111	17	ENG COOLANT LVL LO	Engine coolant level is below the LOW threshold
111	#	LOW COOL LEVEL	Low coolant level string used in event log and/or alarm and pre-alarm annunciation
157	3	Fuel Rail Prs Vlt HI	Fuel rail pressure input voltage (high)
157	4	Fuel Rail Prs Vlt LO	Fuel rail pressure input voltage (low)
157	10	Fuel Rail Prs LOSS	Fuel rail pressure loss detected
157	17	Fuel RI Prs NOT DEV	Fuel rail pressure not developed
158	0	KSW BATT VOLTS HI HI	Key switch battery potential is above the HIGH HIGH threshold
158	1	KSW BATT VOLTS LO LO	Key switch battery potential is below the LOW LOW threshold

Failure Code		String Displayed	Description
SPN	FMI		
158	15	KSW BATT VOLTS HI	Key switch battery potential is above the HIGH threshold
158	17	KSW BATT VOLTS LO	Key switch battery potential is below the LOW threshold
168	#	LOW BATT VOLT	Low battery voltage string used in event log and/or alarm and pre-alarm annunciation
174	0	Fuel Temp EXT HI	Fuel temp (extremely high)
174	3	Fuel Tmp Sns Volt HI	Fuel temp sensor input voltage (high)
174	4	Fuel Tmp Sns Volt LO	Fuel temp sensor input voltage (low)
174	16	Fuel Temp MHI	Fuel temp (moderately high)
175	#	ENG OIL TEMP	Caption used on front panel for Display of J1939 Parameter
188	17	SPEED AT IDLE LO	Metering string for ECU trouble code metering indicates engine idle speed is below the LOW threshold
189	0	Engine Spd DERATE	Engine speed derate
190	0	Engine OvrSpd EXTRM	Engine overspeed (extreme)
190	1	ENGINE SPEED LOW	Engine speed is below the LOW threshold
190	16	Engine OvrSpd MODRT	Engine overspeed (moderate)
190	17	SPEED AT IDLE LO	Engine idle speed is below the LOW threshold
190	#	ENGINE SPEED	Caption used on front panel for display of J1939 parameter
237	2	VIN Data MisMatch	VIN data mismatch with other controllers
412	0	EGR Temp EXT HI	Exhaust gas recirculation temp (extremely high)
412	3	EGR Temp In Vlt HI	Exhaust gas recirculation temp input voltage (high)
412	4	EGR Temp In Vlt LO	Exhaust gas recirculation temp input voltage (low)
412	16	EGR Temp MHI	Exhaust gas recirculation temp (moderately high)
520	#	RETARDER % TORQUE	Caption string for retarder % torque
563	#	ABS ACTIVE	Caption string for antilock brake system (abs) active
611	3	Inj Short to PWR	Injector wiring shorted to power
611	4	Inj Short to GND	Injector wiring shorted to ground
624	#	DIAGNOSTIC LAMP	Caption string for diagnostic lamp

Failure Code		String Displayed	Description
SPN	FMI		
627	1	Inj Sply Vlt Problm	Injector supply voltage problem
627	16	ECU Power Volt HI	ECU power high voltage
627	18	ECU Power Volt LO	ECU power low voltage
627	13	ECU ERROR	ECU error
630	#	ECU INTERNAL ERROR	Caption string for ECU internal error
636	2	Pump Pos Sns Noisy	Pump position sensor input noise
636	5	Pump Pos Sns Curr LO	Pump position sensor current (low)
636	6	Pump Pos Sns Curr HI	Pump position sensor current (high)
636	8	Pump Pos Sns In MSNG	Pump position sensor input missing
636	10	Pump Pos Sns In ERR	Pump position sensor input pattern error
637	2	Crank Pos Sns Noisy	Crank position input noise
637	5	Crank Pos Sns Curr LO	Crank position sensor current (low)
637	6	Crank Pos Sns Curr HI	Crank position sensor current (high)
637	7	Crnk/Pmp Pos Tmg OOS	Crank/pump position timing moderately out of sync
637	8	Crank Pos Sns MSNG	Crank position missing
637	10	Crank Pos Sns In ERR	Crank position input pattern error
639	#	J1939 NETWORK 1	Caption string for J1939 network number 1
641	4	Trbo Actuator ERR	Turbo actuator error
641	12	ECU/Trbo Comm ERR	ECU/turbo communication error
641	13	TrboAct Lrnd Val ERR	Turbo actuator learned value error
641	16	Trbo Act Temp MHI	Turbo actuator temp (moderately high)
651	2	Cyl 1 EUI PN INVLD	Cylinder #1 EUI part number (invalid)
651	5	Cyl 1 EUI Ckt OPEN	Cylinder #1 EUI circuit (open)
651	6	Cyl 1 EUI Ckt SHORT	Cylinder #1 EUI circuit (shorted)
651	7	Cyl 1 EUI Ckt MECH FL	Cylinder #1 EUI circuit (mechanical failure)
651	13	Cyl 1 EUI QR INVLD	Cylinder #1 EUI circuit QR code (invalid)
651	#	CYLINDER 1 INJECTOR	Caption string for cylinder 1 injector
652	2	Cyl 2 EUI PN INVLD	Cylinder #2 EUI part number (invalid)
652	5	Cyl 2 EUI Ckt OPEN	Cylinder #2 EUI circuit (open)
652	6	Cyl 2 EUI Ckt SHORT	Cylinder #2 EUI circuit (shorted)
652	7	Cyl 2 EUI Ckt MECH FL	Cylinder #2 EUI circuit (mechanical failure)

Failure Code		String Displayed	Description
SPN	FMI		
652	13	Cyl 2 EUI QR INVLD	Cylinder #2 EUI circuit QR code (invalid)
652	#	CYLINDER 2 INJECTOR	Caption string for cylinder 2 injector
653	2	Cyl 3 EUI PN INVLD	Cylinder #3 EUI part number (invalid)
653	5	Cyl 3 EUI Ckt OPEN	Cylinder #3 EUI circuit (open)
653	6	Cyl 3 EUI Ckt SHORT	Cylinder #3 EUI circuit (shorted)
653	7	Cyl 3 EUI Ckt MECH FL	Cylinder #3 EUI circuit (mechanical failure)
653	13	Cyl 3 EUI QR INVLD	Cylinder #3 EUI circuit QR code (invalid)
653	#	CYLINDER 3 INJECTOR	Caption string for cylinder 3 injector
654	2	Cyl 4 EUI PN INVLD	Cylinder #4 EUI part number (invalid)
654	5	Cyl 4 EUI Ckt OPEN	Cylinder #4 EUI circuit (open)
654	6	Cyl 4 EUI Ckt SHORT	Cylinder #4 EUI circuit (shorted)
654	7	Cyl 4 EUI Ckt MECH FL	Cylinder #4 EUI circuit (mechanical failure)
654	13	Cyl 4 EUI QR INVLD	Cylinder #4 EUI circuit QR code (invalid)
654	#	CYLINDER 4 INJECTOR	Caption string for cylinder 4 injector
655	2	Cyl 5 EUI PN INVLD	Cylinder #5 EUI part number (invalid)
655	5	Cyl 5 EUI Ckt OPEN	Cylinder #5 EUI circuit (open)
655	6	Cyl 5 EUI Ckt SHORT	Cylinder #5 EUI circuit (shorted)
655	7	Cyl 5 EUI Ckt MECH FL	Cylinder #5 EUI circuit (mechanical failure)
655	13	Cyl 5 EUI QR INVLD	Cylinder #5 EUI circuit QR code (invalid)
655	#	CYLINDER 5 INJECTOR	Caption string for cylinder 5 injector
656	2	Cyl 6 EUI PN INVLD	Cylinder #6 EUI part number (invalid)
656	5	Cyl 6 EUI Ckt OPEN	Cylinder #6 EUI circuit (open)
656	6	Cyl 6 EUI Ckt SHORT	Cylinder #6 EUI circuit (shorted)
656	7	Cyl 6 EUI Ckt MECH FL	Cylinder #6 EUI circuit (mechanical failure)
656	13	Cyl 6 EUI QR INVLD	Cylinder #6 EUI circuit QR code (invalid)
656	#	CYLINDER 6 INJECTOR	Caption string for cylinder 6 injector
657	#	CYLINDER 7 INJECTOR	Caption string for cylinder 7 injector
658	#	CYLINDER 8 INJECTOR	Caption string for cylinder 8 injector
659	#	CYLINDER 9 INJECTOR	Caption string for cylinder 9 injector
660	#	CYLINDER 10 INJECTOR	Caption string for cylinder 10 injector
661	#	CYLINDER 11 INJECTOR	Caption string for cylinder 11 injector

Failure Code		String Displayed	Description
SPN	FMI		
662	#	CYLINDER 12 INJECTOR	Caption string for cylinder 12 injector
663	#	CYLINDER 13 INJECTOR	Caption string for cylinder 13 injector
664	#	CYLINDER 14 INJECTOR	Caption string for cylinder 14 injector
665	#	CYLINDER 15 INJECTOR	Caption string for cylinder 15 injector
666	#	CYLINDER 16 INJECTOR	Caption string for cylinder 16 injector
667	#	CYLINDER 17 INJECTOR	Caption string for cylinder 17 injector
668	#	CYLINDER 18 INJECTOR	Caption string for cylinder 18 injector
669	#	CYLINDER 19 INJECTOR	Caption string for cylinder 19 injector
670	#	CYLINDER 20 INJECTOR	Caption string for cylinder 20 injector
671	#	CYLINDER 21 INJECTOR	Caption string for cylinder 21 injector
672	#	CYLINDER 22 INJECTOR	Caption string for cylinder 22 injector
673	#	CYLINDER 23 INJECTOR	Caption string for cylinder 23 injector
674	#	CYLINDER 24 INJECTOR	Caption string for cylinder 24 injector
676	#	ENG GLOW PLUG RELAY	Caption string for engine glow plug relay
677	#	ENGINE START RELAY	Caption string for engine start relay
701	#	AUX I/O 1	Caption string for auxiliary I/O 1
702	#	AUX I/O 2	Caption string for auxiliary I/O 2
703	#	AUX I/O 3	Caption string for auxiliary I/O 3
704	#	AUX I/O 4	Caption string for auxiliary I/O 4
705	#	AUX I/O 5	Caption string for auxiliary I/O 5
706	#	AUX I/O 6	Caption string for auxiliary I/O 6
707	#	AUX I/O 7	Caption string for auxiliary I/O 7
708	#	AUX I/O 8	Caption string for auxiliary I/O 8
709	#	AUX I/O 9	Caption string for auxiliary I/O 9
710	#	AUX I/O 10	Caption string for auxiliary I/O 10
711	#	AUX I/O 11	Caption string for auxiliary I/O 11
712	#	AUX I/O 12	Caption string for auxiliary I/O 12
713	#	AUX I/O 13	Caption string for auxiliary I/O 13
714	#	AUX I/O 14	Caption string for auxiliary I/O 14
715	#	AUX I/O 15	Caption string for auxiliary I/O 15
716	#	AUX I/O 16	Caption string for auxiliary I/O 16

Failure Code		String Displayed	Description
SPN	FMI		
898	2	REQ SPD DATA ERRATIC	Speed demand data is erratic
898	9	Spd/Trq Msg INVLD	Vehicle speed/torque message invalid
898	#	ENGINE REQSTED SPEED	Caption string for engine requested speed
923	#	PWM OUTPUT	Caption string for engine PWM output
970	2	Aux Eng SD SW INVLD	Auxiliary engine shutdown switch (invalid)
970	31	Aux Eng SD SW ACTV	Auxiliary engine shutdown switch active
971	31	Eng Derate SW ACTV	External engine derate switch active
975	#	FAN SPEED	Caption string for engine fan speed
1072	#	ENG BRAKE OUTPUT 1	Caption string for engine brake output 1
1074	#	ENG EXHAUST BRAKE OUT	Caption string for engine exhaust brake output
1075	5	Fuel TR Pump Curr LO	Fuel transfer pump current (low)
1075	6	Fuel TR Pump Curr HI	Fuel transfer pump current (high)
1075	12	Fuel TR Pump ERR	Fuel transfer pump (error)
1079	#	SENSOR SUPPLY VOLTS 1	Caption string for sensor supply voltage 1
1080	3	Snsr Supp 1 Volt LO	Sensor supply 1 voltage (low)
1080	4	Snsr Supp 1 Volt HI	Sensor supply 1 voltage (high)
1080	#	SENSOR SUPPLY VOLTS 2	Caption string for sensor supply voltage 2
1081	#	ENG WAIT TO START LMP	Caption string for engine wait to start lamp
1109	31	Eng Shutdown WARNING	Engine shutdown warning
1109	#	EPS SHUTDN APPROACHG	Caption string for indication that engine protective system shutdown is approaching
1110	31	Eng Prot Shutdown	Engine protection shutdown
1136	0	ECU Temp EXT HI	ECU temperature (extremely high)
1136	15	ENG ECU TEMP HI	ECU temperature has exceeded the HIGH level
1136	16	ECU Temp MHI	ECU temperature (moderately high)
1172	3	Trbo Cmp Tmp Volt HI	Turbo compressor inlet temp input voltage (high)
1172	4	Trbo Cmp Tmp Volt LO	Turbo compressor inlet temp input voltage (low)
1172	16	Trbo Cmp In Tmp MHI	Turbo compressor inlet temp (moderately high)
1180	0	Trbo Trbn Tmp EXT HI	Turbo turbine inlet temp (extremely high)
1180	16	Trbo Trbn In Tmp MHI	Turbo turbine inlet temp (moderately high)
1231	#	J1939 NETWORK 2	Caption string for J1939 network number 2
1235	#	J1939 NETWORK 3	Caption string for J1939 network number 3

Failure Code		String Displayed	Description
SPN	FMI		
1237	#	ENG SHUTDN ORIDE SW	Caption string for engine shutdown override switch
1322	#	MULTI CYL MISFIRE	Caption String for misfire detected on multiple engine cylinders
1323	#	MISFIRE CYLINDER 1	Caption string for misfire detected on a single engine cylinder
1324	#	MISFIRE CYLINDER 2	Caption string for misfire detected on a single engine cylinder
1325	#	MISFIRE CYLINDER 3	Caption string for misfire detected on a single engine cylinder
1326	#	MISFIRE CYLINDER 4	Caption string for misfire detected on a single engine cylinder
1327	#	MISFIRE CYLINDER 5	Caption string for misfire detected on a single engine cylinder
1328	#	MISFIRE CYLINDER 6	Caption string for misfire detected on a single engine cylinder
1329	#	MISFIRE CYLINDER 7	Caption string for misfire detected on a single engine cylinder
1330	#	MISFIRE CYLINDER 8	Caption string for misfire detected on a single engine cylinder
1331	#	MISFIRE CYLINDER 9	Caption string for misfire detected on a single engine cylinder
1332	#	MISFIRE CYLINDER 10	Caption string for misfire detected on a single engine cylinder
1333	#	MISFIRE CYLINDER 11	Caption string for misfire detected on a single engine cylinder
1334	#	MISFIRE CYLINDER 12	Caption string for misfire detected on a single engine cylinder
1335	#	MISFIRE CYLINDER 13	Caption string for misfire detected on a single engine cylinder
1336	#	MISFIRE CYLINDER 14	Caption string for misfire detected on a single engine cylinder
1337	#	MISFIRE CYLINDER 15	Caption string for misfire detected on a single engine cylinder
1338	#	MISFIRE CYLINDER 16	Caption string for misfire detected on a single engine cylinder
1339	#	MISFIRE CYLINDER 17	Caption string for misfire detected on a single engine cylinder

Failure Code		String Displayed	Description
SPN	FMI		
1340	#	MISFIRE CYLINDER 18	Caption string for misfire detected on a single engine cylinder
1341	#	MISFIRE CYLINDER 19	Caption string for misfire detected on a single engine cylinder
1342	#	MISFIRE CYLINDER 20	Caption string for misfire detected on a single engine cylinder
1343	#	MISFIRE CYLINDER 21	Caption string for misfire detected on a single engine cylinder
1344	#	MISFIRE CYLINDER 22	Caption string for misfire detected on a single engine cylinder
1345	#	MISFIRE CYLINDER 23	Caption string for misfire detected on a single engine cylinder
1346	#	MISFIRE CYLINDER 24	Caption string for misfire detected on a single engine cylinder
1347	3	Pump Ctrl Vlv Curr HI	Pump control valve current (high)
1347	5	Pmp Ctrl Vlv C MSMCH	Pump control valve current (mismatch)
1347	7	Fuel RI Prs Ctrl ERR	Fuel rail pressure control (error)
1569	31	Fuel Derate	Fuel derate
1638	#	HYDRAULIC TEMP	Caption string for hydraulic temperature
1639	1	Fan Speed Zero	Fan speed detected (zero)
1639	16	Fan Speed HI	Fan speed detected (high)
1639	18	Fan Speed LO	Fan speed detected (low)
2000	13	Security Violation	Security violation
2005	9	TSC CAN Msg NT RCV	TSC CAN message not received
2030	9	AC Clutch Msg NT RCV	A/C Clutch Status CAN Message Not Received
2071	9	Tr Oil Can Msg NT RCV	Trans. oil, tier size, vehicle speed can message not received
2629	0	TRBO 1 OUT TMP HI HI	Turbocharger 1 outlet pressure is above the HIGH HIGH threshold
2629	15	TURBO 1 OUT TMP HI	Turbocharger 1 outlet pressure is above the HIGH threshold
2630	0	EGR FrAir Tmp EXT HI	Exhaust gas recirculation fresh air temp (extremely high)
2630	3	EGR FrAir Tmp Vlt HI	Exhaust gas recirculation fresh air temp input voltage (high)

Failure Code		String Displayed	Description
SPN	FMI		
2630	4	EGR FrAir Tmp Vlt LO	Exhaust gas recirculation fresh air temp input voltage (low)
2630	15	EGR FrAir Tmp HI	Exhaust gas recirculation fresh air temp (high least severe)
2630	16	EGR FrAir Tmp MHI	Exhaust gas recirculation fresh air temp (moderately high)
2634	#	POWER RELAY	Caption string for main power relay
2659	2	EGR Flo/Tmp MISMATCH	Exhaust gas recirculation flow/temp mismatch
2659	15	EGR Flo Rt High	Exhaust gas recirculation flow rate (high least severe)
2659	17	EGR Flo Rt LO	Exhaust gas recirculation flow rate (low least severe)
2790	16	Trbo Cmp Out Tmp HI	Turbo compressor outlet temp (moderately high)
2791	2	EGR Vlv Pos InVld	Exhaust gas recirculation valve position invalid
2791	3	EGRVlv Pos In Vlt HI	Exhaust gas recirculation valve position input voltage (high)
2791	4	EGRVlv Pos In Vlt LO	Exhaust gas recirculation valve position input voltage (low)
2791	13	EGR Vlv Control ERR	Exhaust gas recirculation valve control error
2791	31	EGR Valve Cal ERR	Exhaust gas recirculation valve calibration error
2791	#	EGR VALVE CONTROL	Caption string for EGR valve control
2795	7	Trbo Act Pos MSMATCH	Turbo actuator position mismatch
3719	0	DPF SOOT LVL EXT HI	String for diagnostic trouble code indicating diesel particulate filter soot level high - most severe level
3719	15	DPF SOOT LVL HI	String for diagnostic trouble code indicating diesel particulate filter soot level high - least severe level
3719	16	DPF SOOT LVL MOD HI	String for diagnostic trouble code indicating diesel particulate filter soot level high - moderately severe level
520837	1	STARTER SPEED LO LO	Starter Speed is below the LOW LOW threshold
820838	1	RUN UP SPEED LO LO	Run Up Speed is below the LOW LOW threshold
522192	12	MTU ENGINE BAD	Component failure of the MTU engine control ECU
523212	#	ENGPRT CAN MSG	Caption string for CANBus message
523216	#	PREHTENCMD CAN MSG	Caption string for CANBus message

Failure Code		String Displayed	Description
SPN	FMI		
523218	#	RxCCVS CAN MSG	Caption string for CANBus message
523222	#	TC01 CAN MSG	Caption string for CANBus message
523238	#	SWTOUT CAN MSG	Caption string for CANBus message
523239	#	DECV1 CAN MSG	Caption string for CANBus message
523240	#	FUNMODCTL CAN MSG	Caption string for CANBus message
523350	#	CYL BANK 1 INJECTORS	Caption string for cylinder bank 1 injectors
523351	#	CYL BANK 1 INJECTORS	Caption string for cylinder bank 1 injectors
523352	#	CYL BANK 2 INJECTORS	Caption string for cylinder bank 2 injectors
523353	#	CYL BANK 2 INJECTORS	Caption string for cylinder bank 2 injectors
523354	#	ECU ERROR	String for diagnostic trouble code indicating ECU error
523355	#	ECU ERROR	String for diagnostic trouble code indicating ECU error
523370	#	RAIL PRESSURE	Caption string for rail pressure
523420	#	ECU ERROR	String for diagnostic trouble code indicating ECU error
523450	#	MULTI STATE SWITCH 1	Caption string for multi state switch 1
523451	#	MULTI STATE SWITCH 2	Caption string for multi state switch 2
523452	#	MULTI STATE SWITCH 3	Caption string for multi state switch 3
523470	#	RAIL PRESSURE LMT VLV	Caption string for rail pressure limit valve
523490	#	ECU ERROR	String for diagnostic trouble code indicating ECU error
523500	#	CAN MSG TIMEOUT	Caption string indicating CAN message timeout has occurred
523550	#	ECU ERROR	String for diagnostic trouble code indicating ECU error
523561	#	INJECTN PERIOD CYL 1	Caption string for single cylinder injection period
523562	#	INJECTN PERIOD CYL 2	Caption string for single cylinder injection period
523563	#	INJECTN PERIOD CYL 3	Caption string for single cylinder injection period
523564	#	INJECTN PERIOD CYL 4	Caption string for single cylinder injection period
523565	#	INJECTN PERIOD CYL 5	Caption string for single cylinder injection period
523566	#	INJECTN PERIOD CYL 6	Caption string for single cylinder injection period
523567	#	INJECTN PERIOD CYL 7	Caption string for single cylinder injection period
523568	#	INJECTN PERIOD CYL 8	Caption string for single cylinder injection period

Failure Code		String Displayed	Description
SPN	FMI		
523600	#	ECU ERROR	String for diagnostic trouble code indicating ECU error
523601	#	ECU ERROR	String for diagnostic trouble code indicating ECU error
523602	#	FAN SPEED	Caption string for engine fan speed
523604	#	RXENGTMP CAN MSG	Caption string for CANBus message
523605	#	TSC1-AE MSG MISSING	Caption string for CANBus message
523606	#	TSC1-AR MSG MISSING	Caption string for CANBus message
523607	#	TSC1-DE MSG MISSING	Caption string for CANBus message
523608	#	TSC1-DR MSG MISSING	Caption string for CANBus message
523609	#	TSC1-PE MSG MISSING	Caption string for CANBus message
523610	#	TSC1-VE MSG MISSING	Caption string for CANBus message
523611	#	TSC1-VR MSG MISSING	Caption string for CANBus message
523612	#	ECU ERROR	String for diagnostic trouble code indicating ECU error
523613	#	RAIL PRESSURE	Caption string for rail pressure
523615	#	METERING UNIT VALVE	Caption string for metering unit valve
523617	#	ECU ERROR	String for diagnostic trouble code indicating ECU error

15 Factory-Installed Options

This machine may be equipped with one or more of the following factory-installed options. To verify if any of these options are installed on your machine, contact Wacker Neuson Corporation at 1-800-770-0957. A nameplate listing the model number, item number, and serial number is attached to each unit. Please have this information available when contacting Wacker Neuson Corporation.

The illustrations shown in this chapter represent typical installations. The factory-installed options on your machine may look different.

15.1 Battery Charger

An optional battery charger **(a)** maintains the battery at peak power while the machine is turned off. Use of a battery charger is recommended when the generator is not operated on a regular basis. The battery charger prevents voltage drain and reduces the possibility of having to jump-start the engine after long periods of inactivity. Plug the cord into a 120V power supply.

Note: *Graphic is representative only. Your machine may vary.*

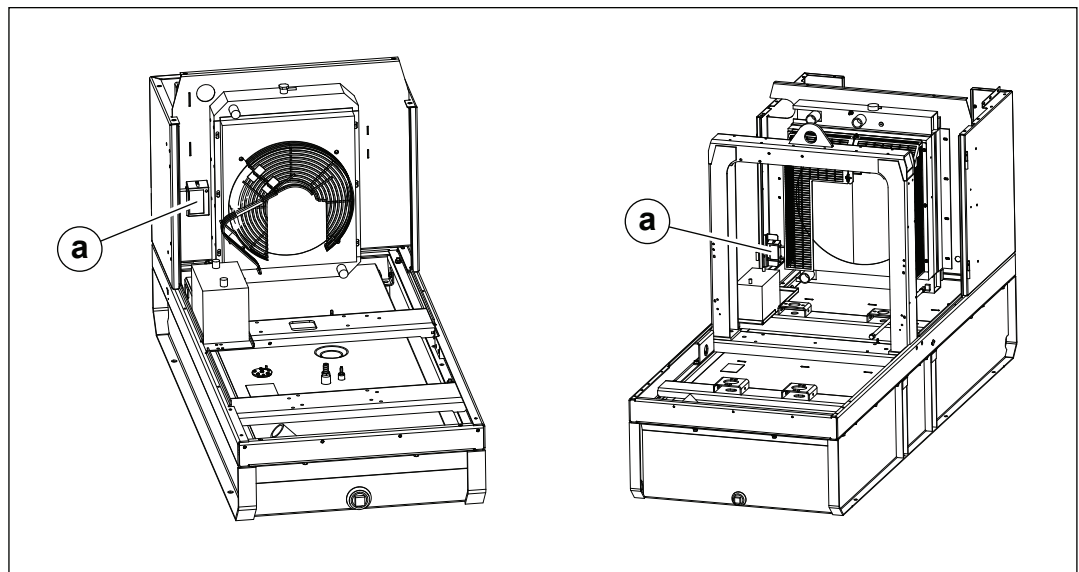

wc_gr012952

15.2 Lockable Battery Disconnect

A lockable ON/OFF switch is available which disconnects the battery. A padlock (not included) securely locks the switch in the OFF position. If equipped, the battery disconnect switch is mounted to the upper skid beneath the access door on either the right or left side of the machine.

Note: *Graphic is representative only. Your machine may vary.*

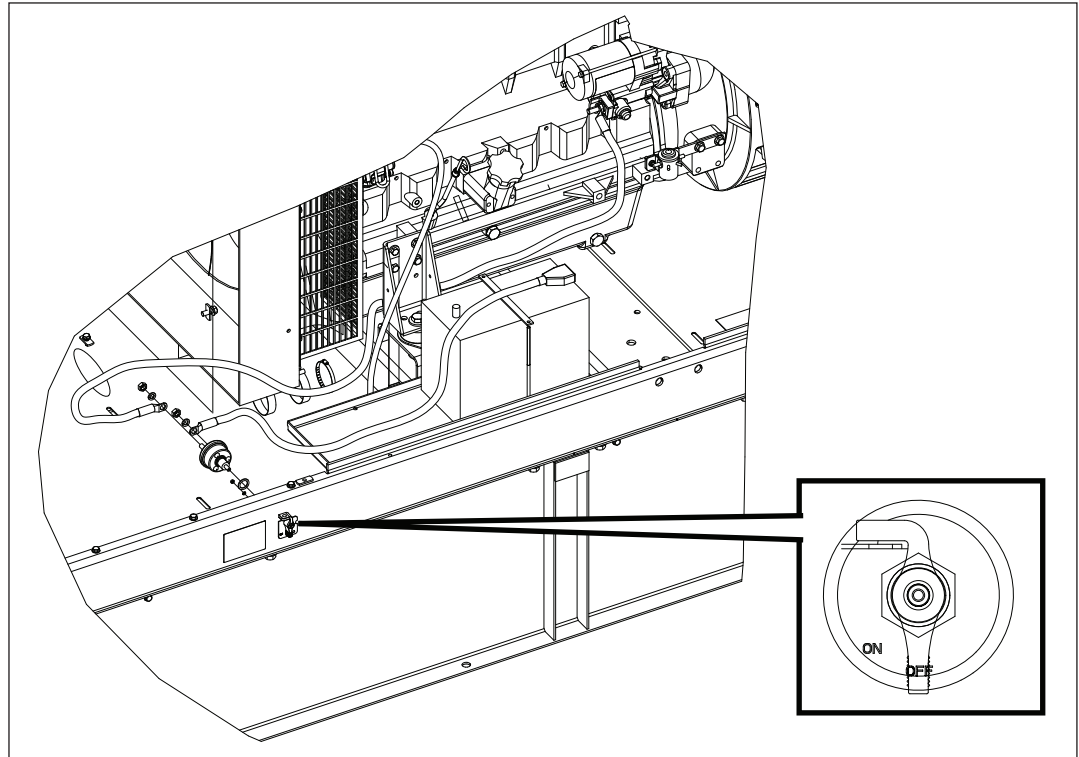

wc_gr012953

NOTICE: Do not use the battery disconnect switch while the engine is running. Damage to electrical components may occur.

15.3 Camlocks

A second optional outlet panel features camlock connectors for easy tool changes. Each connector is protected by a spring-loaded cover.

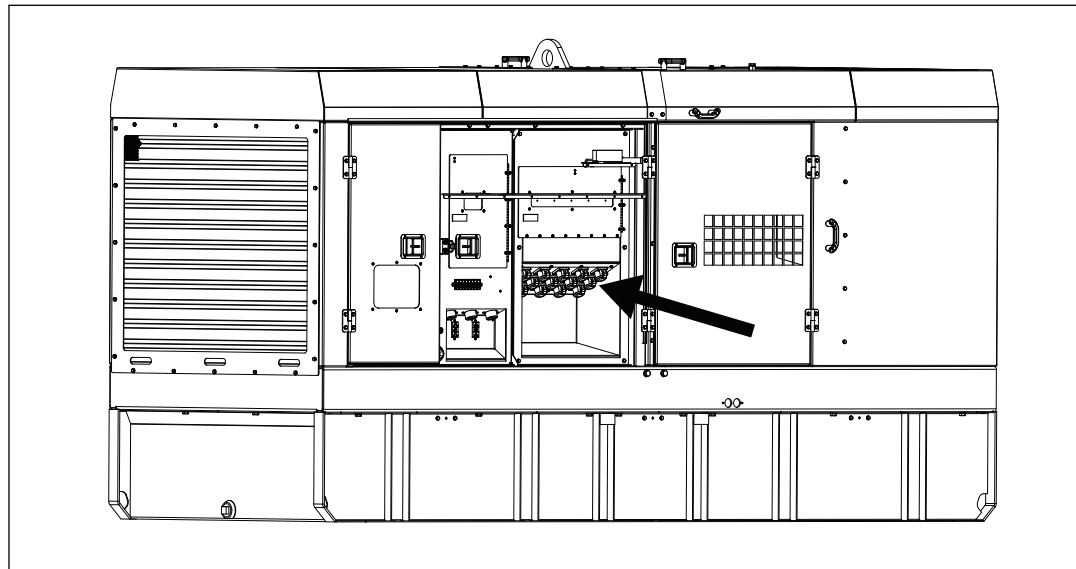

wc_gr012954

NOTICE: Separate overcurrent protection must be provided. Do not exceed 400 amps per receptacle.



WARNING

Electric shock hazard.

- ▶ Do not operate this machine with defective or missing guards, doors, or protective interlocks.

15.4 Containment System

Overspills and leaks are captured in the containment system (a). The containment system holds over 110% of the fluid contained in the machine.

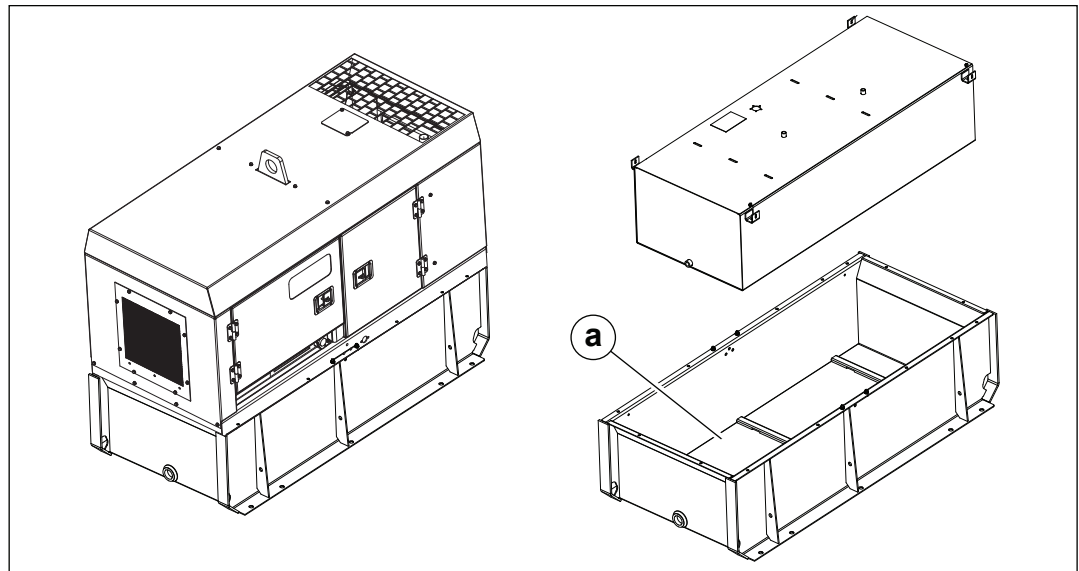

wc_gr012955

15.5 Extended Run Tank (ERT)

An extended run (fuel) tank (a) provides extended run time under a continuous full load. The long run time eliminates the need for daily refueling, saving money on fuel deliveries. The tank is fully fluid-contained and is ideal for remote or weekend running of equipment such as dewatering submersible pumps.

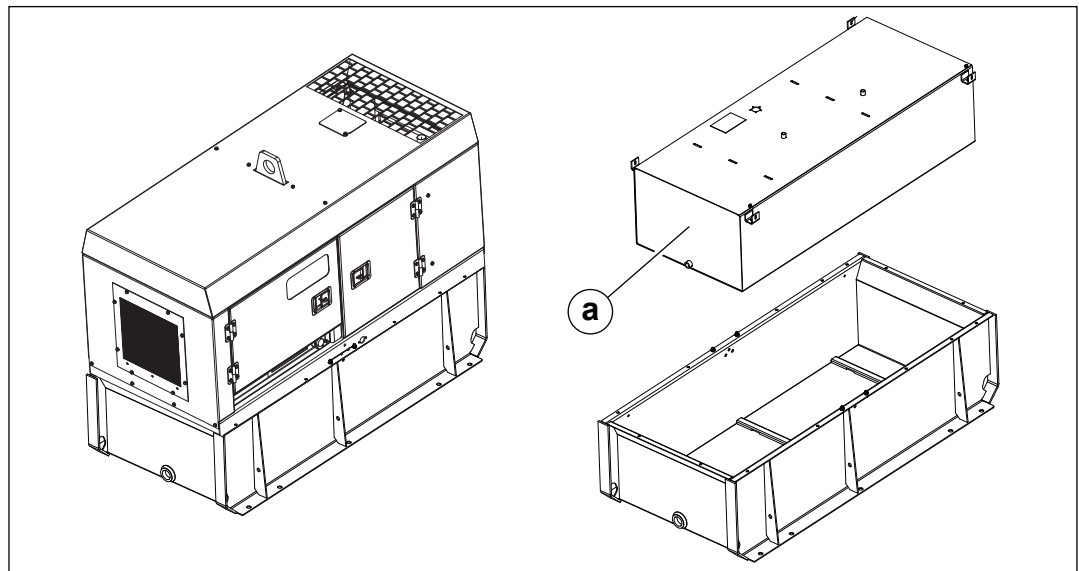

wc_gr012957

15.6 Engine Block Heater

The engine block heater option includes a block heater (a) with a cord (b). The function of the block heater is to heat the engine coolant/engine block to improve cold-weather engine starting. Plug the cord into a 120V power supply.

Note: *Graphic is representative only. Your machine may vary.*

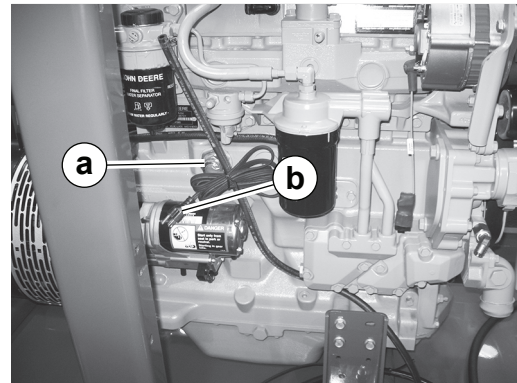

wc_gr012967

15.7 Cold-Weather Thermostat

The generator controller includes an integral heater. The heater turns on and off as needed when power is connected to the generator controller. The heater prevents damage to the generator controller in cold weather.

The function of the cold-weather thermostat is to connect power to the generator controller when the engine isn't running. When the temperature drops below approximately -30°C (-22°F), the thermostat closes and power is supplied to the generator controller.

NOTICE: When the generator controller is turned on, it draws power from the battery. Be sure to keep the battery charged when the generator is not in use.

The cold-weather thermostat (a) is mounted behind the generator control panel.

Note: *Graphic is representative only. Your machine may vary.*

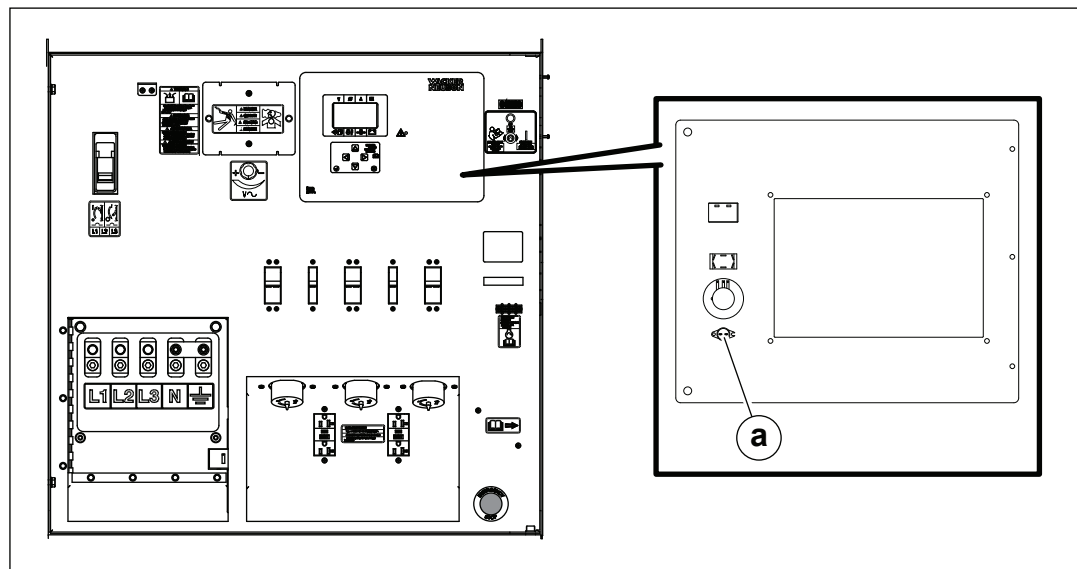

wc_gr012958

15.8 Low Coolant Shutdown

Background The low-coolant shutdown system consists of an electronic sensor that monitors coolant level. The sensor (**a**) is mounted to the radiator and wired into the ECM. The sensor probe (**b**) is submerged in radiator coolant.

Note: *Graphic is representative only. Your machine may vary.*

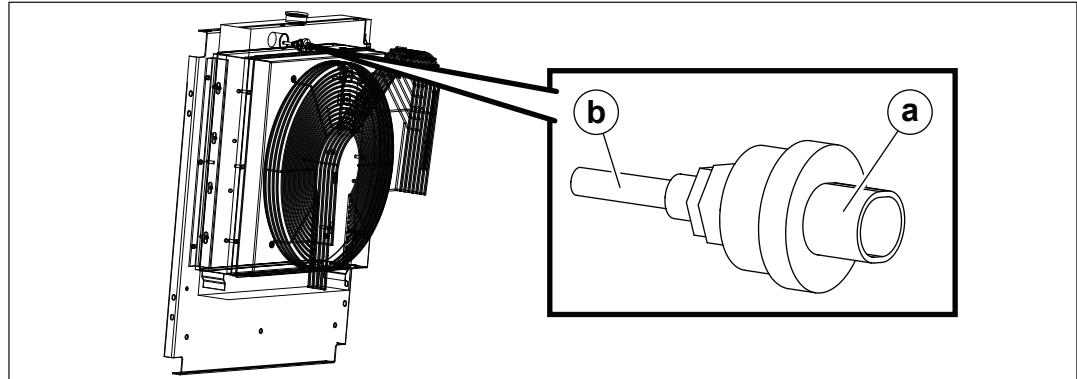

wc_gr012960

Function

If the probe senses no coolant, it sends a signal to the ECM. The ECM program includes a 10-second timer to protect from nuisance shutdowns. If after the ten seconds coolant levels are still sensed as being low, the ECM shuts down the engine. The ECM will then display "LOW COOL LEVEL". Allow the engine to cool before adding additional coolant.



WARNING

Burn hazard. Pressurized coolant is very hot and can cause serious burns.

- ▶ Do not remove the radiator cap while the engine is hot.

If it is necessary to open the radiator, only do so with the engine off, and only when coolant is cool enough to touch with bare hands. Slowly loosen the radiator cap to relieve pressure first, before removing it completely.

Note: *The sensor may be disabled by unplugging the wire harness. This action will not shut down the machine.*

15.9 Temperature-Activated Shutters

The shutters (a) are mounted to the top of the generator enclosure.

Note: *Graphic is representative only. Your machine may vary.*

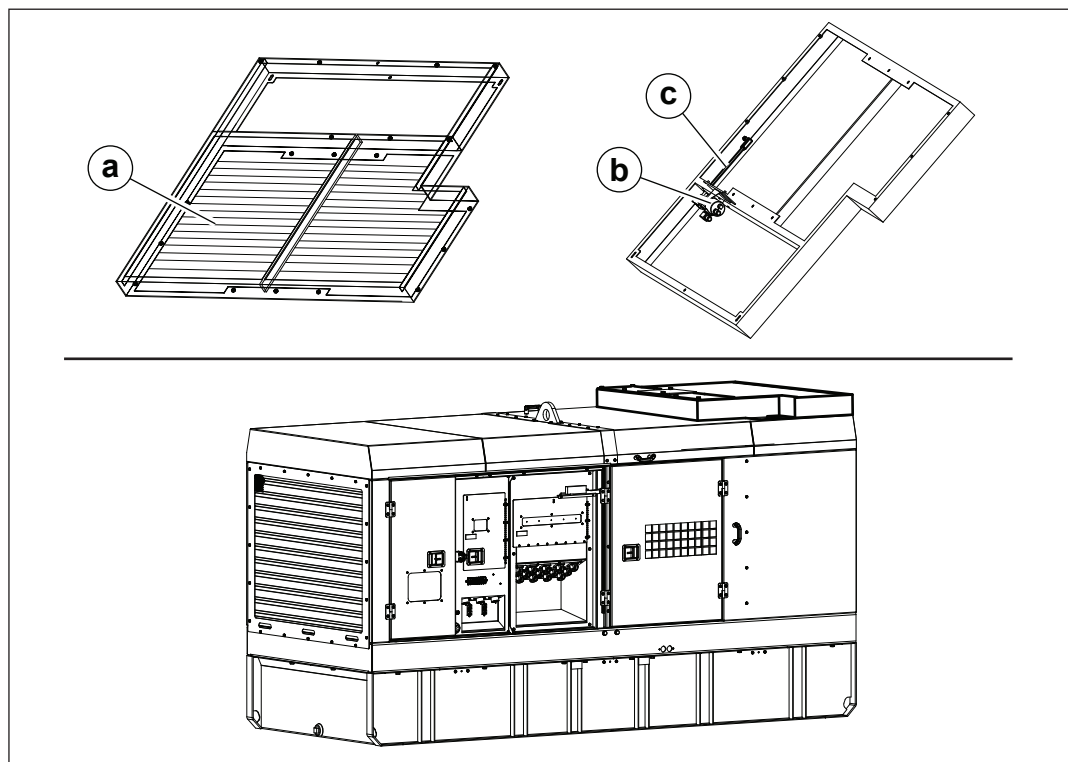

wc_gr012812

The shutters are designed to keep the engine compartment warm, thus increasing engine temperature during cold weather operation. The shutters are activated through a wax-pellet actuator (b) that is connected to the generator's cooling system. As radiator coolant warms, the wax-pellet actuator engages a linkage (c) that opens the shutters. As the coolant cools, the shutters close.

15.10 Positive Air Shutoff Valve

Description Diesel engines may occasionally continue to run even after the machine has been turned off. This “runaway” condition occurs when combustible intake air is drawn into the engine. Pressing the emergency stop switch alone will not stop a runaway engine.

Some models include a positive air shutoff valve **(a)**. Activating the positive air shutoff valve blocks the flow of air into the engine intake and stops the engine from running.

Note: *Graphic is representative only. Your machine may vary.*

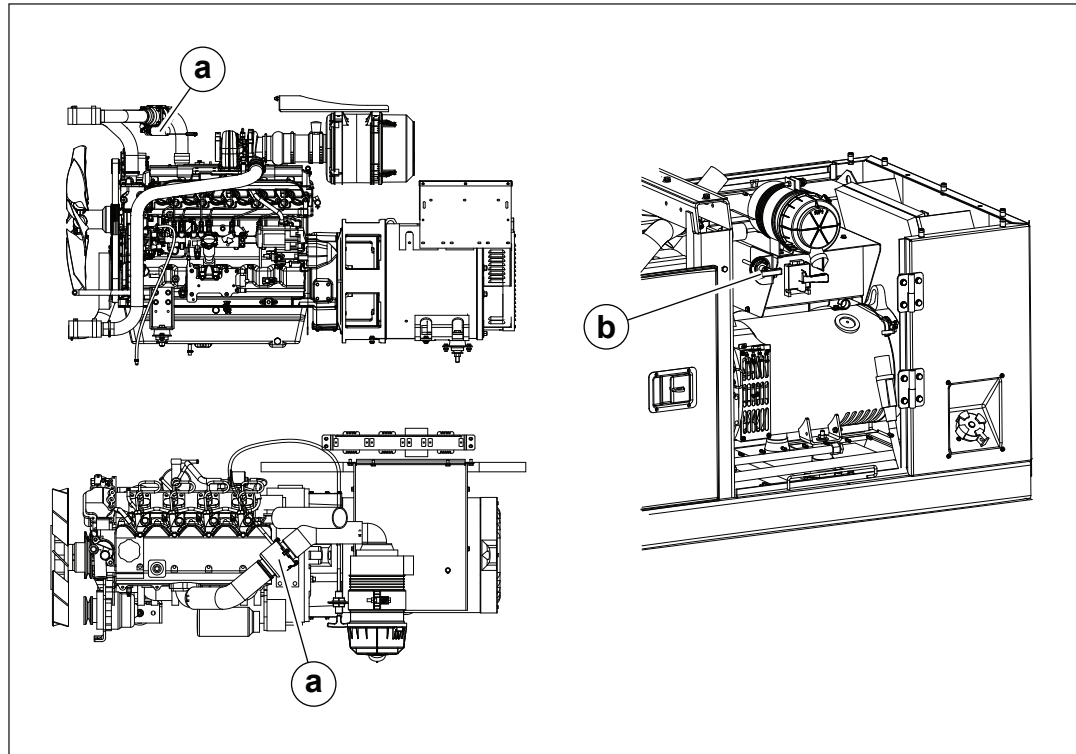

wc_gr012961

Operation To activate the positive air shutoff valve, pull the T-handle **(b)** located next to the voltage selector switch. The valve will reset automatically after activation.

15.11 Connecting an External Fuel Supply

Background Quick-disconnect fuel fittings allow an external fuel supply to be connected.

- Requirements**
- Engine stopped and cool to the touch
 - Fuel supply and return hoses with compatible quick-disconnect fittings

Note: Required fitting size is ISO 7241-1-Series B (Supply is 1/2 in. and return is 3/8 in.)

Procedure Perform the procedure below to connect the external fuel supply.



WARNING

Fire hazard. Improper connections or damaged hoses may leak flammable fuel.

- ▶ Ensure that all quick-disconnect fittings are properly seated before operating the machine.
- ▶ Make sure that fuel hoses are not kinked. Ensure that the hoses will not touch or rest upon hot surfaces while the machine is operating.

1. Connect the external feed hose at the external feed hose fitting (a).
2. Connect the external return hose at the external return hose fitting (b).

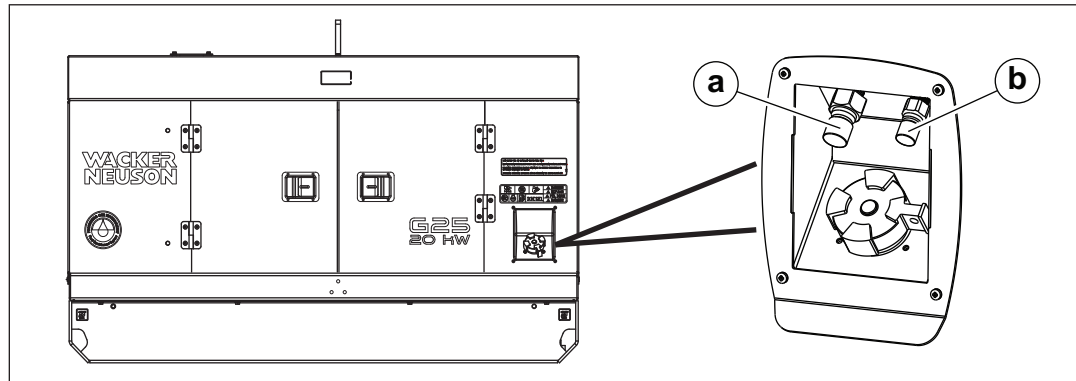

wc_gr013026

3. Move the fuel valve handle (e) from the up position (c) for internal fuel supply to the down position (d) for external fuel supply.

Note: Graphic is representative only. Your machine may vary.

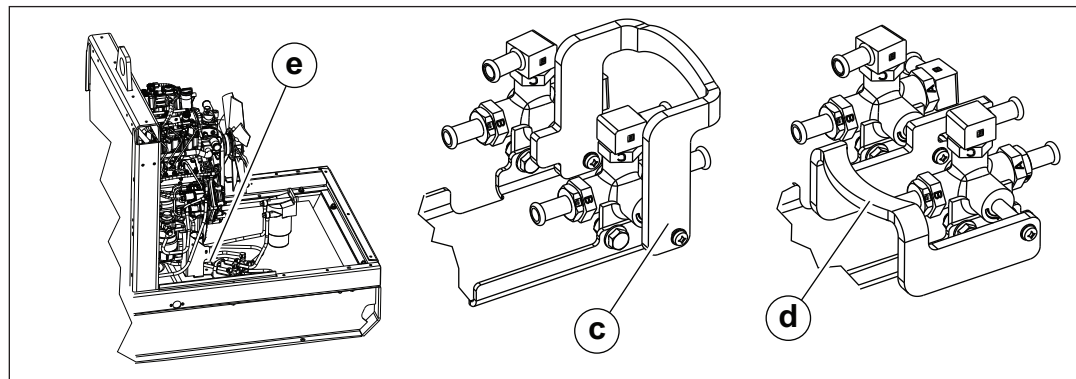

wc_gr013027

15.12 Lube Level Maintainer

Description The lube level maintainer system protects the engine from low oil levels by providing an additional 6-quart oil reservoir. Oil from the reservoir is gravity-fed from the oil reservoir (a) through the control valve (b) and into the engine oil pan as needed.

Note: *Graphic is representative only. Your machine may vary.*

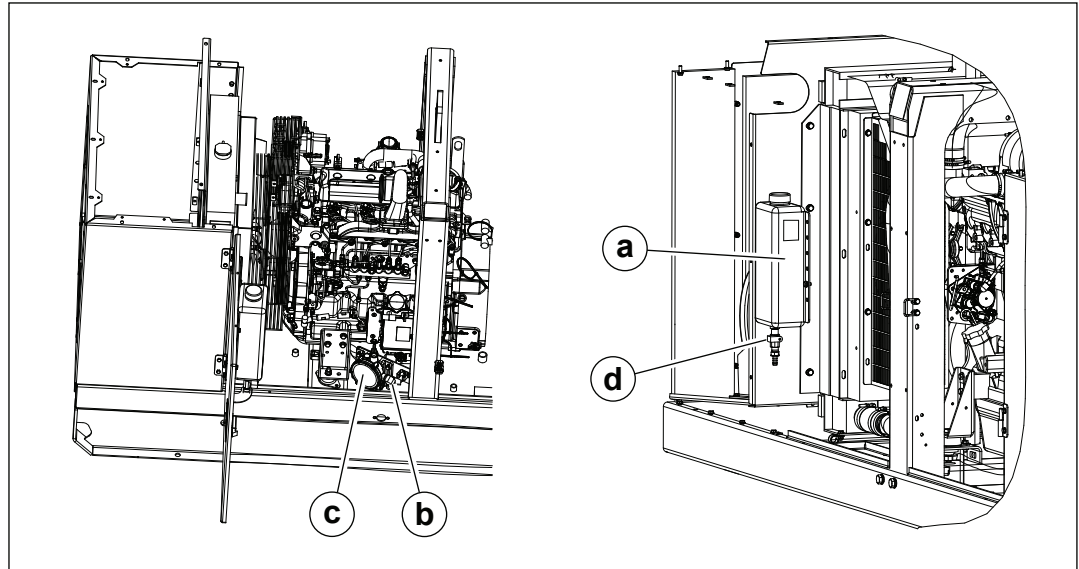

wc_gr012964

The valve includes a sightglass (c) through which the oil level can be seen. This oil level is the same as that measured by the engine dipstick. A float inside the valve detects low oil levels and opens the valve to supply the needed oil. The system is wired to the ECM and includes a low oil shutdown in case the oil in the reservoir is depleted.

Operation

If the engine shuts down due to low oil, the ECM will display “LOW OIL LEVEL”. Fill the engine and the additional oil reservoir with oil before placing the generator back into service.

NOTICE: To prevent overfilling the engine with oil, place the shutoff valve (d) in the closed position when moving or towing the generator. Once the generator is in position, open the valve.

16 General Maintenance



WARNING

A poorly maintained machine can malfunction, causing injuries or permanent damage to the machine.

- ▶ Keep the machine in safe operating condition by performing periodic maintenance and making repairs as needed.

16.1 Periodic Maintenance Schedule

The table below lists basic machine maintenance. Tasks designated with check marks ✓ may be performed by the operator. Tasks designated with square bullet points ■ require special training and equipment.

	Daily	Weekly	50 hours or 2 weeks	250 hours	600 hours or 12 months	Other
Conduct visual walk-around inspection.	✓					
Check exhaust system.		✓				
Drain containment system. (if equipped)			■			
Service the battery.				■		
Clean the machine inside and out.				■		
Grease axle.					■	
Check brake fluid level in trailer. ¹						■
Fill the radiator. ²						■
Replace the aftertreatment DEF dosing unit filter. ³ (if equipped)						■

¹ At least monthly.

² Every 2000 hours or 2 years.

³ Every 4500 hours or 3 years.

16.2 Maintaining the Emission Control System

For machines sold in North America:

Normal maintenance, replacement, or repair of emission control devices and systems may be performed by any repair establishment or individual; however, warranty repairs must be performed by a dealer/service center authorized by Wacker Neuson. The use of service parts that are not equivalent in performance and durability to authorized parts may impair the effectiveness of the emission control system and may have a bearing on the outcome of a warranty claim.

16.3 Preparing for Maintenance

Do not perform even routine service (oil/filter changes, cleaning, etc.) unless all electrical components are shut down. Use the checklist below to prepare this machine for maintenance.

- Set the start switch to OFF.
- Open the circuit breakers (set to the OFF position).
- Close the emergency stop switch (push in).
- Disconnect the negative terminal on the battery.
- Attach a "DO NOT START" sign to the control panel.
- If the unit is connected to a remote start or transfer switch, make sure the remote switch is also off and tagged.

16.4 Cleaning the Machine

When	As needed
Suggested cleaning materials	<ul style="list-style-type: none"> ■ Compressed air ■ Clean water supply ■ Mild detergent ■ Clean, dry cloths <p>NOTICE: Do not use a pressure washer to clean this machine. Pressurized water can severely damage the generator and sensitive electronic components.</p>
Cleaning the interior	<p>Clean the interior of the machine.</p> <ul style="list-style-type: none"> <input type="checkbox"/> Check the fluid level in the containment system (if equipped) and drain if necessary. See topic <i>Checking and Draining the Containment System</i>. <input type="checkbox"/> Remove rags, containers, or other debris from the cabinet. Nothing should be stored inside the machine. <input type="checkbox"/> Remove leaves and twigs from the exhaust compartment. <input type="checkbox"/> Wipe interior surfaces clean of oil, dust, and dirt.
Cleaning the exterior	Clean the exterior of the machine with clean water and a mild detergent.

16.5 Inspecting the Machine

When Daily

Overview Inspect the machine before each use. A thorough inspection will help to identify mechanical faults or potentially unsafe operating conditions. Correct these problems before operating the machine.

External inspection Perform an external inspection of the machine. Check for:

- External damage (dents, cracks, broken door latches, etc.)
- Loose or missing fasteners
- Loose or missing parts
- Fluid leaks
- Restricted air flow in the exhaust compartment
- Problems with the trailer—refer to topic *Maintaining the Trailer*

Internal inspection Open the access doors on both sides of the machine. Check for:

- Damage to control panel, switches, or customer connections
- Loose or missing fasteners
- Loose or missing parts
- Loose or damaged hoses
- Fluid leaks
- Rags, containers, or other debris inside the cabinet

16.6 Maintaining the Trailer

Tires

- Keep tires inflated to the proper pressure as shown on the tire sidewall.
- Check tread periodically for wear.
- Replace tires as required.

Wheels

- Check that lug nuts holding wheels are tight.
- Replace any missing lug nuts immediately.

Axle Hubs

- Grease axle hubs using a good wheel-bearing grease.

Brakes

- Check operation of brakes before each trip.
- Check level of brake fluid in actuator at front of trailer at regular intervals.
- Fill brake fluid to approximately 1 inch below top of reservoir using DOT-3 heavy-duty brake fluid.
- Tighten filler plug securely.

Note: *If fluid level has fallen too low, bleed brake lines to remove any air trapped in lines. Then fill to proper level with clean brake fluid.*

16.7 Checking and Draining the Containment System (if equipped)

When Check and drain the containment system every 50 hours.

Overview Certain machines are equipped with a containment system. The containment system protects the environment by collecting fluid leaks (fuel, coolant, or oil) which might otherwise contaminate the soil.

NOTICE: It is important to check the containment system regularly. A large amount of fluid collected in a 24-hour period indicates a significant leak.

- Requirements**
- Machine stopped and engine is cool to the touch
 - Machine is on a level surface
 - Plastic cloth and a container of sufficient volume to collect drained fluid
- Note:** *Collect, store, and dispose of drained fluid in accordance with current environmental protection regulations.*

- Procedure** Perform the procedure below to check and drain the containment system.
1. Open the access door on the side of the machine.
 2. Check the fluid level in the containment system.
 3. If fluid has accumulated, drain the containment system.
 - a. Place a plastic cloth and a collection container beneath the machine.
 - b. Remove the drain plug (a). Drain accumulated fluid into a suitable container.

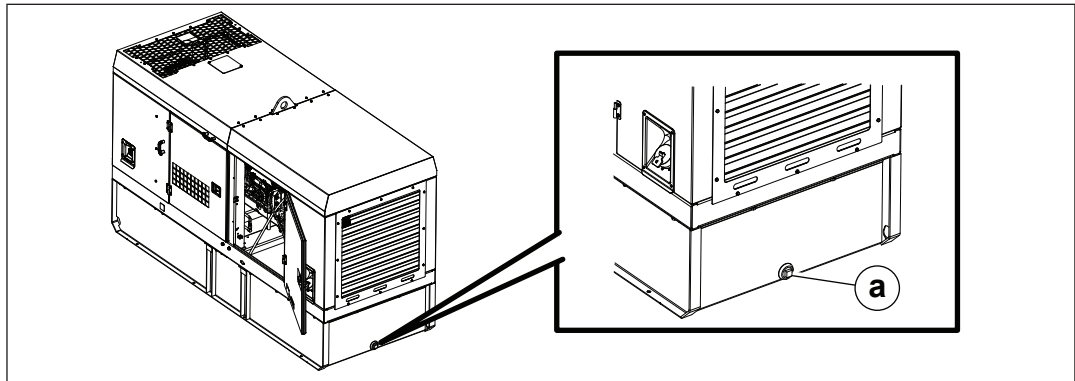

wc_gr012332

- c. Apply pipe sealant to the drain plug.
- d. Reinstall the drain plug.

16.8 Checking the Exhaust System

When Check the exhaust system weekly before operating the machine.

Background A leaky exhaust system will adversely affect machine operation. Symptoms include increased noise and visible soot deposits. Leaking exhaust can also ignite surrounding materials and pipe insulation, causing a fire.

Requirements

- Engine is stopped
- Exhaust pipes and muffler are cool to the touch

Procedure Perform the following procedure to check the exhaust system.

1. Open the access door on the curb side of the machine.

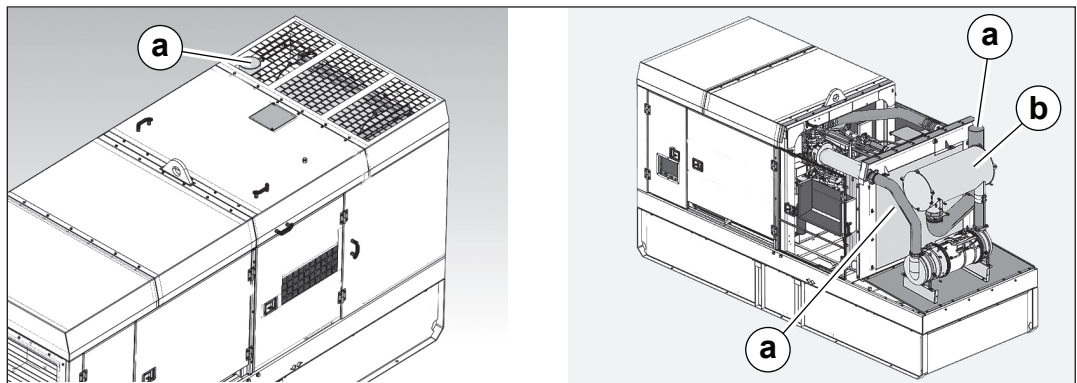

wc_gr009917

2. Inspect the exhaust pipes **(a)** and muffler **(b)**, looking for:

- Cracks or holes
- Burned or missing insulation
- Loose or missing clamps
- Black soot deposits, especially around welds and joints

3. Start the engine. Listen carefully for:

- Excessive noise
- Rumbling
- High-pitched whine
- Rattling

Repair or replace faulty components before putting the machine back into service.

16.9 Maintaining the Battery

**WARNING**

Explosion hazard. Batteries can emit explosive hydrogen gas.

- ▶ Keep all sparks and flames away from the battery.
- ▶ Do not short-circuit battery posts.

Safety precautions

Observe the following safety precautions to prevent serious damage to the electrical system.

- Do not disconnect the battery while the machine is running.
- Do not attempt to run the machine without a battery.
- Do not attempt to jump-start the machine.
- In the event that the machine has a discharged battery, either replace the battery with a fully charged battery or charge the battery using an appropriate battery charger.
- Dispose of waste batteries in accordance with local environmental regulations.

Battery connections

To connect the battery:

1. Place all electrical switches in the OFF position.
2. Connect the red positive (+) battery cable to the battery.
3. Connect the black negative (-) battery cable to the battery.

To disconnect the battery:

1. Stop the engine.
2. Place all electrical switches in the OFF position.
3. Disconnect the black negative (-) battery cable from the battery.
4. Disconnect the red positive (+) battery cable from the battery.

Maintaining battery condition

- Follow the battery manufacturer's maintenance recommendations.
- Keep battery terminals clean and connections tight.
- When necessary, tighten the cables and grease the cable clamps with petroleum jelly.
- Maintain the battery at full charge to improve cold weather starting.

16.10 Cleaning the Diesel Particulate Filter (DPF) (if equipped)

Overview

Sustained operation of the generator under load heats the DPF to a temperature high enough to burn accumulated soot. This cleaning process (passive regeneration) normally occurs automatically.

Soot may fill the DPF (a) when the engine runs at idle for long periods with no load. An indicator (b) on the control panel illuminates when the DPF is full of soot. The operator must then either increase the load on the engine, or perform a manual regeneration to clean the DPF.

Note: Graphic is representative only. Your machine may vary.

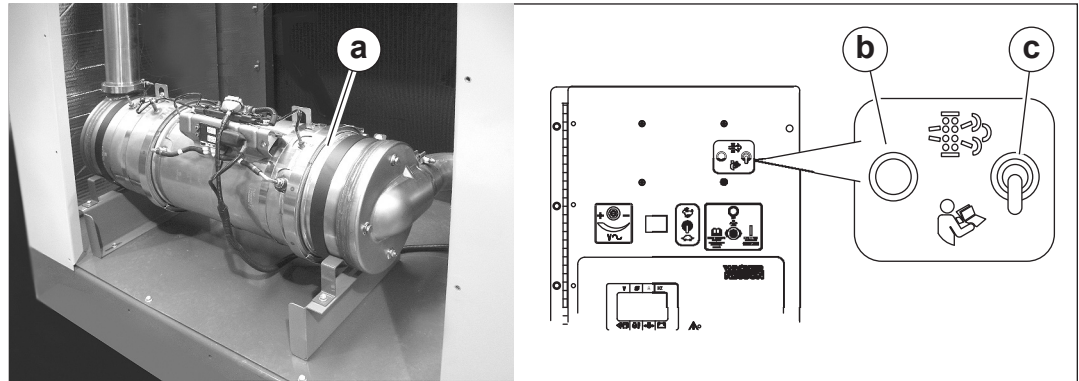

wc_gr009226



WARNING

Burn hazard. The engine, DPF, and exhaust pipe become very hot during operation.

- ▶ Do not touch the engine, DPF, or exhaust pipe while the machine is operating. Wait for these components to cool before touching them.

Manual regeneration

If the DPF indicator illuminates, follow the steps below to perform an manual regeneration.

1. Start the engine at low idle speed.
2. Set the manual regeneration switch (c) to the “on” position and hold it for five seconds. The DPF indicator will go out and the regeneration process will begin.
3. Release the switch.

The engine speed will gradually increase to about 1000 rpm while the machine is in regeneration mode. When regeneration is complete, the engine speed will return to low idle (about 750 rpm).

Note: The regeneration process may continue for up to one hour depending on ambient conditions and the amount of soot inside the DPF.

NOTICE: The DPF may be permanently damaged if the machine continues to operate with accumulated soot inside the DPF. Perform a manual regeneration as soon as possible after the indicator illuminates.

16.11 Filling the Radiator

When Every 2000 hours or 2 years

Requirements

- Machine shut down
- Engine cool to touch
- Fresh coolant (as needed)

Procedure Perform the procedure below to fill the radiator.



WARNING

Burn hazard. Engine coolant is hot and under pressure at operating temperature.

► Check the coolant level only after the engine has been shut down and is cool.

1. Open the access cover on the roof (a).

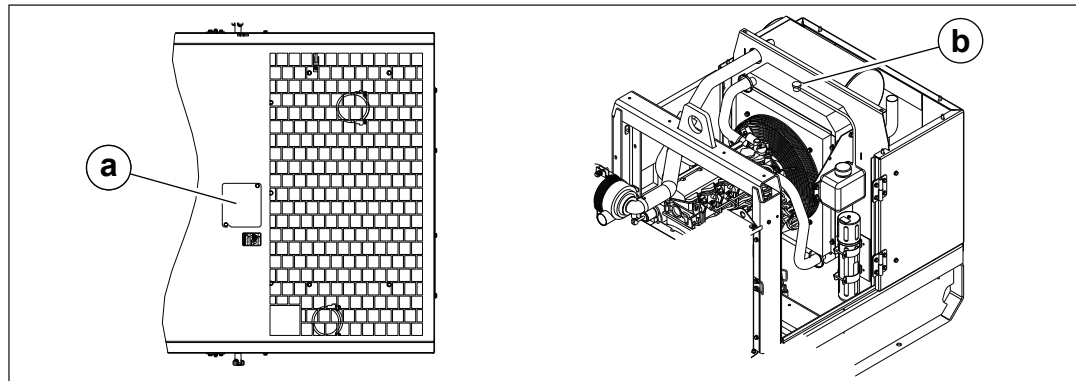

wc_gr012631



WARNING

Burn hazard. Coolant can contain alkali.

► Avoid coolant contact with skin and eyes.

2. Slowly rotate the radiator cap (b) counterclockwise to release any remaining system pressure. Unscrew and remove the radiator cap after the pressure has been release.
3. Add coolant by filling at a rate of approximately 1.5 gallons per minute for 6 minutes.
4. Wait 10 minutes. Then, fill at a rate of approximately 1.5 gallons per minute for 3.5 minutes or until full.
5. Run the machine under a 50% load for approximately 15 minutes until the coolant temperature exceeds 190°F.

This procedure continues on the next page.

Continued from the previous page.

6. Inspect the radiator cap and cap seal for damage. Clean the radiator cap or replace if necessary.
7. Reinstall the radiator cap.

NOTICE: Solutions of antifreeze and supplemental coolant additives **MUST** be used year-round. Automotive-type coolants do not contain the correct coolant additives to protect heavy-duty diesel engines. They often contain a high concentration of silicates which can damage the engine and cooling system.

Important

Use a long-life ethylene glycol coolant in this engine. Refer to the engine owner's manual for more information.

16.12 Replacing the Aftertreatment DEF Dosing Unit Filter (if equipped)

When Replace the aftertreatment Diesel Exhaust Fluid (DEF) dosing unit filter every 4500 hours or 3 years.

Requirements

- Machine stopped
- Replacement filter element
- Strap wrench or filter wrench
- Warm water
- Clean cloth
- Container of suitable size to collect residual DEF in filter housing



WARNING

Personal injury hazard. DEF contains urea. Do not get the substance in your eyes.

- ▶ In case of contact, immediately flush eyes with large amounts of water for a minimum of 15 minutes.



WARNING

The DEF line connecting the aftertreatment DEF dosing unit to the aftertreatment DEF dosing valve is under low pressure and should not be disconnected while the engine is running or before the system has completed the purge process after engine shutdown. Disconnecting the DEF line while under low pressure could cause DEF to spray.

- ▶ Do not disconnect the DEF line while under low pressure.

Procedure Perform the procedure below to replace the aftertreatment DEF dosing unit filter.

Note: *In the interests of the environment protection, place a container under the filter cap to collect the residual DEF liquid that may be in the filter housing. Dispose of the DEF in accordance with the environment protection legislation.*

1. Remove the filter cap (a).
2. Remove the filter equalizing element (b).
3. Use the disposable filter tool (c) to aid in removing the filter element (d). Use the appropriate end of the tool, depending on the color of the plastic on the filter.

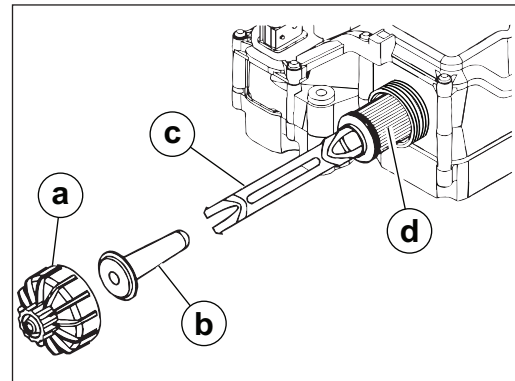

wc_gr012300

Note: *The disposable filter tool will make a “click” sound. This indicates that the filter element is properly engaged.*

4. Clean the filter cap and threads with warm water and a clean cloth.

Note: *Inspect the filter cap for cracks or leaks. If the threads are damaged, replace the filter cap.*

- Installation**
1. Insert the equalizing element into the new filter.
 2. Insert the filter assembly into the aftertreatment dosing unit.
 3. Reinstall the filter cap and torque it to 20 Nm (14.8 ft.lbs.).

16.13 Storage

Extended storage of equipment requires preventive maintenance. Performing these steps helps to preserve machine components and ensures the machine will be ready for future use. While not all of these steps necessarily apply to this machine, the basic procedures remain the same.

When Prepare your machine for extended storage if it will not be operated for 30 days or more.

- Preparing for storage** Perform the procedures below to prepare your machine for storage.
- Complete any needed repairs.
 - Replenish or change oils (engine, exciter, hydraulic, and gearcase) per the intervals specified in the Scheduled Maintenance table.
 - Grease all fittings and, if applicable, repack bearings.
 - Inspect engine coolant. Replace coolant if it appears cloudy, is more than two seasons old, or does not meet the average lowest temperature for your area.
 - If your machine has an engine equipped with a fuel valve, start the engine, close the fuel valve, and run the engine until it stops.
 - Consult the engine owner’s manual for instructions on preparing the engine for storage.

Stabilizing the fuel After completing the procedures listed above, fill the fuel tank completely and add a high-quality stabilizer to the fuel.

- Choose a stabilizer that includes cleaning agents and additives designed to coat/protect the cylinder walls.
 - Make sure the stabilizer you use is compatible with the fuel in your area, fuel type, grade, and temperature range. Do not add extra alcohol to fuels which already contain it (for example, E10).
 - For engines with diesel fuel, use a stabilizer with a biocide to restrict or prevent bacteria and fungus growth.
 - Add the correct amount of stabilizer per the manufacturer's recommendations.
-

Storing the machine

Perform these remaining steps to store your machine.

- Wash the machine and allow it to dry.
- Move the machine to a clean, dry, secure storage location. Block or chock the wheels to prevent machine movement.
- Use touch-up paint as needed to protect exposed metal against rust.
- If the machine has a battery, either remove or disconnect it.

NOTICE: Allowing the battery to freeze or completely discharge is likely to cause permanent damage. Periodically charge the battery while the machine is not in use. In cold climates, store and charge the battery indoors or in a warm location.

- Cover the machine. Exposed rubber items should be protected from the weather. Either cover them or use a protectant.

16.14 Machine Disposal and Decommissioning

Introduction This machine must be properly decommissioned at the end of its service life. Responsible disposal of recyclable components, such as plastic and metal, ensures that these materials can be reused—conserving landfill space and valuable natural resources.

Responsible disposal also prevents toxic chemicals and materials from harming the environment. The operating fluids in this machine, including fuel, engine oil, and grease, may be considered hazardous waste in many areas. Before decommissioning this machine, read and follow local safety and environmental regulations pertaining to the disposal of construction equipment.

Preparation Perform the following tasks to prepare the machine for disposal.

- Move the machine to a protected location where it will not pose any safety hazards and cannot be accessed by unauthorized individuals.
 - Ensure that the machine cannot be operated from the time of final shutdown to disposal.
 - Drain all fluids, including fuel, engine oil, and coolant.
 - Seal any fluid leaks.
-

Disposal

Perform the following tasks to dispose of the machine.

- Disassemble the machine and separate all parts by material type.
- Dispose of recyclable parts as specified by local regulations.
- Dispose of all non-hazardous components that cannot be recycled.
- Dispose of waste fuel, oil, and grease in accordance with local environmental protection regulations.

17 Maintenance Tier 4i Engines: Isuzu

The viscosity of the engine oil is an important factor when determining the correct engine oil to use in your machine. Use an engine oil of appropriate viscosity based on the expected outside air temperature. See the following table.



WARNING

Most used liquids from this machine such as oil, gasoline, grease, etc., contain small amounts of materials that can cause cancer and other health problems if inhaled, ingested, or left in contact with skin for prolonged periods of time.

- ▶ Take steps to avoid inhaling or ingesting used liquids.
- ▶ Wash skin thoroughly after exposure to used liquids.

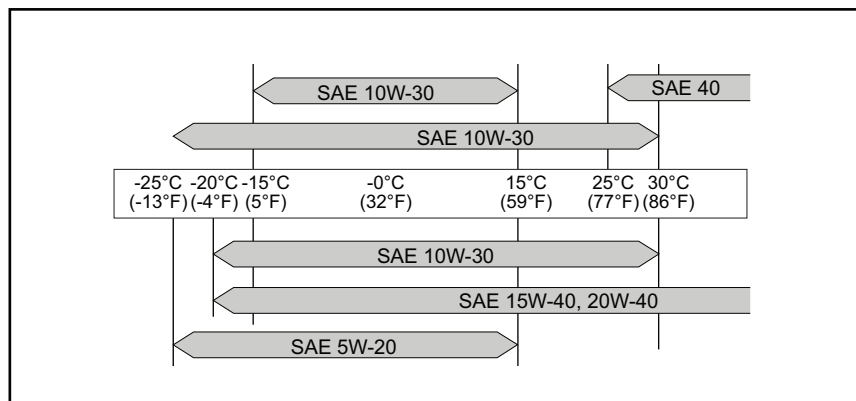

wc_gr011765

The engine maintenance schedule(s) in this chapter are reproduced from the engine owner's manual. For additional information, see the engine owner's manual.

ENGINE MAINTENANCE SCHEDULE

When performing the following items, the daily inspection items should also be carried out.

NO.	Description of check and maintenance	Daily	(operation hours)						Remark
			250	500	750	1000	1250	1500	
1.	Oil level and oil fouling	○							
2.	Oil leakage check	○							
3.	Oil pressure gauge registration	○							
4.	Oil pressure warning lamp	○							
5.	Engine oil replacement (Cartridge type)		○	○	○	○	○	○	○
6.	Engine oil replacement (Remote filter type)			○		○		○	
7.	Oil filter element replacement			○		○		○	
8.	Fuel leakage check	○							
9.	Draining water in fuel filter	○							
	w/water sediment								
10.	Fuel filter element replacement		○★	○	○★	○	○	○★	○
11.	Water sediment element cleaning		○★	○	○★	○	○	○★	○

★ This is a recommended maintenance. The failure to perform this maintenance item will nullify the emission warranty or limit recall liability prior to the completion engine useful life. Isuzu, however, urges that recommended maintenance service is performed at the indicated intervals.

770011

NO.	Description of check and maintenance	Daily	(operation hours)						Remark	
			250	500	750	1000	1250	1500		
12.	Electromagnetic pump filter replacement or cleaning		○★	○	○★	○	○	○★	○	
13.	Injection nozzle check (*)			○★			○★		○◎	
14.	Coolant level and fouling check	○								
15.	Coolant leakage check	○								
16.	Radiator filler cap fitting condition	○								
17.	Fan belt tension check (Replace if necessary.)	○		○			○		○	
18.	Coolant temperature registration	○								
19.	Coolant replacement									
20.	Intercooler and radiator external face cleaning									
21.	Cooling system circuit cleaning						○			
22.	Radiator filler cap function check (*)									

★ This is a recommended maintenance. The failure to perform this maintenance item will nullify the emission warranty or limit recall liability prior to the completion engine useful life. Isuzu, however, urges that recommended maintenance service is performed at the indicated intervals.

◎ This is a required maintenance. The failure to perform this maintenance item will nullify the emission warranty or limit recall liability prior to the completion engine useful life. Isuzu, however, urges that required maintenance service is performed at the indicated intervals.

770012

17.1 Coolant

Always refer to the chart to determine the correct cooling water to antifreeze solution mixing ratio.

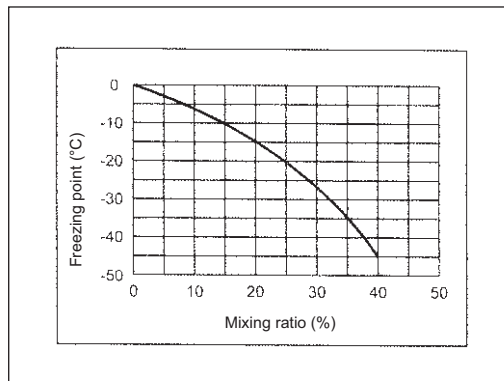

wc_gr015017

NOTICE

1. Supplement inhibitors or additives claiming to provide increased cooling capability that have not been specifically approved by Isuzu are not recommended for addition to the cooling system.
2. When supplying or replacing coolant, do not use water of well or river, but be sure to use tap water (soft water), distilled water or demineralized water.
3. It is strongly recommended to use Isuzu genuine engine coolant or equivalent for addition or replacement.
4. Coolants from other brands often do not contain anti-corrosive, and use of such products could result in corrosion of the engine and radiator.
5. If the density of Isuzu genuine engine coolant exceeds 60%, the reduced specific heat characteristic of the coolant could result in overheating. If the density is below 20%, the anti-corrosion characteristic may degrade. Adjust the coolant density in the range from 20% to 60% according to the situation.

When the atmospheric temperature falls below freezing point, the cooling system should be drained after engine operation, but to eliminate the need for repeated draining and refilling, the use of antifreeze solution is highly recommended.

A 50/50 mix ethylene glycol base antifreeze/tap water (soft water), distilled water or demineralized water (which provides protection to -37°C (-34°F)) is recommended for use in these ISUZU diesel engines.

Concentrations over 65% adversely affect freeze protection, heat transfer rates, and silicate stability which may cause water pump leakage.

Never exceed a 60/40 mix antifreeze/tap water (soft water), distilled water or demineralized water (which provides protection to about -50°C (-58°F)).



CAUTION

Under some conditions the ethylene glycol in the engine coolant is combustible. To help avoid being burned when adding engine coolant, do not spill it on the exhaust system or engine parts that may be hot. If there is any question, have this service performed by a qualified technician.

18 Maintenance Tier 4f Engines: Isuzu

The viscosity of the engine oil is an important factor when determining the correct engine oil to use in your machine. Use an engine oil of appropriate viscosity based on the expected outside air temperature. See the following table.



WARNING

Most used liquids from this machine such as oil, gasoline, grease, etc., contain small amounts of materials that can cause cancer and other health problems if inhaled, ingested, or left in contact with skin for prolonged periods of time.

- ▶ Take steps to avoid inhaling or ingesting used liquids.
- ▶ Wash skin thoroughly after exposure to used liquids.

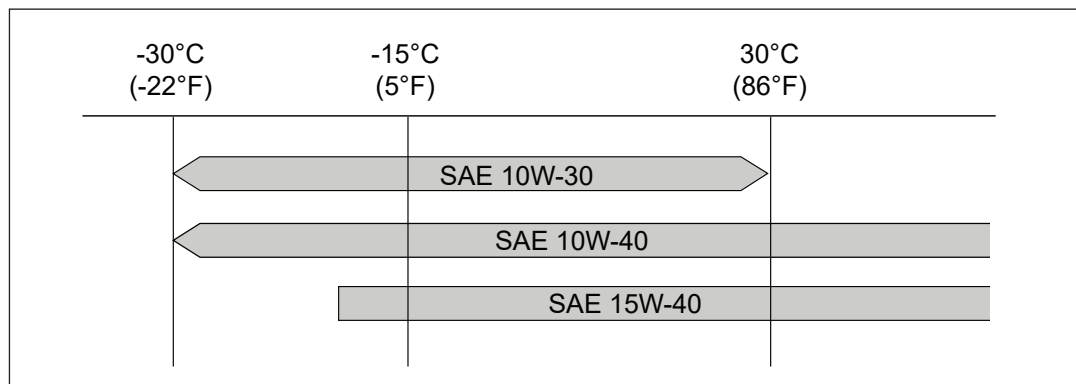

wc_gr011764

The engine maintenance schedule(s) in this chapter are reproduced from the engine owner’s manual. For additional information, see the engine owner’s manual.

Periodic Inspection and Maintenance List

In order to maintain safe and economical engine operation, performance of periodic inspection and maintenance is recommended.



ADVICE

- After 1500 hours, perform inspection and maintenance for every 250 hours or 500 hours in accordance with this table.

Lubrication System

Inspection/Maintenance Item	Daily	250 hours	500 hours	750 hours	1000 hours	1250 hours	1500 hours	Remarks
Oil level and contamination	●							
Oil leak	●							
Oil pressure gauge indication or lighting of warning light	●							Approx. 285 kPa (3 kgf/cm ² /43 psi) or more per 2200 min ⁻¹
Oil pressure warning light	●							Off (in operation)
Replacing the engine oil (Remote filter type)			●		●		●	Every 500 hours
Replacing the engine oil (Cartridge type)		●	●	●	●	●	●	Every 250 hours
Replacing the oil filter			●		●		●	Every 500 hours

770001

Fuel System

Inspection/Maintenance Item	Daily	250 hours	500 hours	750 hours	1000 hours	1250 hours	1500 hours	Remarks
Fuel leak	●							
Water removal from fuel	●							
Replacing the fuel filter element			●*1		●*1		●*1	Every 500 hours
Inspecting and cleaning the supply pump strainer			●		●		●	Every 500 hours
Replacing the electromagnetic pump filter (paper type)			●*1		●*1		●*1	Every 500 hours
Cleaning the electromagnetic pump filter (steel mesh type)			●*1		●*1		●*1	Every 500 hours
Inspecting and cleaning the injector								Every 3000 hours

*1: Shorten the interval from every 500 hours to every 250 hours depending on the fuel management and refuel status.

770006

Cooling System

Inspection/Maintenance Item	Daily	250 hours	500 hours	750 hours	1000 hours	1250 hours	1500 hours	Remarks
Coolant quantity	●							Inspecting the reserve tank
Abnormal discoloration and contamination of coolant	●							
Coolant leak	●							
Radiator cap installation condition	●							As specified by the machine manufacturer
Inspecting (replacing) the generator drive belt	●		●		●		●	Deflection when approx. 98 N (10 kgf/22 lb) is applied •Single belt -When reused: 6.0 - 6.5 mm (0.24 - 0.26 in) -New belt: 5.5 - 6.0 mm (0.22 - 0.24 in) •Double belt -When reused: 8.3 - 9.3 mm (0.33 - 0.37 in) -New belt: 7.7 - 8.7 mm (0.30 - 0.34 in)
Inspection using the coolant temperature gauge or monitor	●							75 - 90°C (167 - 194°F)
Replacing the coolant								Every 12 months
Cleaning the coolant passage								Every 12 months
Cleaning the intercooler and radiator exterior	●							As specified by the machine manufacturer
Inspection and maintenance the cooling system	●							As specified by the machine manufacturer
Inspecting the functionality of radiator cap*	●							As specified by the machine manufacturer

* : When performing inspection or maintenance, consult an Isuzu Distributor. 770007

Intake/Exhaust System

Inspection/Maintenance Item	Daily	250 hours	500 hours	750 hours	1000 hours	1250 hours	1500 hours	Remarks
Replacing the air cleaner element								As specified by the machine manufacturer
Inspecting the air filter case for cracking and replacing it as necessary							●	Every 1500 hours
Inspecting the turbocharger								Every 3000 hours (blower cleaning as necessary)
Inspecting and cleaning the EGR valve								Every 3000 hours
Inspecting and cleaning the EGR cooler							●	Every 1500 hours

* : When performing inspection or maintenance, consult an Isuzu Distributor. 770008

Electrical System

Inspection/Maintenance Item	Daily	250 hours	500 hours	750 hours	1000 hours	1250 hours	1500 hours	Remarks
Inspecting the engine failure indication and liquid crystal display (LCD)	●							
Inspecting the battery fluid level	●							Adding distilled water (As specified by the machine manufacturer)
Cleaning the battery terminals	●							
Charging status	Current meter	●						Immediately after start, + side (large) → (small) Normal operation, + side (small)
	Charge light	●						Off (in operation)
Measuring the specific gravity of battery fluid	●							As specified by the machine manufacturer
Inspecting and cleaning the starter and generator*					●			Every 1000 hours
Inspecting the wiring and connections								As specified by the machine manufacturer
Preheating status	●							
Inspection the engine controller (ECM)								Every 3000 hours

* : When performing inspection or maintenance, consult an Isuzu Distributor. 770009

Engine/Others

Inspection/Maintenance Item	Daily	250 hours	500 hours	750 hours	1000 hours	1250 hours	1500 hours	Remarks
Inspecting and replacing the fuel oil pipe and coolant pipe								Every 24 months
Engine startability and abnormal noises	●							
Exhaust conditions	●							Exhaust color
Measuring the compression pressure*					●			Every 1000 hours
Inspecting and adjusting the valve clearance*					●			Every 1000 hours 0.40 mm (0.016 in) for both intake and exhaust (in cold engine)

* : When performing inspection or maintenance, consult an Isuzu Distributor. 770010

18.1 Coolant

The coolant is a type of fluid which is made by mixing tap water and the long-life coolant “BESCO LLC SUPER TYPE E or BESCO LLC SUPER TYPE AS” with an appropriate ratio. It has the function of cooling off the heat generated by the engine.

Handling the long-life coolant

To prevent the engine damage due to freezing of the coolant and to protect the cooling system from corrosion, mix the Isuzu specified long-life coolant (LLC) and tap water with an appropriate ratio.

Usage region	Outside temperature	Long-life coolant concentration
Warm region (other than the cold region specifications)	-12°C (10°F) or above	30%
Cold region (cold region specifications)	-30°C (22°F) or above	50%

19 Troubleshooting

Problem	Cause	Remedy
Engine does not start	Battery discharged Battery connections corroded Blown fuse Defective starter	Charge battery. Clean battery connections. Replace fuse. Replace starter.
Engine tries to start but stops	No fuel Clogged fuel filter Fuel circuit failure Lug door open at engine start (Deep Sea only)	Fill tank with fuel. Bleed fuel lines. Replace fuel filter. Check fuel lines. Close lug doors before starting the engine.
No generator output	Main circuit breaker open Lug door open	Close main circuit breaker. Close lug door.
Low oil pressure	Low oil level Clogged oil filter	Fill engine sump with oil. Replace oil filter.
High coolant temperature	Overload Low coolant level Low oil level Clogged oil filter	Reduce load. Fill with coolant. Fill sump with oil. Replace oil filter.
Engine emits black smoke	Clogged air filter Overload High oil level	Clean/replace air filter cartridges. Reduce load. Remove excess oil.

20 Technical Data

20.1 Engine

Engine Power Rating

Net standby power rating per ISO 8528-1 and SAE J1349. Actual power output may vary due to conditions of specific use.

		G 25	G 25 ERT
Engine			
Engine make / type		Isuzu	
Model		4LE2-NYGV, Tier 4 Interim	
Number of cylinders		4	
Displacement	cm ³ (in. ³)	2179 (133)	
Engine speed	rpm	1800	
Power @ 1800 rpm - continuous/ standby	kW (hp)	22.9 (30.7) / 25.6 (34.3)	
Coolant capacity	L (qt)	11.3 (11.9)	
Oil capacity	L (qt)	8.0 (8.5)	
Battery	volts/ccA	12/750—0620640, 0620931, 0620709 12/950—0620641, 0620642	
Fuel type		Diesel ²	
Fuel tank capacity	L (gal)	221 (58.4)	490 (129.4)
Fuel consumption, prime load	L (gal)/hr	6.8 (1.8)	
Run time at 100% prime load ¹	hours	28.2	67.6

¹ Run times are based on useable fuel volume, not on fuel tank capacity. "Useable fuel volume" does not include fuel remaining in the tank after a low fuel shutdown.

See "Refueling the Machine" for more information.

² The use of #6 diesel fuel is not recommended.

		G 25	G 25 ERT
Engine			
Engine make / type		Isuzu	
Model		4LE2-TAGV, Tier 4 Final	
Number of cylinders		4	
Displacement	cm ³ (in. ³)	2179 (133)	
Engine speed	rpm	1800	
Power @ 1800 rpm - continuous/ standby	kW (hp)	23.5 (31.5) / 30.0 (40.0)	
Coolant capacity	L (qt)	12.6 (13.3)	
Oil capacity	L (qt)	10.4 (11)	
Battery	volts/ccA	12/750—520009370, 520009373, 520009376, 520009377 12/950—520009371, 520009372, 520009374, 520009375	
Fuel type		Diesel ²	
Fuel tank capacity	L (gal)	221 (58.4)	490 (129.4)
Fuel consumption, prime load	L (gal)/hr	6.8 (1.8)	
Run time at 100% prime load ¹	hours	28.2	67.6

¹ Run times are based on useable fuel volume, not on fuel tank capacity. "Useable fuel volume" does not include fuel remaining in the tank after a low fuel shutdown.

See "Refueling the Machine" for more information.

² The use of #6 diesel fuel is not recommended.

20.2 Generator

Machine		G 25 G 25 ERT
Generator		
Make/Type		Mecc Alte / Brushless
Model		ECO 28-2LN/4
Generator speed	rpm	1800
Voltage selector switch		3 position
AC voltages available		120/240 VAC 1Ø
		208/240 VAC 3Ø 120/139 VAC 1Ø
		277/480 VAC 3Ø
Frequency		60 Hz
Power factor	1Ø 3Ø	1.0 0.8
Voltage regulation		±1.00%
Insulation class		H
Sound level at 7 m (23 ft)	db(A)	65
AC receptacles 1Ø 120V GFI duplex 1Ø 120V/240V twist lock	Qty/A Qty/A	2 duplex, 2 twist-lock 2/20A 2/50A (1-20A optional) (1-30A optional)
Standby output	kW/kVA	20.4/25.5
Continuous output	kW/kVA	19.5/24.4

Machine		G 25 600 Volt
Generator		
Make/Type		Mecc Alte / Brushless
Model		ECO 28-2L/4
Generator speed	rpm	1800
Voltage selector switch		4 position
AC voltages available		120/240 VAC 1Ø
		208/240 VAC 3Ø 120/139 VAC 1Ø
		277/480 VAC 3Ø
		346/600 VAC 3Ø
Frequency		60 Hz
Power factor	1Ø 3Ø	1.0 0.8
Voltage regulation		±1.00%
Insulation class		H
Sound level at 7 m (23 ft)	db(A)	65
AC receptacles 1Ø 120V GFI duplex 1Ø 120V/240V twist lock	Qty/A Qty/A	2 duplex, 2 twist-lock 2/20A 2/50A (1-20A optional) (1-30A optional)
Standby output	kW/kVA	19.5/24.4
Continuous output	kW/kVA	18.7/23.4

20.3 Trailer and Skid

With Tier 4i Isuzu engine

Machine		G 25	G 25 ERT
Trailer and Skid			
Dry weight of skid	kg (lb)	867 (1911)	950 (2094)
Operating weight of skid	kg (lb)	1,058 (2333)	1,372 (3026)
Trailer weight	kg (lb)	182 (400)	290 (640)
GVWR	kg (lb)	1,338 (2,995)	
Surge brakes	fluid type	DOT3	
Tires	size	ST205/75D-15C	

With Tier 4f Isuzu engine

Machine		G 25	G 25 ERT
Trailer and Skid			
Dry weight of skid	kg (lb)	885 (1,952)	969 (2,136)
Operating weight of skid	kg (lb)	1,076 (2,373)	1,391 (3,068)
Trailer weight	kg (lb)	182 (400)	290 (640)
GVWR	kg (lb)	1,338 (2,995)	
Surge brakes	fluid type	DOT3	
Tires	size	ST205/75D-15C	

20.4 Dimensions

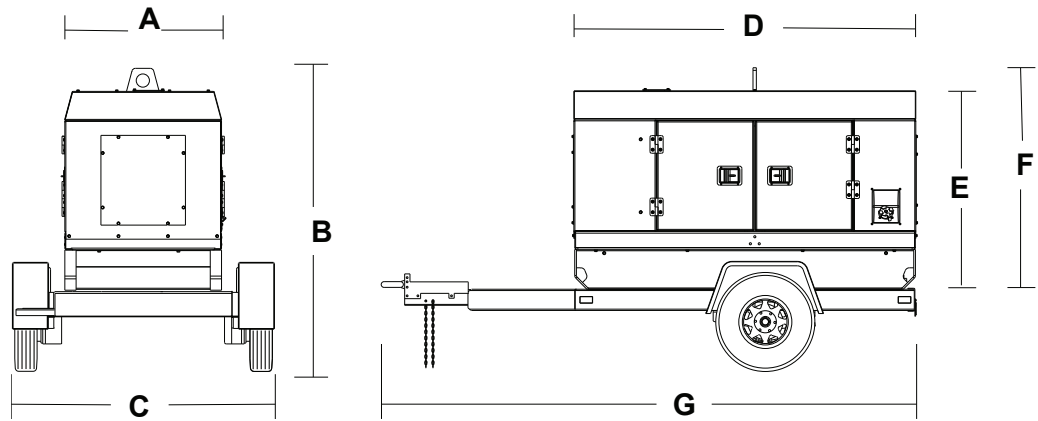

wc_gr001680

Ref.		G 25	G 25 ERT
Dimensions			
A	mm (in.)	890 (35)	
B		1620 (69)	2032 (80)
C		1700 (67)	
D		1945 (76.6)	
E		1130 (44.5)	1384 (54.5)
F		1260 (49.6)	1514 (59.6)
G		3922 (154.4)	

Tire Safety Information

21 Tire Safety Information

Introduction to Tire Safety Information

Federal Regulation 49 CFR 575 requires trailer manufacturers to include certain tire information in the owner's manuals for the trailers they manufacture. This regulation requires that the information be in the English language. This chapter includes all the information required by Federal Regulation 49 CFR 575.

1. TIRE SAFETY INFORMATION

This portion of the User's Manual contains tire safety information as required by 49 CFR 575.6.

Section 1.1 contains "Steps for Determining Correct Load Limit - Trailer".

Section 1.2 contains "Steps for Determining Correct Load Limit – Tow Vehicle".

Section 1.3 contains a Glossary of Tire Terminology, including "cold inflation pressure", "maximum inflation pressure", "recommended inflation pressure", and other non-technical terms.

Section 1.4 contains information from the NHTSA brochure entitled "Tire Safety – Everything Rides On It". This brochure, as well as the preceding subsections, describes the following items;

- Tire labeling, including a description and explanation of each marking on the tires, and information about the DOT Tire Identification Number (TIN).
- Recommended tire inflation pressure, including a description and explanation of:
 - A. Cold inflation pressure.
 - B. Vehicle Placard and location on the vehicle.
 - C. Adverse safety consequences of under inflation (including tire failure).
 - D. Measuring and adjusting air pressure for proper inflation.
- Tire Care, including maintenance and safety practices.
- Vehicle load limits, including a description and explanation of the following items:
 - A. Locating and understanding the load limit information, total load capacity, and cargo capacity.
 - B. Calculating total and cargo capacities with varying seating configurations including quantitative examples showing / illustrating how the vehicles cargo and luggage capacity decreases as combined number and size of occupants' increases. This item is also discussed in Section 3.
 - C. Determining compatibility of tire and vehicle load capabilities.
 - D. Adverse safety consequences of overloading on handling and stopping on tires.

1.1. STEPS FOR DETERMINING CORRECT LOAD LIMIT – TRAILER

Determining the load limits of a trailer includes more than understanding the load limits of the tires alone. On all trailers there is a Federal certification/VIN label that is located on the forward half of the left (road) side of the unit. This certification/VIN label will indicate the trailer's Gross Vehicle Weight Rating (GVWR). This is the most weight the fully loaded trailer can weigh. It will also provide the Gross Axle Weight Rating (GAWR). This is the most a particular axle can weigh. If there are multiple axles, the GAWR of each axle will be provided.

If your trailer has a GVWR of 10,000 pounds or less, there is a vehicle placard located in the same location as the certification label described above. This placard provides tire and loading information. In addition, this placard will show a statement regarding maximum cargo capacity. Cargo can be added to the trailer, up to the maximum weight specified on the placard. The combined weight of the cargo is provided as a single number. In any case, remember: the total weight of a fully loaded trailer can not exceed the stated GVWR.

For trailers with living quarters installed, the weight of water and propane also need to be considered. The weight of fully filled propane containers is considered part of the weight of the trailer before it is loaded with cargo, and is not considered part of the disposable cargo load. Water however, is a disposable cargo weight and is treated as such. If there is a fresh water storage tank of 100 gallons, this tank when filled would weigh about 800 pounds. If more cargo is being transported, water can be off-loaded to keep the total amount of cargo added to the vehicle within the limits of the GVWR so as not to overload the vehicle. Understanding this flexibility will allow you, the owner, to make choices that fit your travel needs.

When loading your cargo, be sure it is distributed evenly to prevent overloading front to back and side to side. Heavy items should be placed low and as close to the axle positions as reasonable. Too many items on one side may overload a tire. The best way to know the actual weight of the vehicle is to weigh it at a public scale. Talk to your dealer to discuss the weighing methods needed to capture the various weights related to the trailer. This would include the weight empty or unloaded, weights per axle, wheel, hitch or king-pin, and total weight.

Tire Safety Information

Excessive loads and/or underinflation cause tire overloading and, as a result, abnormal tire flexing occurs. This situation can generate an excessive amount of heat within the tire. Excessive heat may lead to tire failure. It is the air pressure that enables a tire to support the load, so proper inflation is critical. The proper air pressure may be found on the certification/VIN label and/or on the Tire Placard. This value should never exceed the maximum cold inflation pressure stamped on the tire.

1.1.1. TRAILERS 10,000 POUNDS GVWR OR LESS

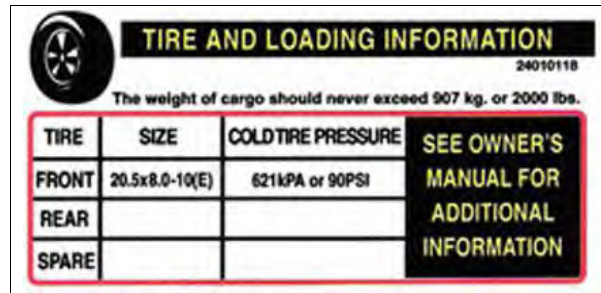

The image shows a 'TIRE AND LOADING INFORMATION' placard. At the top left is a tire icon. To its right, the title 'TIRE AND LOADING INFORMATION' is written in yellow on a black background, with the number '24010118' below it. Underneath the title, it states 'The weight of cargo should never exceed 907 kg. or 2000 lbs.' Below this is a table with four rows: 'TIRE', 'SIZE', 'COLD TIRE PRESSURE', and 'SEE OWNER'S MANUAL FOR ADDITIONAL INFORMATION'. The 'FRONT' row has '20.5x8.0-10(E)' for size and '621kPa or 90PSI' for pressure. The 'REAR' and 'SPARE' rows are empty. The table is enclosed in a red border.

TIRE	SIZE	COLD TIRE PRESSURE	SEE OWNER'S MANUAL FOR ADDITIONAL INFORMATION
FRONT	20.5x8.0-10(E)	621kPa or 90PSI	
REAR			
SPARE			

Tire and Loading Information Placard – Figure 1-1

1. Locate the statement, “The weight of cargo should never exceed XXX kg or XXX lbs.,” on your vehicle’s placard. See figure 1-1.
2. This figure equals the available amount of cargo and luggage load capacity.
3. Determine the combined weight of luggage and cargo being loaded on the vehicle. That weight may not safely exceed the available cargo and luggage load capacity.

The trailer’s placard refers to the Tire Information Placard attached adjacent to or near the trailer’s VIN (Certification) label at the left front of the trailer.

1.1.2. TRAILERS OVER 10,000 POUNDS GVWR (NOTE: THESE TRAILERS ARE NOT REQUIRED TO HAVE A TIRE INFORMATION PLACARD ON THE VEHICLE)

1. Determine the empty weight of your trailer by weighing the trailer using a public scale or other means. This step does not have to be repeated.
2. Locate the GVWR (Gross Vehicle Weight Rating) of the trailer on your trailer’s VIN (Certification) label.
3. Subtract the empty weight of your trailer from the GVWR stated on the VIN label. That weight is the maximum available cargo capacity of the trailer and may not be safely exceeded.

1.2. STEPS FOR DETERMINING CORRECT LOAD LIMIT – TOW VEHICLE

1. Locate the statement, “The combined weight of occupants and cargo should never exceed XXX lbs.,” on your vehicle’s placard.
2. Determine the combined weight of the driver and passengers who will be riding in your vehicle.
3. Subtract the combined weight of the driver and passengers from XXX kilograms or XXX pounds.
4. The resulting figure equals the available amount of cargo and luggage capacity. For example, if the “XXX” amount equals 1400 lbs. and there will be five 150 lb. passengers in your vehicle, the amount of available cargo and luggage capacity is 650 lbs. (1400-750 (5 x 150) = 650 lbs.).
5. Determine the combined weight of luggage and cargo being loaded on the vehicle. That weight may not safely exceed the available cargo and luggage capacity calculated in Step # 4.
6. If your vehicle will be towing a trailer, load from your trailer will be transferred to your vehicle. Consult the tow vehicle’s manual to determine how this weight transfer reduces the available cargo and luggage capacity of your vehicle.

1.3. GLOSSARY OF TIRE TERMINOLOGY

Accessory weight

The combined weight (in excess of those standard items which may be replaced) of automatic transmission, power steering, power brakes, power windows, power seats, radio and heater, to the extent that these items are available as factory-installed equipment (whether installed or not).

Bead

The part of the tire that is made of steel wires, wrapped or reinforced by ply cords and that is shaped to fit the rim.

Bead separation

This is the breakdown of the bond between components in the bead.

Bias ply tire

A pneumatic tire in which the ply cords that extend to the beads are laid at alternate angles substantially less than 90 degrees to the centerline of the tread.

Carcass

The tire structure, except tread and sidewall rubber which, when inflated, bears the load.

Chunking

The breaking away of pieces of the tread or sidewall.

Cold inflation pressure

The pressure in the tire before you drive.

Cord

The strands forming the plies in the tire.

Cord separation

The parting of cords from adjacent rubber compounds.

Cracking

Any parting within the tread, sidewall, or inner liner of the tire extending to cord material.

CT

A pneumatic tire with an inverted flange tire and rim system in which the rim is designed with rim flanges pointed radially inward and the tire is designed to fit on the underside of the rim in a manner that encloses the rim flanges inside the air cavity of the tire.

Curb weight

The weight of a motor vehicle with standard equipment including the maximum capacity of fuel, oil, and coolant, and, if so equipped, air conditioning and additional weight optional engine.

Extra load tire

A tire designed to operate at higher loads and at higher inflation pressures than the corresponding standard tire.

Groove

The space between two adjacent tread ribs.

Gross Axle Weight Rating

The maximum weight that any axle can support, as published on the Certification / VIN label on the front left side of the trailer. Actual weight determined by weighing each axle on a public scale, with the trailer attached to the towing vehicle.

Gross Vehicle Weight Rating

The maximum weight of the fully loaded trailer, as published on the Certification / VIN label. Actual weight determined by weighing trailer on a public scale, without being attached to the towing vehicle.

Hitch Weight

The downward force exerted on the hitch ball by the trailer coupler.

Innerliner

The layer(s) forming the inside surface of a tubeless tire that contains the inflating medium within the tire.

Innerliner separation

The parting of the innerliner from cord material in the carcass.

Tire Safety Information

Intended outboard sidewall

The sidewall that contains a white-wall, bears white lettering or bears manufacturer, brand, and/or model name molding that is higher or deeper than the same molding on the other sidewall of the tire or the outward facing sidewall of an asymmetrical tire that has a particular side that must always face outward when mounted on a vehicle.

Light truck (LT) tire

A tire designated by its manufacturer as primarily intended for use on lightweight trucks or multipurpose passenger vehicles.

Load rating

The maximum load that a tire is rated to carry for a given inflation pressure.

Maximum load rating

The load rating for a tire at the maximum permissible inflation pressure for that tire.

Maximum permissible inflation pressure

The maximum cold inflation pressure to which a tire may be inflated.

Maximum loaded vehicle weight

The sum of curb weight, accessory weight, vehicle capacity weight, and production options weight.

Measuring rim

The rim on which a tire is fitted for physical dimension requirements.

Pin Weight

The downward force applied to the 5th wheel or gooseneck ball, by the trailer kingpin or gooseneck coupler.

Non-pneumatic rim

A mechanical device which, when a non-pneumatic tire assembly incorporates a wheel, supports the tire, and attaches, either integrally or separably, to the wheel center member and upon which the tire is attached.

Non-pneumatic spare tire assembly

A non-pneumatic tire assembly intended for temporary use in place of one of the pneumatic tires and rims that are fitted to a passenger car in compliance with the requirements of this standard.

Non-pneumatic tire

A mechanical device which transmits, either directly or through a wheel or wheel center member, the vertical load and tractive forces from the roadway to the vehicle, generates the tractive forces that provide the directional control of the vehicle and does not rely on the containment of any gas or fluid for providing those functions.

Non-pneumatic tire assembly

A non-pneumatic tire, alone or in combination with a wheel or wheel center member, which can be mounted on a vehicle.

Normal occupant weight

This means 68 kilograms (150 lbs.) times the number of occupants specified in the second column of Table I of 49 CFR 571.110.

Occupant distribution

The distribution of occupants in a vehicle as specified in the third column of Table I of 49 CFR 571.110.

Open splice

Any parting at any junction of tread, sidewall, or innerliner that extends to cord material.

Outer diameter

The overall diameter of an inflated new tire.

Overall width

The linear distance between the exteriors of the sidewalls of an inflated tire, including elevations due to labeling, decorations, or protective bands or ribs.

Ply

A layer of rubber-coated parallel cords.

Ply separation

A parting of rubber compound between adjacent plies.

Pneumatic tire

A mechanical device made of rubber, chemicals, fabric and steel or other materials, that, when mounted on an automotive wheel, provides the traction and contains the gas or fluid that sustains the load.

Production options weight

The combined weight of those installed regular production options weighing over 2.3 kilograms (5 lbs.) in excess of those standard items which they replace, not previously considered in curb weight or accessory weight, including heavy duty brakes, ride levelers, roof rack, heavy duty battery, and special trim.

Radial ply tire

A pneumatic tire in which the ply cords that extend to the beads are laid at substantially 90 degrees to the centerline of the tread.

Recommended inflation pressure

This is the inflation pressure provided by the vehicle manufacturer on the Tire Information label and on the Certification / VIN tag.

Reinforced tire

A tire designed to operate at higher loads and at higher inflation pressures than the corresponding standard tire.

Rim

A metal support for a tire or a tire and tube assembly upon which the tire beads are seated.

Rim diameter

This means the nominal diameter of the bead seat.

Rim size designation

This means the rim diameter and width.

Rim type designation

This means the industry of manufacturer's designation for a rim by style or code.

Rim width

This means the nominal distance between rim flanges.

Section width

The linear distance between the exteriors of the sidewalls of an inflated tire, excluding elevations due to labeling, decoration, or protective bands.

Sidewall

That portion of a tire between the tread and bead.

Sidewall separation

The parting of the rubber compound from the cord material in the sidewall.

Special Trailer (ST) tire

The "ST" is an indication the tire is for trailer use only.

Test rim

The rim on which a tire is fitted for testing, and may be any rim listed as appropriate for use with that tire.

Tread

That portion of a tire that comes into contact with the road.

Tire Safety Information

Tread rib

A tread section running circumferentially around a tire.

Tread separation

Pulling away of the tread from the tire carcass.

Treadwear indicators (TWI)

The projections within the principal grooves designed to give a visual indication of the degrees of wear of the tread.

Vehicle capacity weight

The rated cargo and luggage load plus 68 kilograms (150 lbs.) times the vehicle's designated seating capacity.

Vehicle maximum load on the tire

The load on an individual tire that is determined by distributing to each axle its share of the maximum loaded vehicle weight and dividing by two.

Vehicle normal load on the tire

The load on an individual tire that is determined by distributing to each axle its share of the curb weight, accessory weight, and normal occupant weight (distributed in accordance with Table I of CRF 49 571.110) and dividing by 2.

Weather side

The surface area of the rim not covered by the inflated tire.

Wheel center member

In the case of a non-pneumatic tire assembly incorporating a wheel, a mechanical device which attaches, either integrally or separably, to the non-pneumatic rim and provides the connection between the non-pneumatic rim and the vehicle; or, in the case of a non-pneumatic tire assembly not incorporating a wheel, a mechanical device which attaches, either integrally or separably, to the non-pneumatic tire and provides the connection between tire and the vehicle.

Wheel-holding fixture

The fixture used to hold the wheel and tire assembly securely during testing.

1.4. TIRE SAFETY - EVERYTHING RIDES ON IT

The National Traffic Safety Administration (NHTSA) has published a brochure (DOT HS 809 361) that discusses all aspects of Tire Safety, as required by CFR 575.6. This brochure is reproduced in part below. It can be obtained and downloaded from NHTSA, free of charge, from the following web site:

http://www.nhtsa.dot.gov/cars/rules/TireSafety/ridesonit/tires_index.html

Studies of tire safety show that maintaining proper tire pressure, observing tire and vehicle load limits (not carrying more weight in your vehicle than your tires or vehicle can safely handle), avoiding road hazards, and inspecting tires for cuts, slashes, and other irregularities are the most important things you can do to avoid tire failure, such as tread separation or blowout and flat tires. These actions, along with other care and maintenance activities, can also:

- Improve vehicle handling
- Help protect you and others from avoidable breakdowns and accidents
- Improve fuel economy
- Increase the life of your tires.

This booklet presents a comprehensive overview of tire safety, including information on the following topics:

- Basic tire maintenance
- Uniform Tire Quality Grading System
- Fundamental characteristics of tires

- Tire safety tips.

Use this information to make tire safety a regular part of your vehicle maintenance routine. Recognize that the time you spend is minimal compared with the inconvenience and safety consequences of a flat tire or other tire failure.

1.5. SAFETY FIRST—BASIC TIRE MAINTENANCE

Properly maintained tires improve the steering, stopping, traction, and load-carrying capability of your vehicle. Underinflated tires and overloaded vehicles are a major cause of tire failure. Therefore, as mentioned above, to avoid flat tires and other types of tire failure, you should maintain proper tire pressure, observe tire and vehicle load limits, avoid road hazards, and regularly inspect your tires.

1.5.1. FINDING YOUR VEHICLE'S RECOMMENDED TIRE PRESSURE AND LOAD LIMITS

Tire information placards and vehicle certification labels contain information on tires and load limits. These labels indicate the vehicle manufacturer's information including:

- Recommended tire size
- Recommended tire inflation pressure
- Vehicle capacity weight (VCW—the maximum occupant and cargo weight a vehicle is designed to carry)
- Front and rear gross axle weight ratings (GAWR—the maximum weight the axle systems are designed to carry).

Both placards and certification labels are permanently attached to the trailer near the left front.

1.5.2. UNDERSTANDING TIRE PRESSURE AND LOAD LIMITS

Tire inflation pressure is the level of air in the tire that provides it with load-carrying capacity and affects the overall performance of the vehicle. The tire inflation pressure is a number that indicates the amount of air pressure—measured in pounds per square inch (psi)—a tire requires to be properly inflated. (You will also find this number on the vehicle information placard expressed in kilopascals (kpa), which is the metric measure used internationally.)

Manufacturers of passenger vehicles and light trucks determine this number based on the vehicle's design load limit, that is, the greatest amount of weight a vehicle can safely carry and the vehicle's tire size. The proper tire pressure for your vehicle is referred to as the "recommended cold inflation pressure." (As you will read below, it is difficult to obtain the recommended tire pressure if your tires are not cold.)

Because tires are designed to be used on more than one type of vehicle, tire manufacturers list the "maximum permissible inflation pressure" on the tire sidewall. This number is the greatest amount of air pressure that should ever be put in the tire under normal driving conditions.

1.5.3. CHECKING TIRE PRESSURE

It is important to check your vehicle's tire pressure at least once a month for the following reasons:

- Most tires may naturally lose air over time.
- Tires can lose air suddenly if you drive over a pothole or other object or if you strike the curb when parking.
- With radial tires, it is usually not possible to determine underinflation by visual inspection.

For convenience, purchase a tire pressure gauge to keep in your vehicle. Gauges can be purchased at tire dealerships, auto supply stores, and other retail outlets.

The recommended tire inflation pressure that vehicle manufacturers provide reflects the proper psi when a tire is cold. The term cold does not relate to the outside temperature. Rather, a cold tire is one that has not been driven on for at least three hours. When you drive, your tires get warmer, causing the air pressure within them to increase. Therefore, to get an accurate tire pressure reading, you must measure tire pressure when the tires are cold or compensate for the extra pressure in warm tires.

Tire Safety Information

1.5.4. STEPS FOR MAINTAINING PROPER TIRE PRESSURE

- Step 1: Locate the recommended tire pressure on the vehicle's tire information placard, certification label, or in the owner's manual.
- Step 2: Record the tire pressure of all tires.
- Step 3: If the tire pressure is too high in any of the tires, slowly release air by gently pressing on the tire valve stem with the edge of your tire gauge until you get to the correct pressure.
- Step 4: If the tire pressure is too low, note the difference between the measured tire pressure and the correct tire pressure. These "missing" pounds of pressure are what you will need to add.
- Step 5: At a service station, add the missing pounds of air pressure to each tire that is underinflated.
- Step 6: Check all the tires to make sure they have the same air pressure (except in cases in which the front and rear tires are supposed to have different amounts of pressure).

If you have been driving your vehicle and think that a tire is underinflated, fill it to the recommended cold inflation pressure indicated on your vehicle's tire information placard or certification label. While your tire may still be slightly underinflated due to the extra pounds of pressure in the warm tire, it is safer to drive with air pressure that is slightly lower than the vehicle manufacturer's recommended cold inflation pressure than to drive with a significantly underinflated tire. Since this is a temporary fix, don't forget to recheck and adjust the tire's pressure when you can obtain a cold reading.

1.5.5. TIRE SIZE

To maintain tire safety, purchase new tires that are the same size as the vehicle's original tires or another size recommended by the manufacturer. Look at the tire information placard, the owner's manual, or the sidewall of the tire you are replacing to find this information. If you have any doubt about the correct size to choose, consult with the tire dealer.

1.5.6. TIRE TREAD

The tire tread provides the gripping action and traction that prevent your vehicle from slipping or sliding, especially when the road is wet or icy. In general, tires are not safe and should be replaced when the tread is worn down to 1/16 of an inch. Tires have built-in treadwear indicators that let you know when it is time to replace your tires. These indicators are raised sections spaced intermittently in the bottom of the tread grooves. When they appear "even" with the outside of the tread, it is time to replace your tires. Another method for checking tread depth is to place a penny in the tread with Lincoln's head upside down and facing you. If you can see the top of Lincoln's head, you are ready for new tires.

1.5.7. TIRE BALANCE AND WHEEL ALIGNMENT

To avoid vibration or shaking of the vehicle when a tire rotates, the tire must be properly balanced. This balance is achieved by positioning weights on the wheel to counterbalance heavy spots on the wheel-and-tire assembly. A wheel alignment adjusts the angles of the wheels so that they are positioned correctly relative to the vehicle's frame. This adjustment maximizes the life of your tires. These adjustments require special equipment and should be performed by a qualified technician.

1.5.8. TIRE REPAIR

The proper repair of a punctured tire requires a plug for the hole and a patch for the area inside the tire that surrounds the puncture hole. Punctures through the tread can be repaired if they are not too large, but punctures to the sidewall should not be repaired. Tires must be removed from the rim to be properly inspected before being plugged and patched.

1.5.9. TIRE FUNDAMENTALS

Federal law requires tire manufacturers to place standardized information on the sidewall of all tires. This information identifies and describes the fundamental characteristics of the tire and also provides a tire identification number for safety standard certification and in case of a recall.

1.5.9.1. Information on Passenger Vehicle Tires

Please refer to the diagram below.



P

The "P" indicates the tire is for passenger vehicles.

Next number

This three-digit number gives the width in millimeters of the tire from sidewall edge to sidewall edge. In general, the larger the number, the wider the tire.

Next number

This two-digit number, known as the aspect ratio, gives the tire's ratio of height to width. Numbers of 70 or lower indicate a short sidewall for improved steering response and better overall handling on dry pavement.

R

The "R" stands for radial. Radial ply construction of tires has been the industry standard for the past 20 years.

Next number

This two-digit number is the wheel or rim diameter in inches. If you change your wheel size, you will have to purchase new tires to match the new wheel diameter.

Next number

This two- or three-digit number is the tire's load index. It is a measurement of how much weight each tire can support. You may find this information in your owner's manual. If not, contact a local tire dealer. Note: You may not find this information on all tires because it is not required by law.

M+S

The "M+S" or "M/S" indicates that the tire has some mud and snow capability. Most radial tires have these markings; hence, they have some mud and snow capability.

Speed Rating

The speed rating denotes the speed at which a tire is designed to be driven for extended periods of time. The ratings range from 99 miles per hour (mph) to 186 mph. These ratings are listed below. Note: You may not find this information on all tires because it is not required by law.

Tire Safety Information

Tire Safety Information

Letter Rating	Speed Rating
Q	99 mph
R	106 mph
S	112 mph
T	118 mph
U	124 mph
H	130 mph
V	149 mph
W	168* mph
Y	186* mph

* For tires with a maximum speed capability over 149 mph, tire manufacturers sometimes use the letters ZR. For those with a maximum speed capability over 186 mph, tire manufacturers always use the letters ZR.

U.S. DOT Tire Identification Number

This begins with the letters "DOT" and indicates that the tire meets all federal standards. The next two numbers or letters are the plant code where it was manufactured, and the last four numbers represent the week and year the tire was built. For example, the numbers 3197 means the 31st week of 1997. The other numbers are marketing codes used at the manufacturer's discretion. This information is used to contact consumers if a tire defect requires a recall.

Tire Ply Composition and Materials Used

The number of plies indicates the number of layers of rubber-coated fabric in the tire. In general, the greater the number of plies, the more weight a tire can support. Tire manufacturers also must indicate the materials in the tire, which include steel, nylon, polyester, and others.

Maximum Load Rating

This number indicates the maximum load in kilograms and pounds that can be carried by the tire.

Maximum Permissible Inflation Pressure

This number is the greatest amount of air pressure that should ever be put in the tire under normal driving conditions.

1.5.9.2. UTQGS Information

Treadwear Number

This number indicates the tire's wear rate. The higher the treadwear number is, the longer it should take for the tread to wear down. For example, a tire graded 400 should last twice as long as a tire graded 200.

Traction Letter

This letter indicates a tire's ability to stop on wet pavement. A higher graded tire should allow you to stop your car on wet roads in a shorter distance than a tire with a lower grade. Traction is graded from highest to lowest as "AA", "A", "B", and "C".

Temperature Letter

This letter indicates a tire's resistance to heat. The temperature grade is for a tire that is inflated properly and not overloaded. Excessive speed, underinflation or excessive loading, either separately or in combination, can cause heat build-up and possible tire failure. From highest to lowest, a tire's resistance to heat is graded as "A", "B", or "C".

1.5.9.3. Additional Information on Light Truck Tires

Please refer to the following diagram.

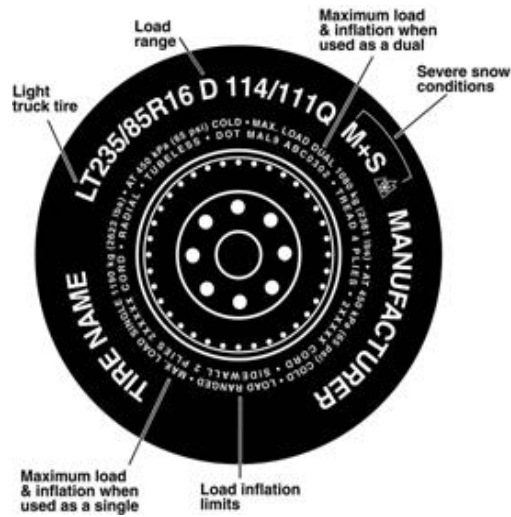

Tires for light trucks have other markings besides those found on the sidewalls of passenger tires.

LT

The "LT" indicates the tire is for light trucks or trailers.

ST

An "ST" is an indication the tire is for trailer use only.

Max. Load Dual kg (lbs) at kPa (psi) Cold

This information indicates the maximum load and tire pressure when the tire is used as a dual, that is, when four tires are put on each rear axle (a total of six or more tires on the vehicle).

Max. Load Single kg (lbs) at kPa (psi) Cold

This information indicates the maximum load and tire pressure when the tire is used as a single.

Load Range

This information identifies the tire's load-carrying capabilities and its inflation limits.

1.6. TIRE SAFETY TIPS

Preventing Tire Damage

- Slow down if you have to go over a pothole or other object in the road.
- Do not run over curbs or other foreign objects in the roadway, and try not to strike the curb when parking.

Tire Safety Checklist

- Check tire pressure regularly (at least once a month), including the spare.
- Inspect tires for uneven wear patterns on the tread, cracks, foreign objects, or other signs of wear or trauma.
- Remove bits of glass and foreign objects wedged in the tread.
- Make sure your tire valves have valve caps.
- Check tire pressure before going on a long trip.
- Do not overload your vehicle. Check the Tire Information and Loading Placard or User's Manual for the maximum recommended load for the vehicle.

User's Information for Transport Canada Fuel Tank

22 User's Information for Transport Canada Fuel Tank

Note: *The following information applies ONLY to machines equipped with a Transport Canada fuel tank. This type of fuel tank is required for machines transported on Canadian roads. Contact your Wacker Neuson dealer if you are unsure about whether or not your machine is approved for use in Canada.*

Description The fuel tank, or Intermediate Bulk Container (IBC), on this machine was designed for the storage and transportation of diesel fuel when mounted on a mobile electric power source as a sub-base tank.

The fuel tank was manufactured using ductile steel which meets or exceeds United Nations specifications (eg. CGSB 43-146-2002 in Canada). It has been tested and certified as UN Standard Mobile IBC, 31A/Y Packing Group II and III. This is an international standard recognized by the Canadian Transportation of Dangerous Goods Act (TDG), and it applies to tanks either made in Canada or imported (TDG Regs. 5.6(b)).

The fuel tank is equipped with a pressure / vacuum relief venting device set to 2 psi (14 kPa) pressure and 0.25 psi (1.75 kPa) vacuum.

General requirements

- Do not fill above 95% maximum capacity of the fuel tank.
- All valves and plugs must be closed while the machine is being transported.

Placarding requirements Immediately after the fuel tank is filled (fully or partially) with flammable liquids, UN Placards / Transport of Dangerous Goods Decals / Placards of Flammable Liquids (Transport Canada - Product Identification Decals) must be installed prior to moving the machine in any manner. This is a requirement of Transport Canada.

Refer to "Hazardous Materials Placards" in the *Operation* chapter for instructions on how to install the placards.

Maintaining the fuel tank

- The fuel tank must not be lifted or moved with any fuel inside. Drain the fuel tank completely and remove external hardware before relocating the tank for inspection or maintenance.
- Do not drill into, or weld anything onto, the fuel tank.
- Inspect the exterior paint annually for chips or scratches. Repair any damage using compatible paint.
- Replacement of damaged components or parts must be of the same specification or equivalent. Replacement parts can be obtained directly from Wacker Neuson or from an authorized Wacker Neuson service center.

Compulsory inspections Transport of Dangerous Goods / Transport Canada regulations require the fuel tank to be leak tested and inspected every 5 years (60 months) at a certified facility. A list of testing facilities in Canada certified to perform leak tests and inspections can be found at the Transport Canada website:

http://www.tc.gc.ca/tdg/containers/ibc_leak/ibcleak.asp

The following pages contain forms for you to record tank inspection and testing results. Copy the pages as needed.

User's Information for Transport Canada Fuel Tank

TANK INSPECTION & TESTING RECORD - FORMS

Keep track of all future tank inspections and Leak Testing Reports. Make copies of the next two pages for your records. The future Leak Test shall be marked with letter "R" followed by the month and year of the Leak Test & Inspection followed with the Certificate of Registration Number of the leak test facility on the UN Decal Plate mounted on the Fuel Tank.

Model No.	Owners Ref No.	<u>RECORD CARD</u> THIS RECORD CARD MUST BE KEPT WITH THE GENSET BY THE OWNER / USER, READY FOR INSPECTION AT ALL TIMES
Serial No.		
Capacity		
Date		
Owner:	This Sub-Base Fuel Tank on this Electric GenSet is a UN Approved IBC, Packing Group III. It was leak tested at the time of manufacturing, and the month and year recorded on the UN Decal / Metal Specification Tag mounted on the Decal Plate at the Top Panel of the Tank. A leak test & inspection is required every 60-months by a facility registered with Transport Canada.	

Date of Re-Test:	_____
Name of Testing Facility:	_____
Registration Number:	_____
Address:	_____
TEST RESULTS:	
EXTERNAL TESTING:	_____
INTERNAL TESTING:	_____
COMPONENTS:	_____
Date of Next Test:	

User's Information for Transport Canada Fuel Tank

Date of Re-Test:	_____
Name of Testing Facility:	_____
Registration Number:	_____
Address:	_____
TEST RESULTS:	
EXTERNAL TESTING:	_____
INTERNAL TESTING:	_____
COMPONENTS:	_____
	Date of Next Re-Test:

Date of Re-Test:	_____
Name of Testing Facility:	_____
Registration Number:	_____
Address:	_____
TEST RESULTS:	
EXTERNAL TESTING:	_____
INTERNAL TESTING:	_____
COMPONENTS:	_____
	Date of Next Re-Test:

Date of Re-Test:	_____
Name of Testing Facility:	_____
Registration Number:	_____
Address:	_____
TEST RESULTS:	
EXTERNAL TESTING:	_____
INTERNAL TESTING:	_____
COMPONENTS:	_____

23 Emission Control Systems Information and Warranty—Diesel

The Emission Control Warranty and associated information is valid only for the U.S.A., its territories, and Canada.

23.1 Emission Control System Background Information

Introduction

Wacker Neuson engines/equipment must conform with applicable Environmental Protection Agency (EPA) and California Air Resource Board (CARB) emissions regulations. These regulations require that manufacturers warrant the emission control systems for defects in materials and workmanship.

Furthermore, EPA and CARB regulations require all manufacturers to furnish written instructions describing how to operate and maintain the engines/equipment including the emission control systems. This information is provided with all Wacker Neuson engines/equipment at the time of purchase.

Exhaust Emissions

The combustion process produces carbon monoxide, oxides of nitrogen, and hydrocarbons. Control of hydrocarbons and oxides of nitrogen is very important because, under certain conditions, they react to form photochemical smog when subjected to sunlight. Carbon monoxide does not react in the same way, but it is toxic.

Problems that may affect Emissions

If any of the following symptoms arise, have the engine/equipment inspected and repaired by a Wacker Neuson dealer/service center.

- Hard starting or stalling after starting
 - Rough idling
 - Misfiring or backfiring under load
 - Afterburning (backfiring)
 - Presence of black exhaust smoke during operation
 - High fuel consumption
-

Tampering and Altering

Tampering with or altering the emission control system may increase emissions beyond the legal limit. If evidence of tampering is found, Wacker Neuson may deny a warranty claim. Among those acts that constitute tampering are:

- Removing or altering of any part of the air intake, fuel, or exhaust systems.
- Altering or defeating the speed-adjusting mechanism causing the engine to operate outside its design parameters.

23.2 Limited Defect Warranty for Exhaust Emission Control System

Emission Control Systems Information and Warranty—Diesel

See the supplied engine owner's manual for the applicable emission warranty statement.

23.3 Limited Defect Warranty for Wacker Neuson Emission Control Systems

The Emission Control Warranty is valid only for the U.S.A., its territories, and Canada.

Wacker Neuson America, N92 W15000 Anthony Avenue, Menomonee Falls, WI 53051, (hereinafter "Wacker Neuson") warrants to the initial retail purchaser and each subsequent owner, that this engine/equipment, including all parts of its emission control system, have been designed, built, and equipped to conform at the time of initial sale to all applicable evaporative emission regulations of the U.S. Environmental Protection Agency (EPA), and that the engine/equipment is free of defects in materials and workmanship which would cause this engine/equipment to fail to conform to EPA regulations during its warranty period.

Wacker Neuson is also liable for damages to other engine/equipment components caused by a failure of any warranted parts during the warranty period.

What is covered

Wacker Neuson recommends the use of genuine Wacker Neuson parts, or the equivalent, whenever maintenance is performed. The use of replacement parts not equivalent to the original parts may impair the effectiveness of the engine/equipment emission controls systems. If such a replacement part is used in the repair or maintenance of the engine/equipment, assure yourself that such part is warranted by its manufacturer to be equivalent to the parts offered by Wacker Neuson in performance and durability. Furthermore, if such a replacement part is used in the repair or maintenance of the engine/equipment, and an authorized Wacker Neuson dealer/service center determines it is defective or causes a failure of a warranted part, the claim for repair of the engine/equipment may be denied. If the part in question is not related to the reason the engine/equipment requires repair, the claim will not be denied.

For the components listed in the following table, an authorized Wacker Neuson dealer/service center will, at no cost to you, make the necessary diagnosis, repair, or replacement necessary to ensure that the engine/equipment complies with the applicable EPA regulations. All defective parts replaced under this warranty become property of Wacker Neuson.

System Covered	Components
Air handling system and associated plumbing	Charge air cooler
	Charge air cooler plumbing
Exhaust system (upstream of last after treatment device)	Exhaust gas piping from turbocharger out to the last after treatment device

What is not covered

- Failures other than those resulting from defects in material or workmanship.

Emission Control Systems Information and Warranty—Diesel

- Any systems or parts which are affected or damaged by owner abuse, tampering, neglect, improper maintenance, misuse, improper fueling, improper storage, accident and/or collision; the incorporation of, or any use of, add-on or modified parts, or unsuitable attachments, or the alteration of any part.
 - Replacement of expendable maintenance items made in connection with required maintenance services after the item's first scheduled replacement as listed in the maintenance section of the engine/equipment operator's manual, such as spark plugs and filters.
 - Incidental or consequential damages such as loss of time or the use of the engine/equipment, or any commercial loss due to the failure of the engine/equipment.
 - Diagnosis and inspection charges that do not result in warranty-eligible service being performed.
 - Any non-authorized replacement part, or malfunction of authorized parts due to use of non-authorized parts.
-

Owner's Warranty Responsibility

The engine/equipment owner, is responsible for the performance of the required maintenance listed in the Wacker Neuson engine/equipment operator's manual. Wacker Neuson recommends that all receipts covering maintenance on the engine/equipment be retained, but Wacker Neuson cannot deny warranty coverage solely for the lack of receipts or for the failure to ensure the performance of all scheduled maintenance.

Normal maintenance, replacement, or repair of emission control devices and systems may be performed by any repair establishment or individual; however, warranty repairs must be performed by an authorized Wacker Neuson dealer/service center.

The engine/equipment must be presented to an authorized Wacker Neuson dealer/service center as soon as a problem exists. Contact Wacker Neuson Product Support Department (1-800-770-0957) or visit wackerneuson.com to find a dealer/service center in your area, or to answer questions regarding warranty rights and responsibilities.

How to Make a Claim

In the event that any emission-related part is found to be defective during the warranty period, you shall notify Wacker Neuson Product Support Department (1-800-770-0957, or technical.support@wackerneuson.com, or wackerneuson.com), and you will be advised of the appropriate dealer/service center where warranty repair can be performed. All repairs qualifying under this limited warranty must be performed by an authorized Wacker Neuson dealer/service center.

You must take your Wacker Neuson engine/equipment along with proof of original purchase date, at your expense, to the authorized Wacker Neuson dealer/service center during their normal business hours.

For owners located more than 100 miles from an authorized dealer/service center (excluding the states with high-altitude areas as identified in 40 CFR Part 1068,

Emission Control Systems Information and Warranty—Diesel

Appendix III), Wacker Neuson will pay for pre-approved shipping costs to and from an authorized Wacker Neuson dealer/service center.

Claims for repair or adjustment found to be caused solely by defects in material or workmanship will not be denied because the engine/equipment was not properly maintained and used.

The warranty repairs should be completed in a reasonable amount of time, not to exceed 30 days.

This page is intentionally left blank.

24.1 Fuses

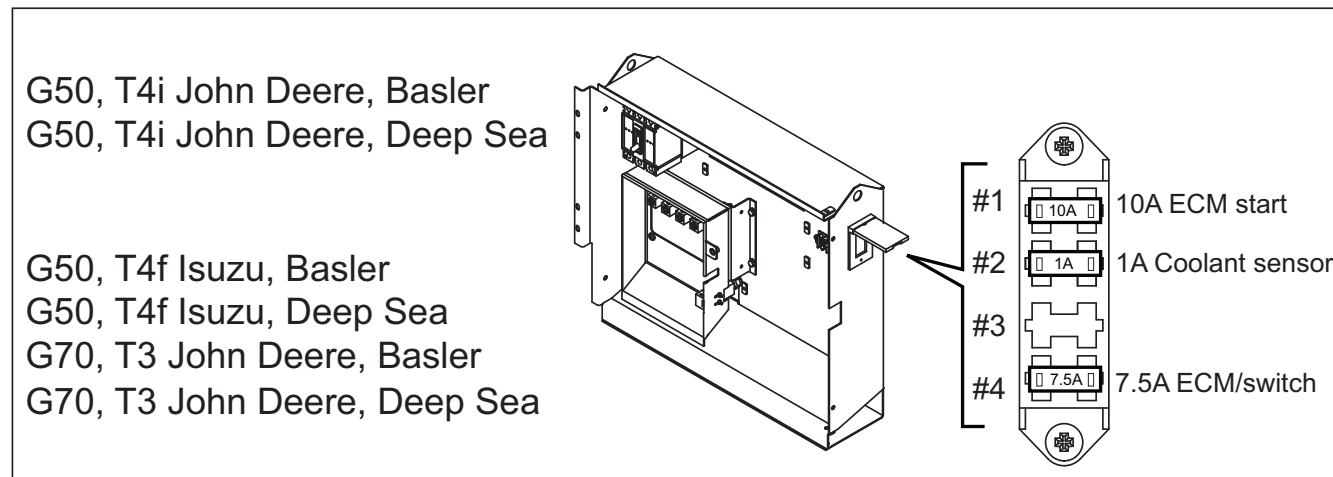

wc_gr014905

24.2 Trailer Wiring

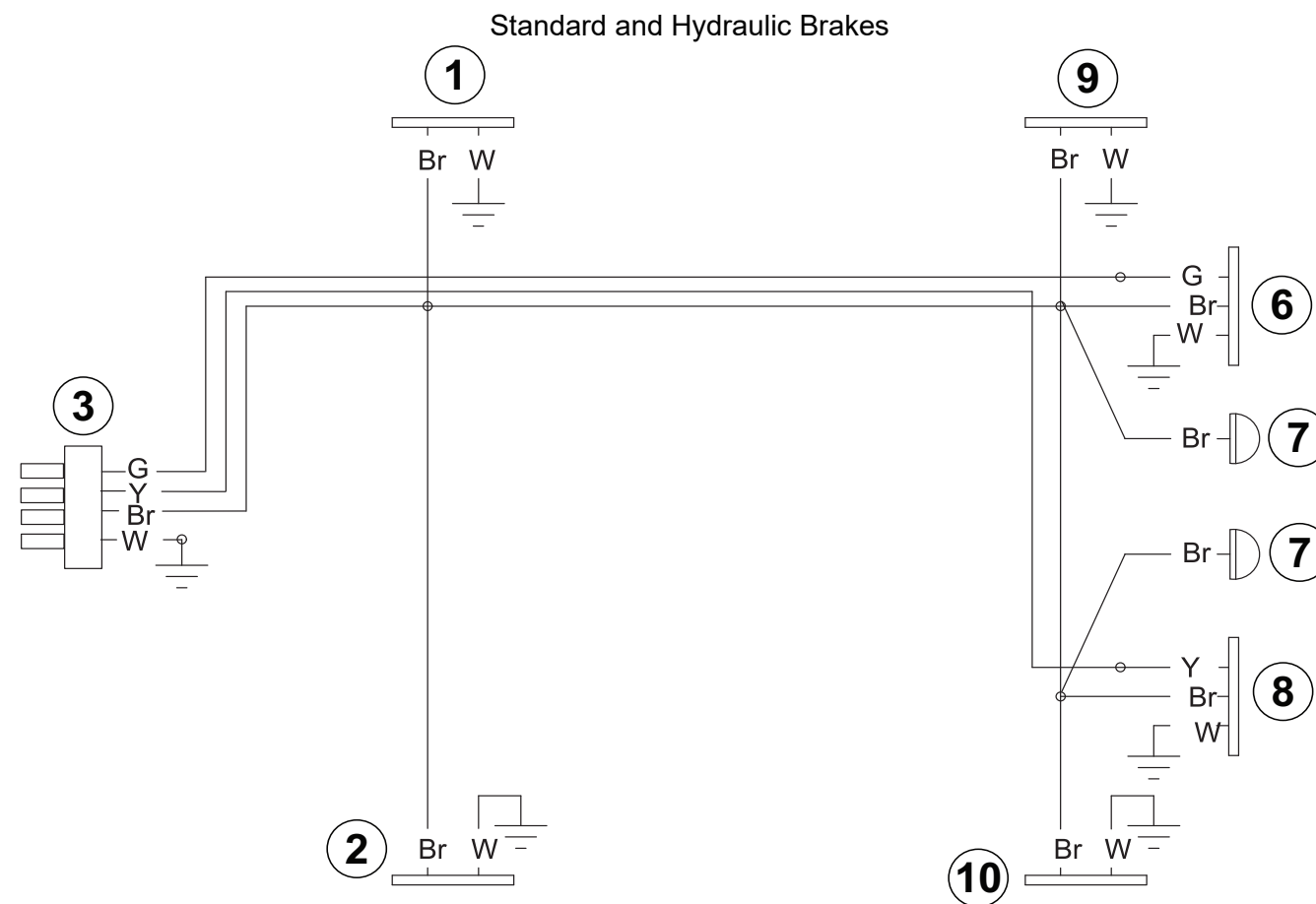

wc_gr000522

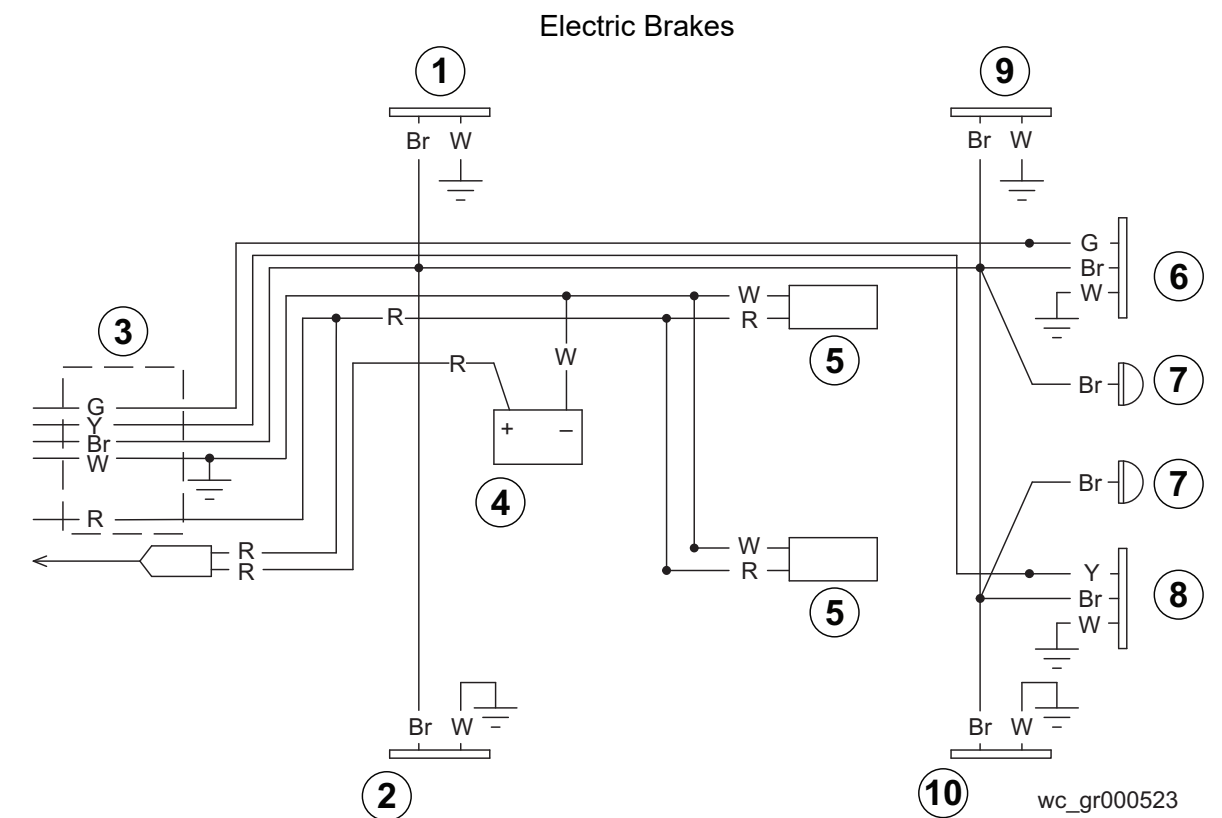

wc_gr000523

24.3 Trailer Wiring Components

Ref.	Description
1	Front right side amber light
2	Front left side amber light
3	Trailer plug
4	Battery
5	Brake solenoid
6	Right tail light
7	License plate holder lights
8	Left tail light
9	Rear right side red light
10	Rear left side red light

Ref.	Wire Colors	Rear Lights	Side Lights	Harness
B	Black	Ground	Ground	Battery charge
Br	Brown	Tail light	—	Tail, side, and license plate
L	Blue	—	—	—
R	Red	Brake light	Power	Electric brakes
Y	Yellow	—	—	Left brake light and directional
G	Green	—	—	Right brake light and directional
W	White	—	—	Ground

25 Schematics—Machines with Basler Controller

25.1 AC Schematic

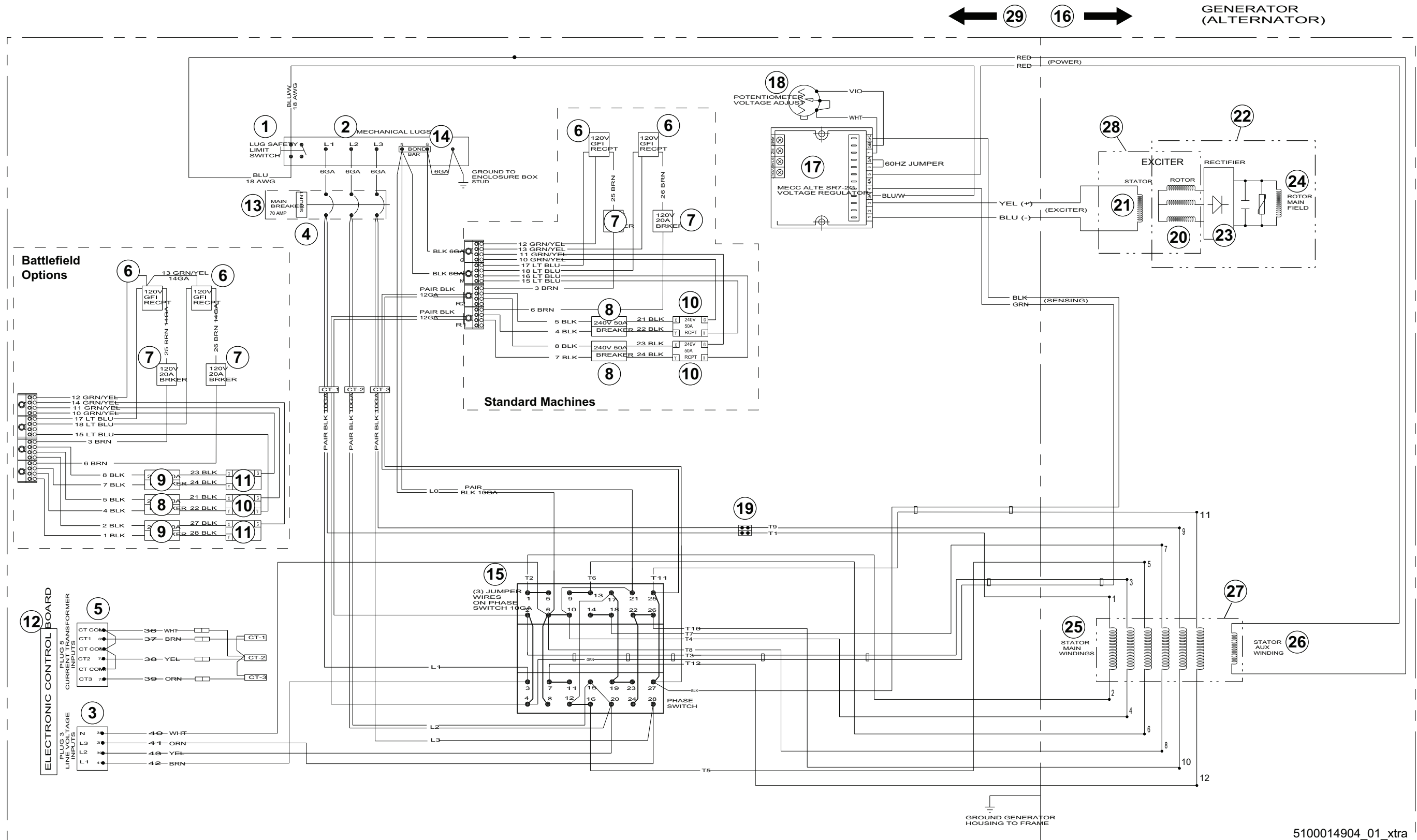

5100014904_01_xtra

25.2 AC Schematic Components

Ref.	Description	Ref.	Description
1	Lug safety limit switch	16	Generator
2	Mechanical lugs	17	Voltage regulator with 4A fuse
3	Plug 4—line voltage inputs	18	Voltage adjustment rheostat
4	Plug 5—current transformer inputs	19	Terminal block
5	Shunt	20	Exciter rotor windings
6	120V GFI receptacle	21	Exciter stator winding
7	120V 20A breaker	22	Rotor
8	240V 50A breaker	23	Rectifier (diodes)
9	240V 20A breaker (optional)	24	Main rotor winding
10	240V 50A receptacle	25	Main stator windings
11	240V 20A receptacle (optional)	26	Auxiliary stator winding
12	Engine control module	27	Stator
13	Main breaker	28	Exciter
14	Bus bar	29	Machine
15	Voltage selector switch	—	—

Wire Colors							
BLK	Black	RED	Red	WHT	White	ORG	Orange
GRN	Green	TAN	Tan	YEL	Yellow	BRN	Brown
BLU	Blue	VIO	Violet	GRY	Gray	PNK	Pink

25.3 DC Schematic: G25, T4i Isuzu, Basler

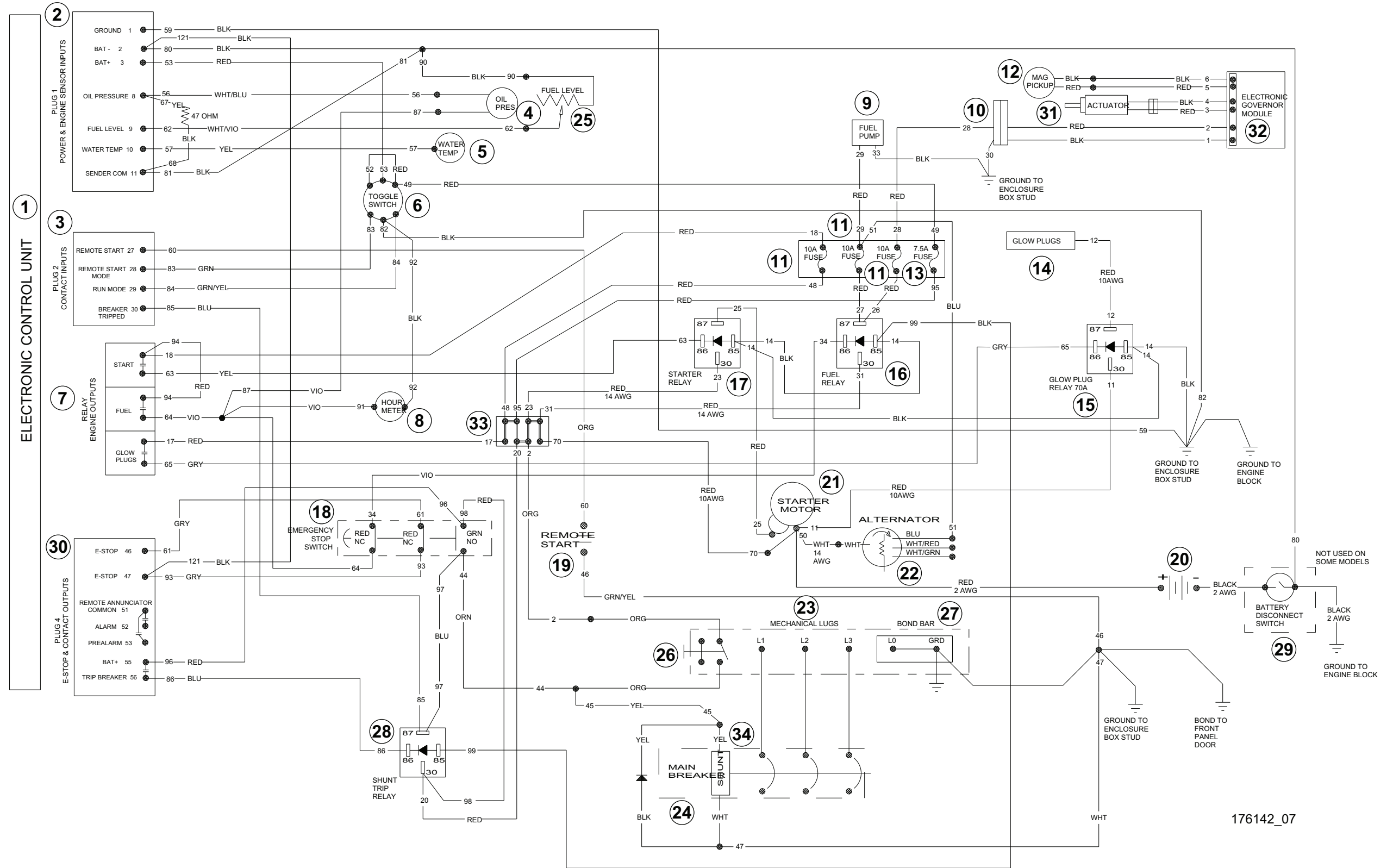

25.4 DC Schematic Components: G25, T4i Isuzu, Basler

Ref.	Description	Ref.	Description
1	Electronic control unit (genset controller)	15	Glow plug relay
2	Plug 1 - power and engine sender inputs	16	Fuel relay
	Ground	17	Starter relay
	Bat -	18	Emergency stop switch
	Bat +	19	Remote start terminals
	Oil pressure	20	Battery
	Fuel level	21	Starter motor
	Water temp	22	Alternator
	Sender com	23	Mechanical lugs
3	Plug 2 - contact inputs	24	Main circuit breaker
	Remote start	25	Fuel level sender
	Remote start mode	26	Lug door interlock switch
	Run mode	27	Bond bar
	Breaker tripped	28	Shunt trip relay
4	Oil pressure sender	29	Battery disconnect (optional)
5	Water temperature sender	30	Plug 4 - E-stop & contact outputs
6	Toggle switch (Remote start / Off / Start / Run)		E-stop
7	Relay - engine outputs		E-stop
	Start		Remote annunciator common
	Fuel		Alarm
	Glow plugs		Prealarm
8	Hour meter		Bat +
9	Fuel pump		Trip Breaker
10	Connector	31	Actuator
11	10A fuse	32	Electronic governor module
12	Magnetic pickup	33	Terminal strip
13	7.5A fuse	34	Shunt
14	Glow plugs	—	—

Wire Colors							
BLK	Black	RED	Red	WHT	White	ORG	Orange
GRN	Green	TAN	Tan	YEL	Yellow	BRN	Brown
BLU	Blue	VIO	Violet	GRY	Gray	PNK	Pink

25.5 DC Schematic: G25, T4f Isuzu, Basler

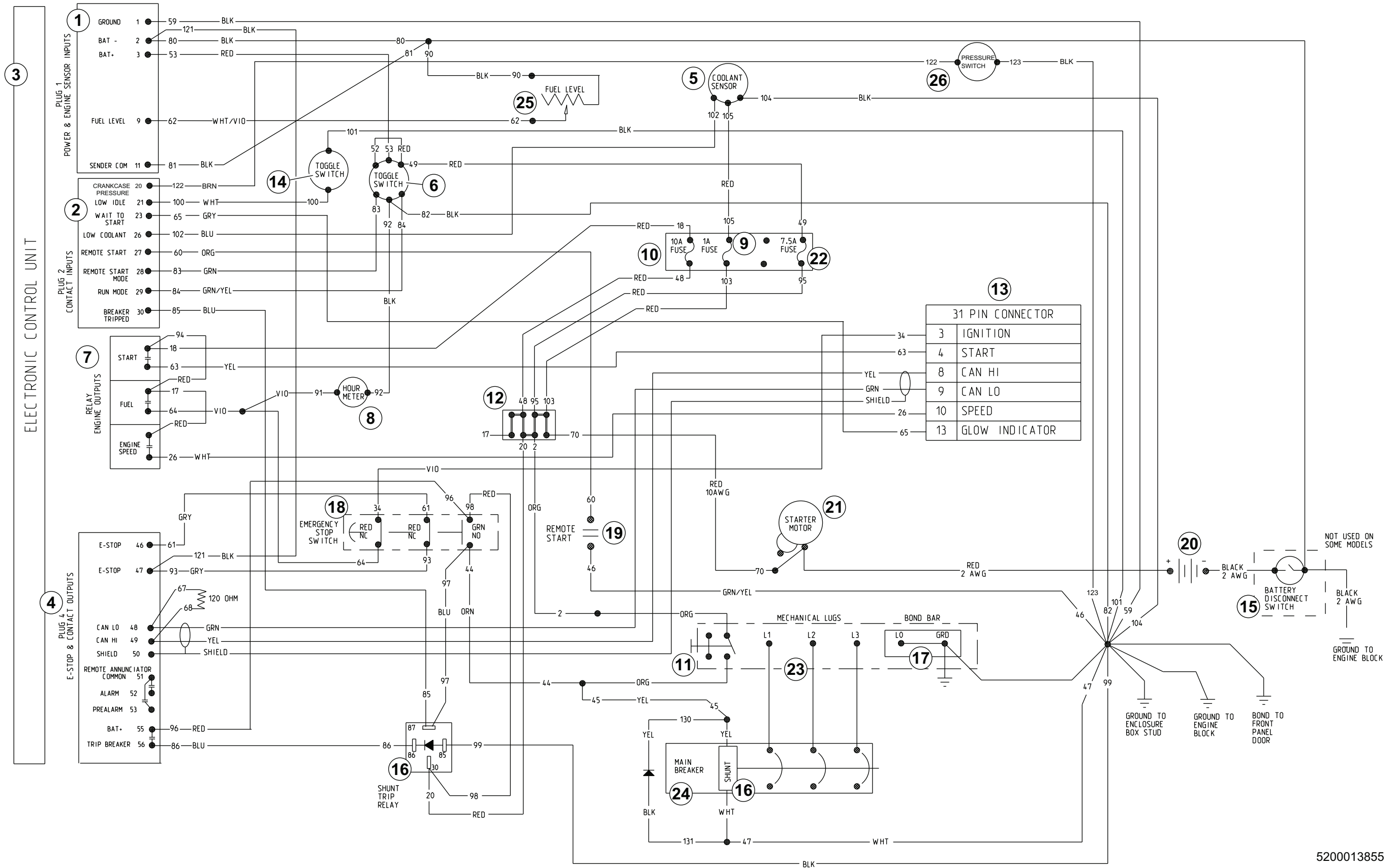

3

5200013855

25.6 DC Schematic Components: G25, T4f Isuzu, Basler

Ref.	Description	Ref.	Description
1	Plug 1 - power and engine sender inputs	7	Relay - engine outputs
	Ground		Start
	Bat -		Fuel
	Bat +		Engine speed
2	Fuel level	8	Hour meter
	Sender com	9	1A fuse
	Plug 2 - contact inputs	10	10A fuse
	Crankcase pressure	11	Lug door interlock switch
	Low idle	12	Terminal strip
	Wait to start	13	Engine connector
	Low coolant		Ignition
	Remote start		Start
	Remote start mode		Can Hi
	Run mode		Can Lo
	Breaker tripped		Speed
	3	Electronic control unit (genset controller)	
4	Plug 4 - E-stop and contact outputs	14	Toggle switch
	E-stop	15	Battery disconnect (optional)
	E-stop	16	Shunt trip relay
	Can L	17	Bond bar
	Can H	18	Emergency stop switch
	Shield	19	Remote start terminals
	Remote annunciator common	20	Battery
	Alarm	21	Starter motor
	Prealarm	22	7.5A fuse
	Bat +	23	Mechanical lugs
	24	Main circuit breaker	
5	Coolant sensor	25	Fuel level sender
6	Toggle switch	26	Pressure switch

Wire Colors							
BLK	Black	RED	Red	WHT	White	ORG	Orange
GRN	Green	TAN	Tan	YEL	Yellow	BRN	Brown
BLU	Blue	VIO	Violet	GRY	Gray	PNK	Pink

25.7 AC Schematic G25, Isuzu, 600V, Basler

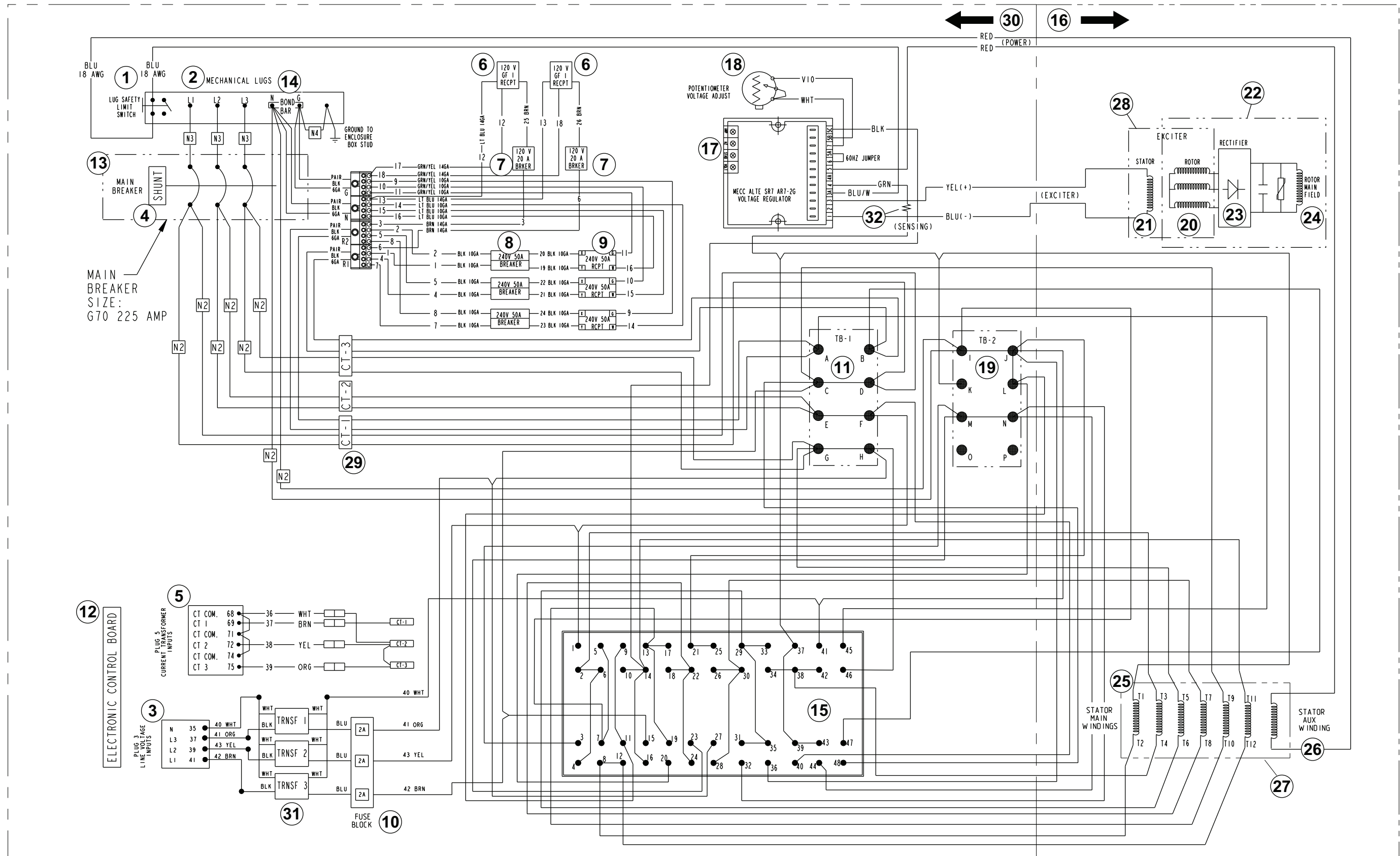

wc_gr011816

25.8 AC Schematic Components G25, Isuzu, 600V, Basler

Ref.	Description	Ref.	Description
1	Lug safety limit switch	17	Voltage regulator with 4A fuse
2	Mechanical lugs	18	Voltage adjustment rheostat
3	Plug 3 — line voltage inputs	19	Terminal block (2)
4	Shunt	20	Exciter rotor windings
5	Plug 5 — current transformer inputs	21	Exciter stator winding
6	120V GFCI receptacle	22	Rotor
7	120V 20A breaker	23	Rectifier (diodes)
8	240V 50A breaker	24	Main rotor winding
9	240V 50A receptacle	25	Main stator windings
10	Fuse box	26	Auxiliary stator winding
11	Terminal block (1)	27	Stator
12	Generator controller	28	Exciter
13	Main breaker	29	Current transformers
14	Bus bar (bond bar)	30	Machine and components
15	Voltage selector switch	31	Voltage transformers
16	Generator	32	Resistor 120k Ohms

Wire Colors							
BLK	Black	RED	Red	WHT	White	ORG	Orange
GRN	Green	TAN	Tan	YEL	Yellow	BRN	Brown
BLU	Blue	VIO	Violet	GRY	Gray	PNK	Pink

26 Schematics—Machines with Deep Sea Controller

26.1 AC Schematic: G25 480V

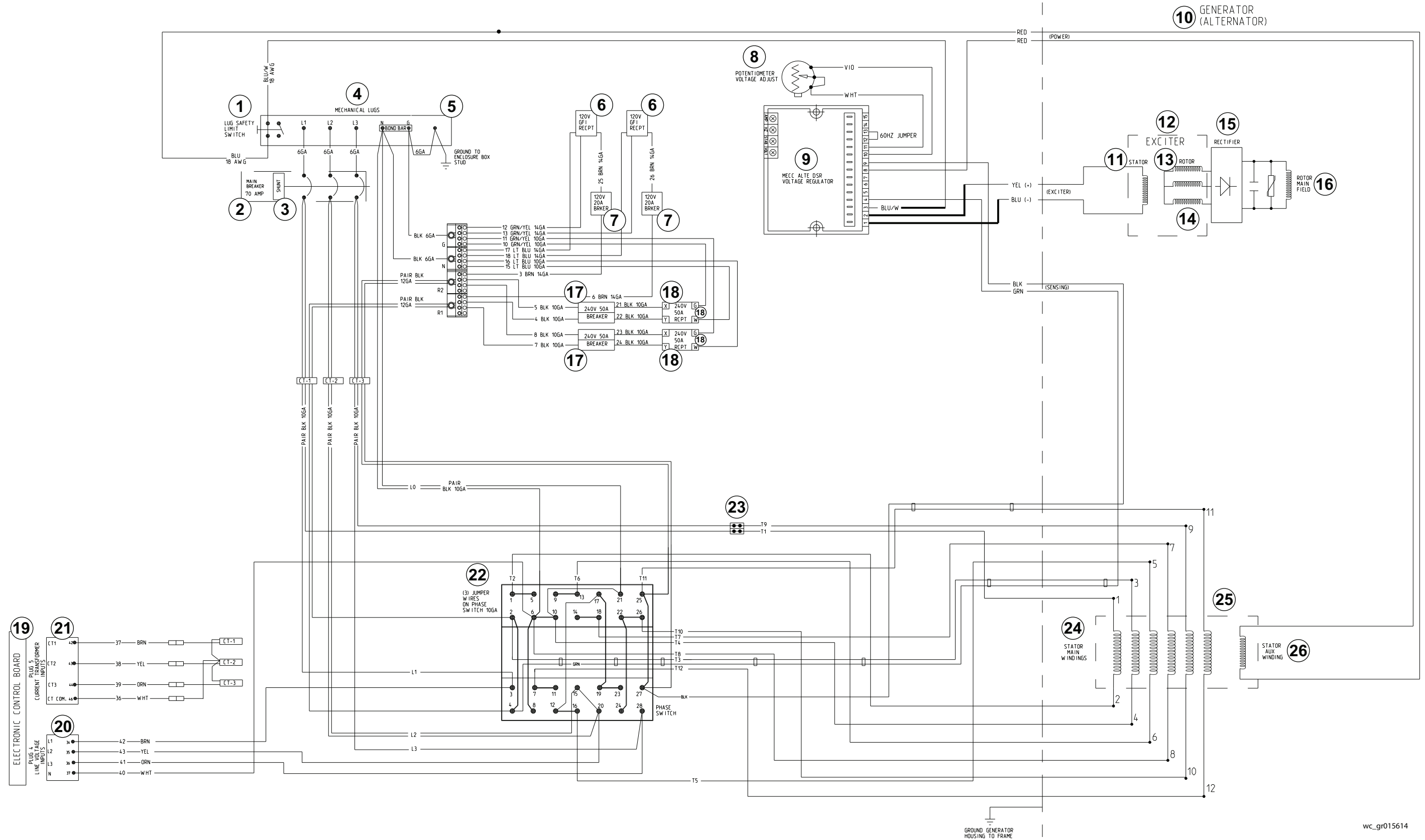

wc_gr015614

26.2 AC Schematic Components: G25 480V

Ref.	Description	Ref.	Description
1	Lug safety limit switch	14	Exciter rotor windings
2	Main breaker	15	Rectifier (diodes)
3	Shunt	16	Main rotor winding
4	Mechanical lugs	17	240V 50A breaker
5	Bus bar	18	240V 50A receptacle
6	120V GFI receptacle	19	Engine control module
7	120V 20A breaker	20	Plug 4—line voltage inputs
8	Voltage adjustment rheostat	21	Plug 5—current transformer inputs
9	Voltage regulator with 4A fuse	22	Voltage selector switch
10	Generator	23	Terminal block
11	Exciter stator winding	24	Main stator windings
12	Exciter	25	Stator
13	Rotor	26	Auxiliary stator winding

Wire Colors							
BLK	Black	RED	Red	WHT	White	ORG	Orange
GRN	Green	TAN	Tan	YEL	Yellow	BRN	Brown
BLU	Blue	VIO	Violet	GRY	Gray	PNK	Pink

26.3 AC Schematic: G25 600V

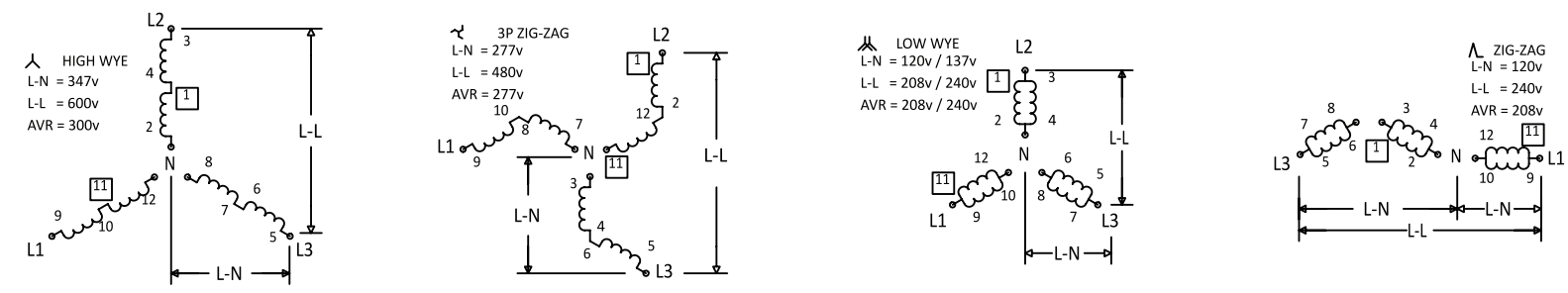
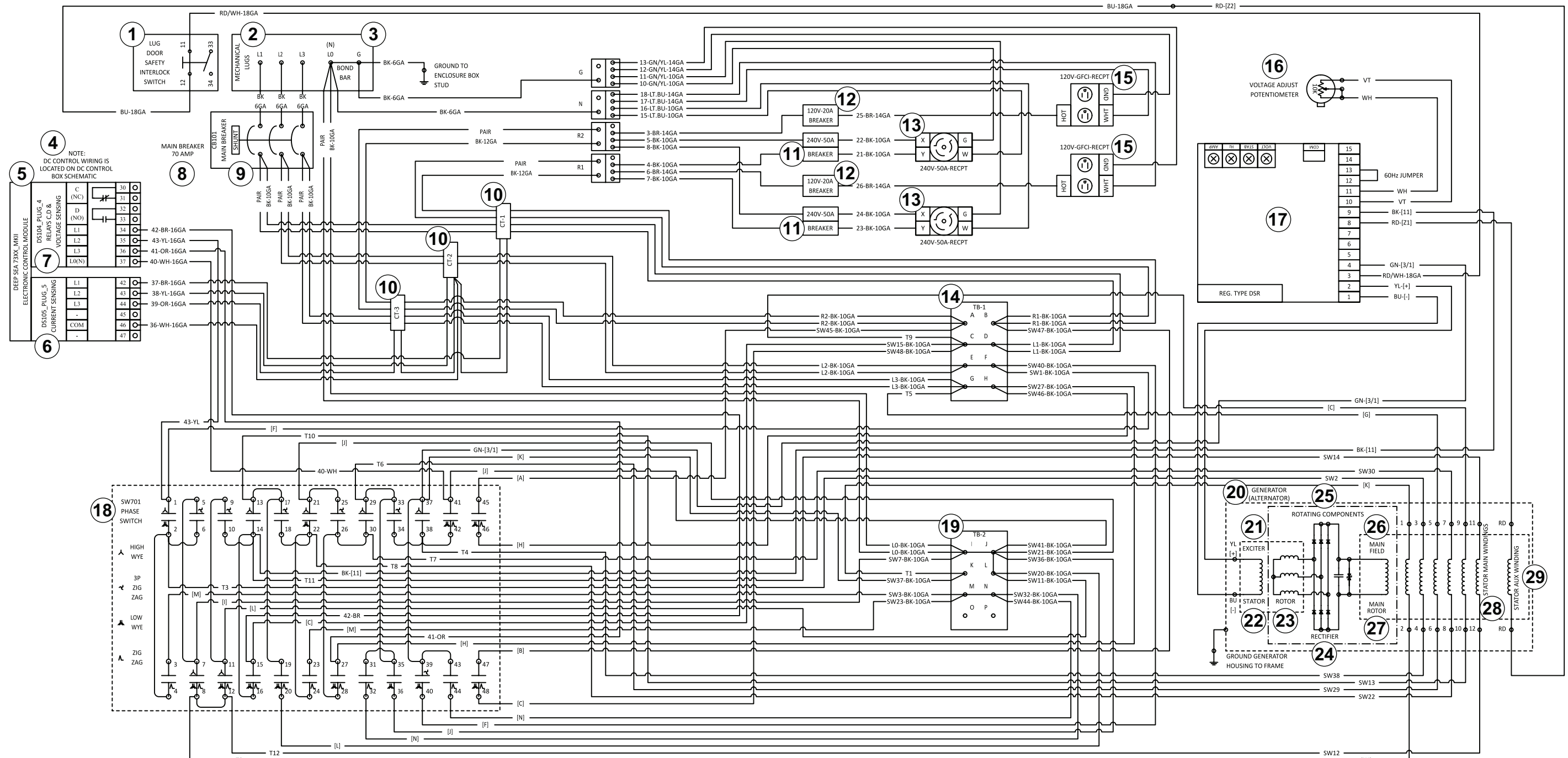

wc_gr015615

26.4 AC Schematic Components: G25 600V

Ref.	Description	Ref.	Description
1	Lug limit switch	16	Voltage adjustment rheostat
2	Mechanical lugs	17	Voltage regulator
3	Bus bar (bond bar)	18	Voltage selector switch
4	Generator controller	19	Terminal block (2)
5	Note: DC control wiring is located on the DC control box schematic	20	Generator
6	Plug 5 — current transformer inputs	21	Exciter
7	Plug 3 — line voltage inputs	22	Exciter stator winding
8	Main breaker	23	Exciter rotor windings
9	Shunt	24	Rectifier
10	Current transformers	25	Rotor
11	240V 50A breaker	26	Main field
12	120V 20A breaker	27	Main rotor winding
13	240V 50A receptacle	28	Main stator windings
14	Terminal block (1)	29	Auxiliary stator winding
15	120V GFCI receptacle	—	—

Wire Colors							
BK	Black	RD	Red	YL	Yellow	OR	Orange
GN	Green	TN	Tan	BR	Brown	PU	Purple
BU	Blue	VIO	Violet	CL	Clear	SH	Shield
PK	Pink	WH	White	GY	Gray	LB	Lt. Blue

26.5 AC Schematic: T4i, T4f

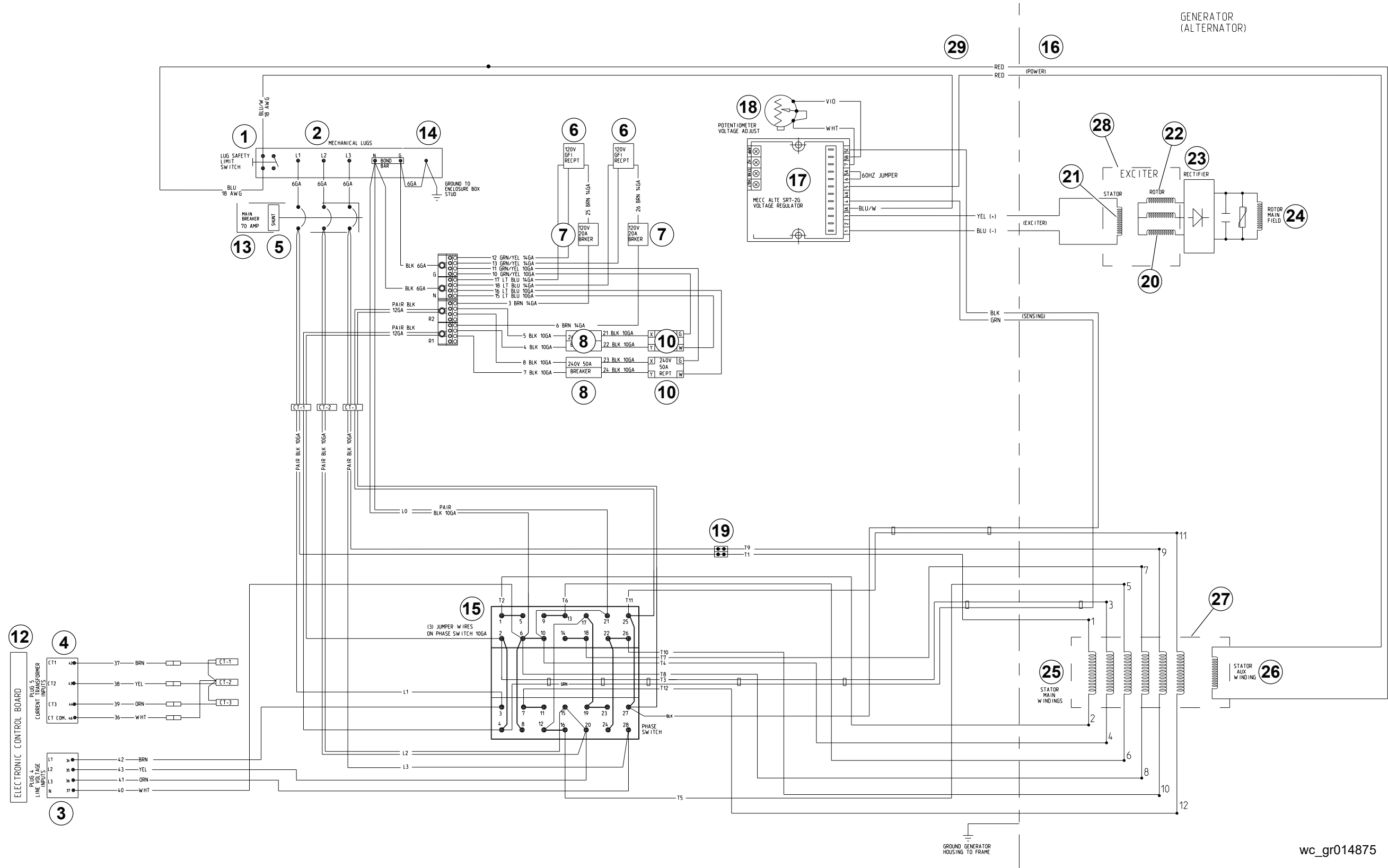

wc_gr014875

26.6 AC Schematic Components: T4i, T4f

Ref.	Description	Ref.	Description
1	Lug safety limit switch	16	Generator
2	Mechanical lugs	17	Voltage regulator with 4A fuse
3	Plug 4—line voltage inputs	18	Voltage adjustment rheostat
4	Plug 5—current transformer inputs	19	Terminal block
5	Shunt	20	Exciter rotor windings
6	120V GFI receptacle	21	Exciter stator winding
7	120V 20A breaker	22	Rotor
8	240V 50A breaker	23	Rectifier (diodes)
9	240V 20A breaker (optional)	24	Main rotor winding
10	240V 50A receptacle	25	Main stator windings
11	240V 20A receptacle (optional)	26	Auxiliary stator winding
12	Engine control module	27	Stator
13	Main breaker	28	Exciter
14	Bus bar	29	Machine
15	Voltage selector switch	—	—

Wire Colors							
BLK	Black	RED	Red	WHT	White	ORG	Orange
GRN	Green	TAN	Tan	YEL	Yellow	BRN	Brown
BLU	Blue	VIO	Violet	GRY	Gray	PNK	Pink

26.7 DC Schematic: T4i, Deep Sea

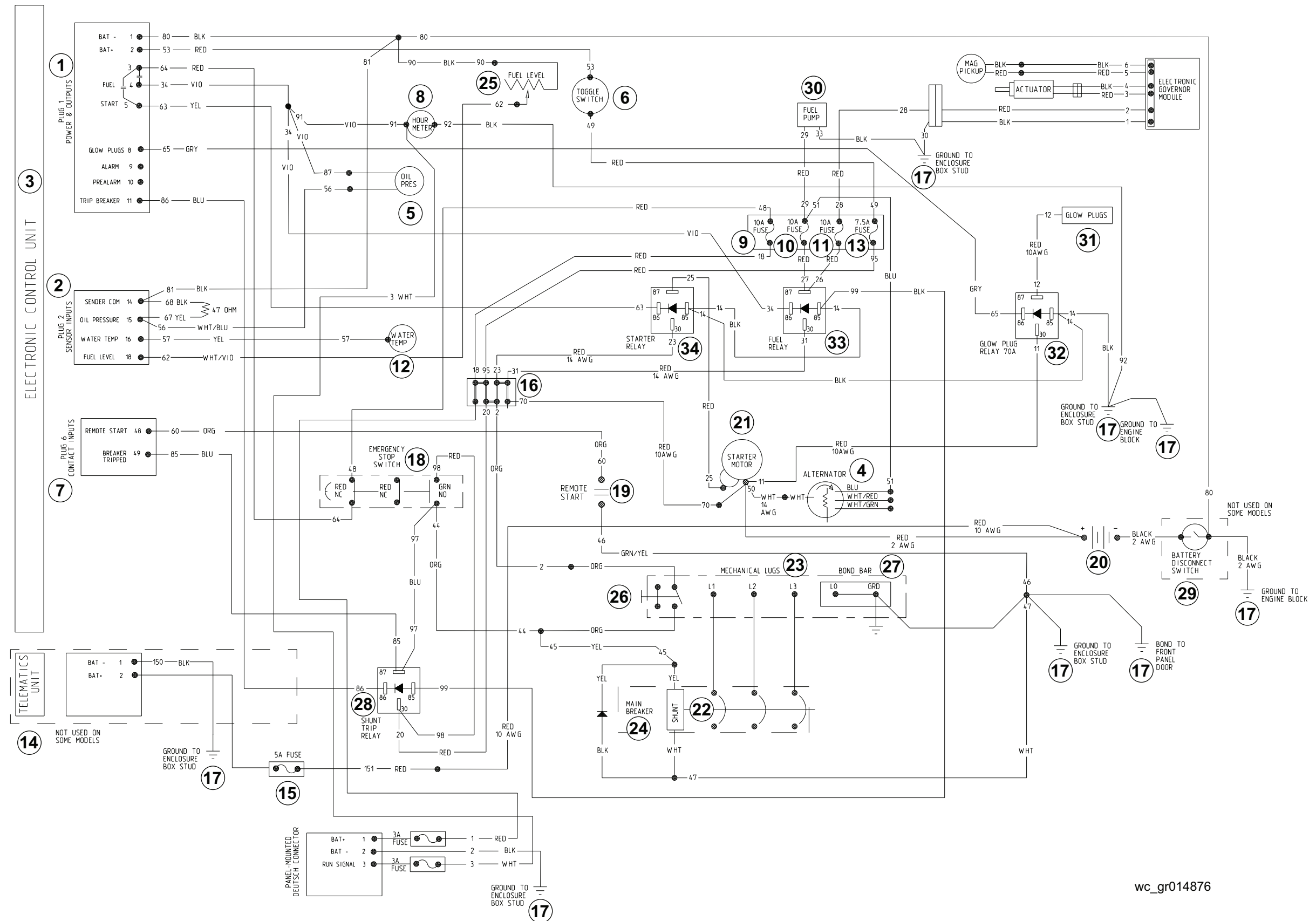

wc_gr014876

26.8 DC Schematic Components: T4i, Deep Sea

Ref.	Description	Ref.	Description
1	Plug 1—power and outputs	11	10A fuse
	Battery -	12	Water temperature
	Battery +	13	7.5A fuse
	Fuel	14	Telematics unit (if equipped)
	Start	15	5A fuse (if equipped)
	Glow plugs	16	Terminal strip
	Alarm	17	Ground
	Pre-alarm	18	Emergency stop switch
	Trip breaker	19	Remote start terminals
2	Plug 2—sensor inputs	20	Battery
	Sender com	21	Starter motor
	Oil pressure	22	Shunt
	Water temperature	23	Mechanical lugs
	Fuel level	24	Main circuit breaker
3	Electronic control unit (genset)	25	Fuel level sender
4	Alternator	26	Lug door interlock switch
5	Oil pressure	27	Bond bar
6	Toggle switch	28	Shunt trip relay
7	Plug 6—contact inputs	29	Battery disconnect (if equipped)
	Remote start	30	Fuel pump
	Breaker tripped	31	Glow plugs
8	Hour meter	32	Glow plug relay
9	10A fuse	33	Fuel pump relay
10	10A fuse	34	Starter relay

Wire Colors							
BLK	Black	RED	Red	WHT	White	ORG	Orange
GRN	Green	TAN	Tan	YEL	Yellow	BRN	Brown
BLU	Blue	VIO	Violet	GRY	Gray	PNK	Pink

26.9 DC Schematic: T4f

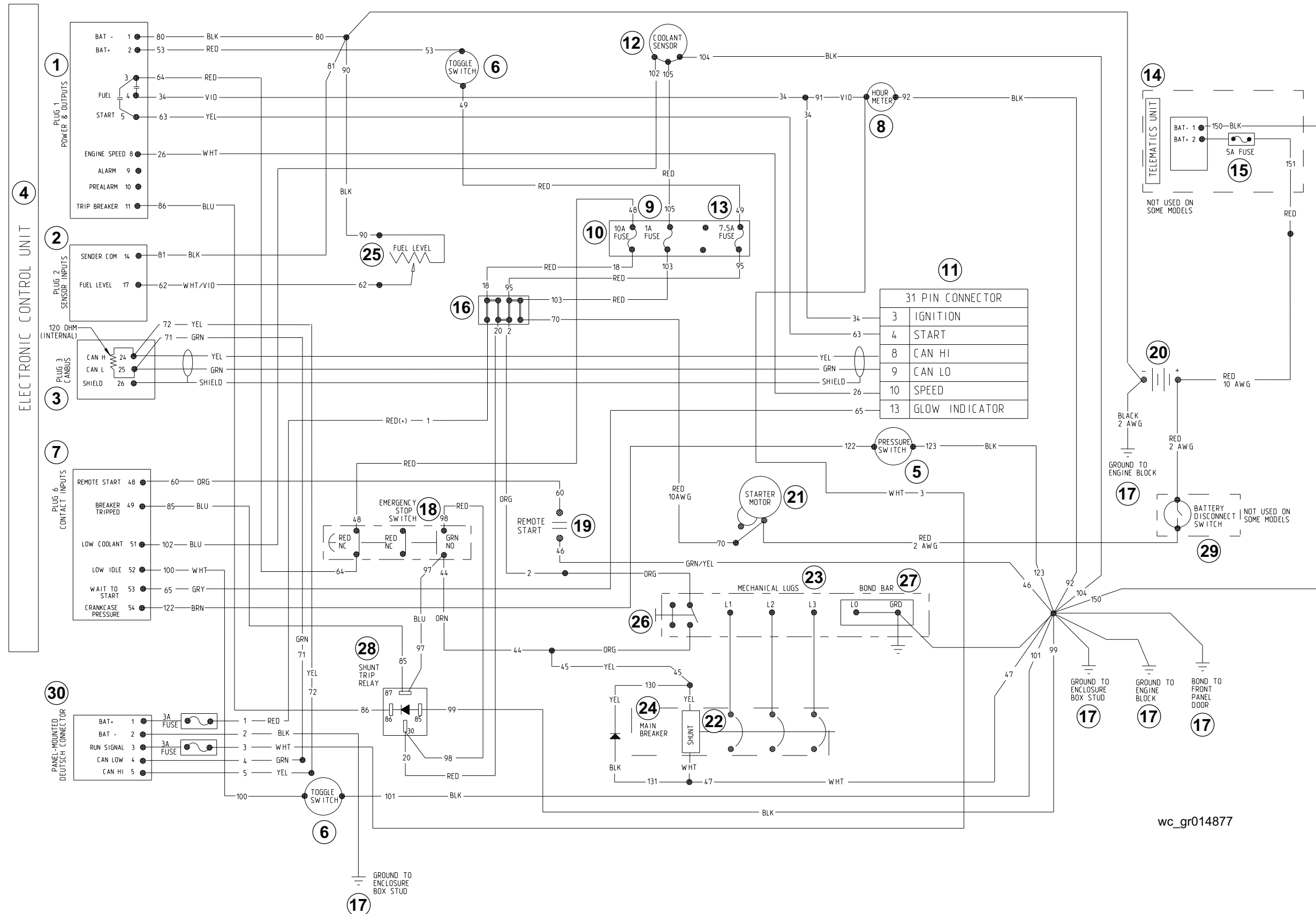

wc_gr014877

26.10 DC Schematic Components: T4f

Ref.	Description	Ref.	Description
1	Plug 1—power and outputs	9	1A fuse
	Battery -	10	10A fuse
	Battery +	11	Connector
	Fuel		Ignition
	Start		Start
	Engine speed		CAN hi
	Alarm		CAN lo
	Pre alarm		Speed
	Trip breaker		Glow indicator
2	Plug 2—sensor inputs	12	Coolant sensor
	Sender com	13	7.5A fuse
	Fuel level	14	Telematics unit (if equipped)
3	Electronic control unit (controller)	15	5A fuse (if equipped)
4	Plug 3—CAN bus	16	Terminal strip
	CAN hi	17	Ground
	CAN lo	18	Emergency stop switch
	Shield	19	Remote start terminals
5	Pressure switch	20	Battery
6	Toggle switch	21	Starter motor
7	Plug 6—contact inputs	22	Shunt
	Remote start	23	Mechanical lugs
	Breaker tripped	24	Main circuit breaker
	Low coolant	25	Fuel level sender
	Low idle	26	Lug door interlock switch
	Wait to start	27	Bond bar
	Crankcase pressure	28	Shunt trip relay
8	Hour meter	29	Battery disconnect (if equipped)

Wire Colors							
BLK	Black	RED	Red	WHT	White	ORG	Orange
GRN	Green	TAN	Tan	YEL	Yellow	BRN	Brown
BLU	Blue	VIO	Violet	GRY	Gray	PNK	Pink

Important: For spare parts information, please see your Wacker Neuson Dealer, or visit the Wacker Neuson website at <http://www.wackerneuson.com/>.

Wichtig! Informationen über Ersatzteile erhalten Sie von Ihrem Wacker Neuson Händler oder besuchen Sie die Wacker Neuson Website unter <http://www.wackerneuson.com/>.

Important : Pour des informations sur les pièces détachées, merci de consulter votre distributeur Wacker Neuson, ou de visiter le site Internet de Wacker Neuson sur <http://www.wackerneuson.com/>.

Importante : Para saber más sobre las piezas de repuesto, póngase en contacto con su distribuidor de Wacker Neuson o acceda al sitio web de Wacker Neuson en <http://www.wackerneuson.com/>.

Importante : Per informazioni sui pezzi di ricambio, contattare il rivenditore Wacker Neuson o visitare il sito di Wacker Neuson all'indirizzo www.wackerneuson.com.

Viktigt : För information om reservdelar, kontakta din Wacker Neuson-leverantör eller besök Wacker Neusons webbplats på <http://www.wackerneuson.com/>.

Tärkeää : Pyydä varaosatietoja Wacker Neusonin jälleenmyyjältä tai vieraile Wacker Neusonin web-sivustolla osoitteessa <http://www.wackerneuson.com/>

Viktig : For informasjon om reservedeler, vennligst kontakt din Wacker Neuson-forhandler, eller besøk Wacker Neusons nettside på <http://www.wackerneuson.com/>.

Viktigt : Hvis du ønsker oplysninger om reservedele, bedes du kontakte din Wacker Neuson forhandler eller besøg Wacker Neuson websiden på <http://www.wackerneuson.com/>.

Belangrijk! Neem contact op met uw Wacker Neuson dealer of bezoek de website van Wacker Neuson op <http://www.wackerneuson.com/> voor meer informatie over reserveonderdelen.

Importante : Para obter informações sobre as peças sobresselentes, consulte o seu fornecedor da Wacker Neuson ou acesse ao site Web da Wacker Neuson em http://www.wackerneuson.com

Ważne : W celu uzyskania informacji na temat części zamiennych skontaktuj się z przedstawicielem firmy Wacker Neuson lub skorzystaj z witryny internetowej <http://www.wackerneuson.com/>.

Důležitě upozornění! Pro informace o náhradních dílech, prosím, kontaktujte svého Wacker Neuson dealera, nebo navštivte webové stránky <http://www.wackerneuson.com/>.

FONTOS: A pótalkatrészekre vonatkozó információkért kérjük, forduljon Wacker Neuson kereskedőjéhez vagy látogasson el a Wacker Neuson weboldalára a következő címen: <http://www.wackerneuson.com/>.

Важно! Для ознакомления с информацией о запасных частях, пожалуйста, обратитесь к местному торговому представителю компании Wacker Neuson или посетите веб-сайт <http://www.wackerneuson.com/>.

Σημαντικό : Για πληροφορίες σχετικά με τα ανταλλακτικά, μιλήστε με τον αντιπρόσωπό σας της Wacker Neuson, ή επισκεφθείτε τον ιστότοπο <http://www.wackerneuson.com/>.

Važno : Za rezervne dijelove obratite se svom Wacker Neuson prodavaču ili posjetite mrežne stranice tvrtke Wacker Neuson: <http://www.wackerneuson.com/>.

Önemli : Yedek parça bilgileri için Wacker Neuson Bayinize bakın veya Wacker Neuson web sitesini ziyaret edin. <http://www.wackerneuson.com/>

重要 交換部品の情報については、ワッカーノイソンディーラーにお問い合わせ頂くか、ワッカーノイソンウェブサイト <http://www.wackerneuson.com/> をご覧ください。

重要 有关备件信息，请咨询您的威克诺森经销商或访问威克诺森网站：
<http://www.wackerneuson.com/>。

Important : Pentru informații referitoare la piesele de schimb, vă rugăm să vă adresați distribuitorului Wacker Neuson sau să vizitați site-ul web Wacker Neuson la adresa <http://www.wackerneuson.com/>.

Важно : За информация относно резервни части, моля, обърнете се към местния дилър на Wacker Neuson или посетете уебсайта на Wacker Neuson на адрес <http://www.wackerneuson.com/>.

Wacker Neuson Produktion GmbH & Co. KG, Preußenstraße 41, D-80809 München,
Tel.: +49-(0)89-3 54 02-0 Fax: +49 - (0)89-3 54 02-390

Wacker Neuson America Corporation, N92W15000 Anthony Ave., Menomonee Falls, WI. 53051
Tel.: (262) 255-0500 Fax: (262) 255-0550 Tel.: (800) 770-0957

Wacker Neuson Limited - Room 1701-03 & 1717-20, 17/F. Tower 1, Grand Century Place, 193 Prince Edward Road West, Mongkok, Kowloon, Hongkong. Tel: (852) 3605 5360, Fax: (852) 2758 0032

